



CRESCENDO

T29CF002

E0040

The T29CF002, "CRESCENDO" is an Ultra High End 29mm soft dome tweeter with a HEXADYM magnet system.

An optimally shaped dome and integrated wide surround manufactured by SEAS from SONOMEX ensure excellent performance and consistency.

A high efficiency HEXADYM magnet system (US Patent 6020805) based on 6 radially magnetized NdFeB magnet blocks provide efficient ventilation and damping of cavities behind the dome, surround and voice coil. Moderate magnetic stray fields represent no problems in AV installations.

A generously underhung voice coil with flexible lead-out wires, ensures low distortion even with low crossover frequencies.

A 6mm precision machined aluminum front plate with moderate horn loading ensures linear frequency response and reasonable efficiency.

The central part of the horn is made from chrome plated precision machined brass.

A substantial injection moulded rear chamber made from zinc eliminates unwanted chamber wall resonances and conducts heat away from the magnet system. The rear chamber and the front plate are Nextel painted to obtain a durable and attractive finish.

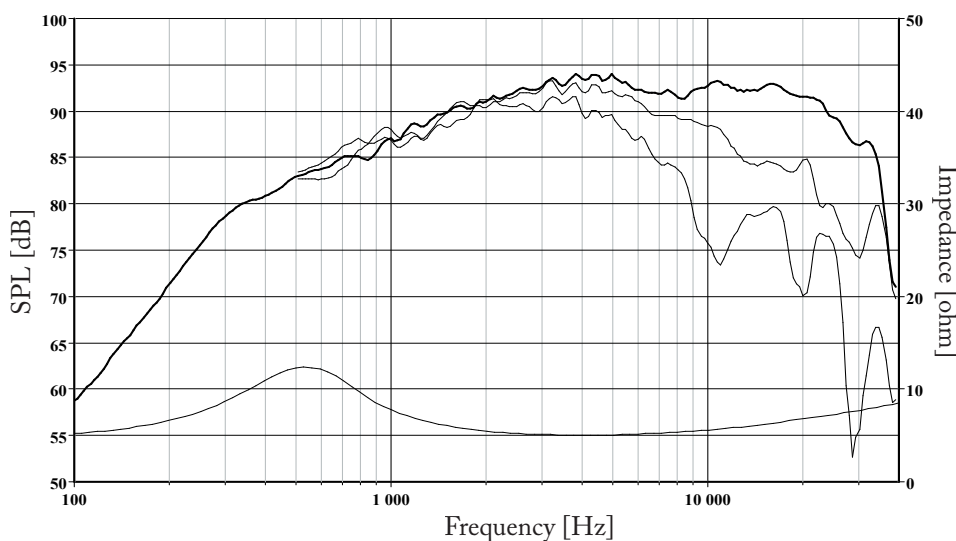

The frequency responses above show measured free field sound pressure in 0, 30, and 60 degrees, mounted in a 0.6m by 0.8m baffle. Input 2.83 V_{RMS}, microphone distance 0.5m, normalized to SPL 1m. The impedance is measured without baffle using a 2V sine signal.

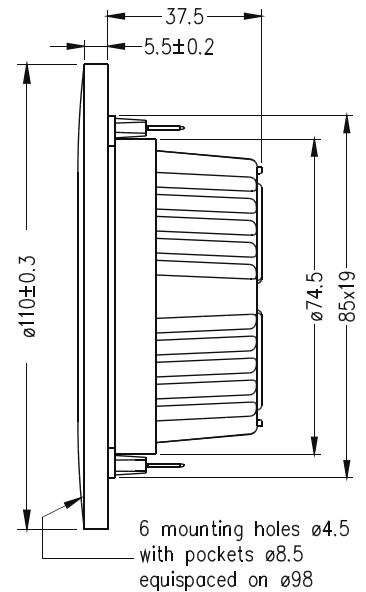

Nominal Impedance	6 Ohms	Voice Coil Resistance	4.7 Ohms
Recommended Frequency Range	2000 - 25000 Hz	Voice Coil Inductance	0.05 mH
Short Term Power Handling *	200 W	Force Factor	3.5 N/A
Long Term Power Handling *	90 W	Free Air Resonance	500 Hz
Characteristic Sensitivity (2.83V, 1m)	92.5 dB	Moving Mass	0.35 g
Voice Coil Diameter	26 mm	Effective Piston Area	8 cm ²
Voice Coil Height	1.5 mm	Magnetic Gap Flux Density	1.7 T
Air Gap Height	2.5 mm	Magnet Weight	53 g
Linear Coil Travel (p-p)	1 mm	Total Weight	0.66 kg