

27mm High Definition aluminum/magnesium alloy dome tweeter with a wide, soft polymer surround. The dome and surround materials give high consistency and excellent stability against variations in air humidity. The diaphragm is protected by a highly perforated hexagrid carrying an acoustic lens which tailors the high frequency roll off characteristic. The voice coil is wound on an aluminum voice coil former with adequate ventilating holes to eliminate noise from internal air flow. The voice coil is immersed in low viscosity magnetic fluid for high power handling capacity and simplified crossover design.

A shielded magnet system allows use in close proximity to video screens and TV sets. Using the screening can as a rear chamber with optimal acoustic damping allows 27TBFC/GTV to be used with moderately low crossover frequencies.

The chassis is precision moulded from glass fibre reinforced plastic, and its front design offers optimum radiation conditions.

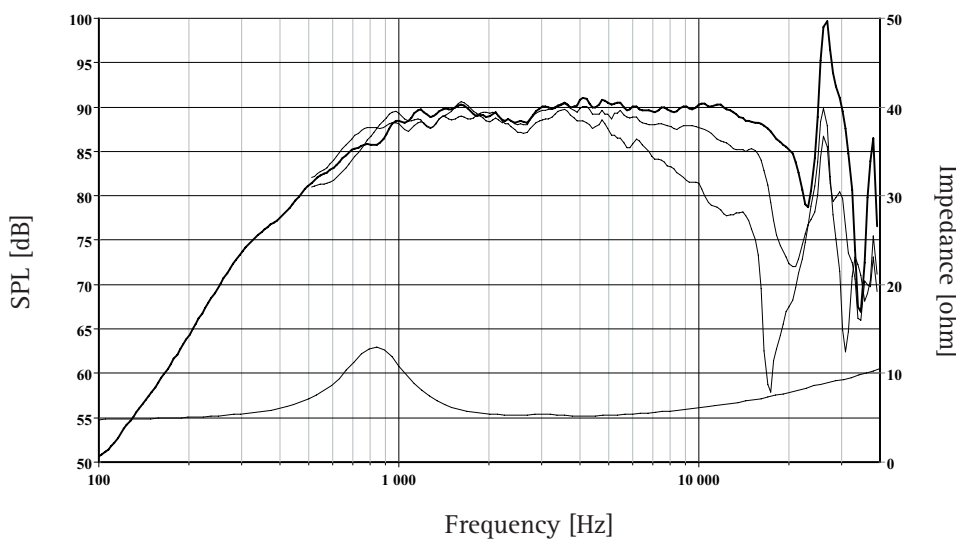

The frequency responses above show measured free field sound pressure in 0, 30, and 60 degrees, mounted in a 0.6m by 0.8m baffle. Input 2.83 Vrms, microphone distance 0.5m, normalized to SPL 1m. The impedance is measured without baffle using a 2V sine signal.

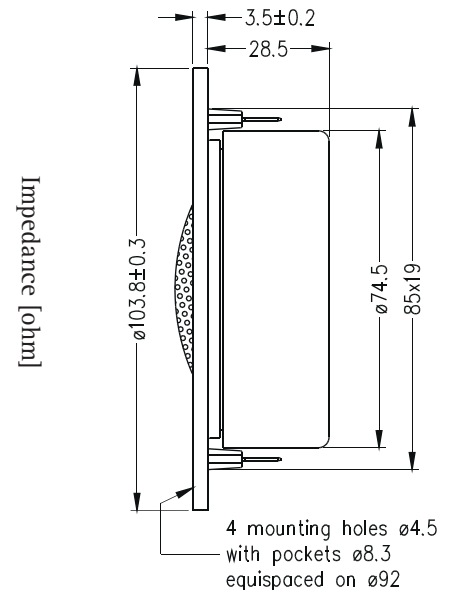

Nominal Impedance	6 Ohms	Voice Coil Resistance	4.8 Ohms
Recommended Frequency Range	2000 - 20000 Hz	Voice Coil Inductance	0.05 mH
Short Term Power Handling *	220 W	Force Factor	2.8 N/A
Long Term Power Handling *	90 W	Free Air Resonance	750 Hz
Characteristic Sensitivity (2.83V, 1m)	90.5 dB	Moving Mass	0.34 g
Voice Coil Diameter	26 mm	Effective Piston Area	7.5 cm ²
Voice Coil Height	1.5 mm	Magnetic Gap Flux Density	1.5 T
Air Gap Height	2.0 mm	Magnet Weight	0.40 kg
Linear Coil Travel (p-p)	0.5 mm	Total Weight	0.50 kg