

A classical manually coated paper cone and matching natural rubber surround produce a smooth response and reduce potential resonance problems.

A four layer voice coil provides a well behaved roll off characteristic.

A large magnet system gives good sensitivity and transient response.

Extremely stiff and stable injection moulded metal basket keeps the critical components in perfect alignment. Large windows in the basket both above and below the spider reduce sound reflexion, air flow noise and cavity resonance to a minimum.

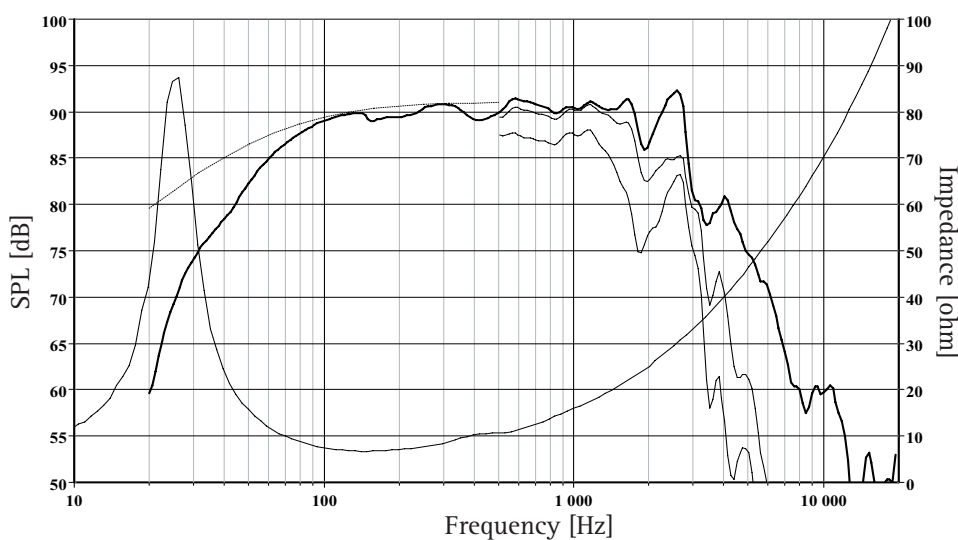

The frequency responses above show measured free field sound pressure in 0, 30, and 60 degrees angle using a 29.5L closed box. Input 2.83 V_{RMS}, microphone distance 0.5m, normalized to SPL 1m. The dotted line is a calculated response in infinite baffle based on the parameters given for this specific driver. The impedance is measured in free air without baffle using a 2V sine signal.

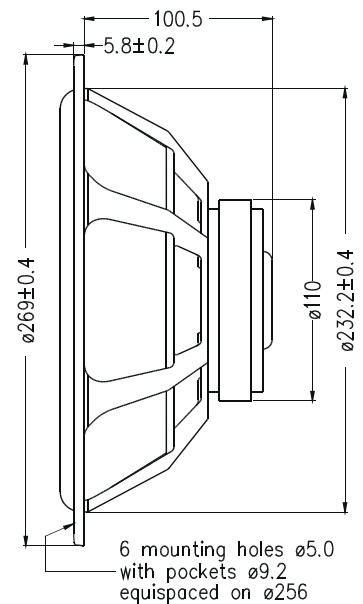

Nominal Impedance	8 Ohms	Voice Coil Resistance	6.1 Ohms
Recommended Frequency Range	30 - 1500 Hz	Voice Coil Inductance	3.08 mH
Short Term Power Handling *	300 W	Force Factor	11.6 N/A
Long Term Power Handling *	80 W	Free Air Resonance	25 Hz
Characteristic Sensitivity (2.83V, 1m)	91 dB	Moving Mass	38.5 g
Voice Coil Diameter	39 mm	Air Load Mass In IEC Baffle	3.8 g
Voice Coil Height	14 mm	Suspension Compliance	1.1 mm/N
Air Gap Height	6 mm	Suspension Mechanical Resistance	1.66 Ns/m
Linear Coil Travel (p-p)	8 mm	Effective Piston Area	350 cm ²
Maximum Coil Travel (p-p)	20 mm	VAS	164 Litres
Magnetic Gap Flux Density	0.9 T	QMS	3.99
Magnet Weight	0.64 kg	QES	0.30
Total Weight	2.17 kg	QTS	0.28