

- Home
- Newsletter
- Contact us
- How to buy
- OEM systems



WF110WA03 4½" neodymium mid/woofer, 8 ohm

WF110WA03 is the 8 ohm version of the WF110WA01, a mid/woofer designed for demanding bass and midrange applications. It works equally well for high-end hi-fi, high quality home theater systems, and top multimedia setups.

It is powered by a dual neodymium magnet structure that ensures good efficiency and optimal T/S parameters, and at the same time offers extremely good magnetical shielding.

The large 32mm voice coil and the special heat sink ensure high power handling - thermally and mechanically

The optimized paper cone ensures wide bandwidth and low distortion. Distortion is further reduced by efficient venting of chassis and voice coil.

WF110WA03 is an obvious choice for very compact 2-way speaker systems.



FEATURES

- Heat sink for increased heat transfer obtaining high long-term power handling
- Vented voice coil former for reduced distortion and compression
- Vented chassis for lower air flow speed reducing audible distortion
- Voice coil wound with Copper Clad Aluminium Wire for higher efficiency and better dynamics
- Heavy-duty black fiber glass voice coil bobbin to increase power handling and reduce mechanical losses resulting in better dynamic performance and low-level details
- Large motor system with 1¼" voice coil diameter and dual neodymium magnet for better control and efficiency
- Dual neodymium magnet structure for almost ideal magnetical shielding
- Long linear stroke motor for reduced distortion at high levels
- Linear suspension with specially designed CONEX damper (spider) for long durability under extreme operating conditions
- Gold plated terminals to prevent oxidation for long-term reliable connection

FREQUENCY RESPONSE

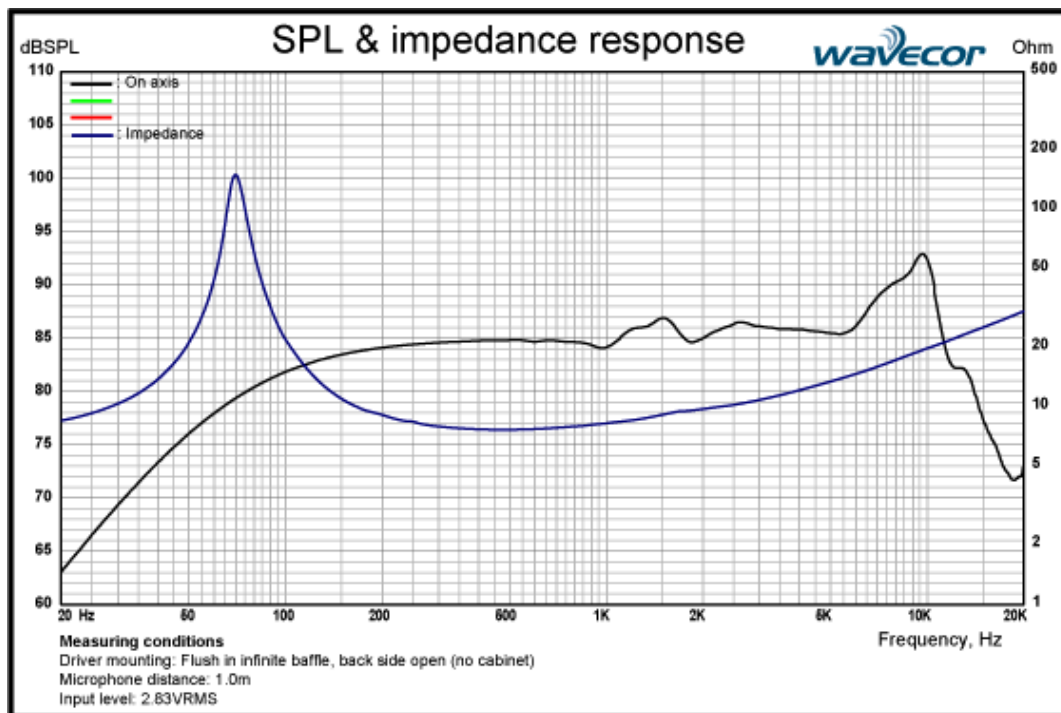

NOMINAL SPECIFICATIONS

Nominal size	4½ [inch.]
Nominal impedance	8 [ohm]
Recommended upper frequency limit	4 [kHz]
Recommended cabinet volume	2-4 [lit.]
Sensitivity, 2.83V/1m, (average 500-4,000Hz)	85.5 [dB]
Voice coil diameter	32.5 [mm]
Voice coil height	12 [mm]
Air gap height	4.0 [mm]
Voice coil resistance, R_{DC}	6.3 [ohm]
Voice coil inductance	0.20 [mH]
Magnet weight (dual neodymium)	102 [g]
Effective radiating area, S_d	55 [sq.cm]
Power handling, continuous, IEC 268-5	50 [W]
Resonance freq., F_s	78 [Hz]
Moving mass, incl. air, free air	6.0 [g]
Force factor, $B\ell$	5.9 [Tm]
Mechanical Q, Q_m	8.5 -
Electrical Q, Q_e	0.54 -
Total Q, Q_t	0.51 -
Suspension compliance, C_{ms}	0.70 [mm/N]
Equiv.. air volume, V_{as}	3.0 [lit.]
Total unit net weight	0.59 [kg]

Specification are before burn-in

OUTLINE DRAWING AND DIMENSIONS (mm)

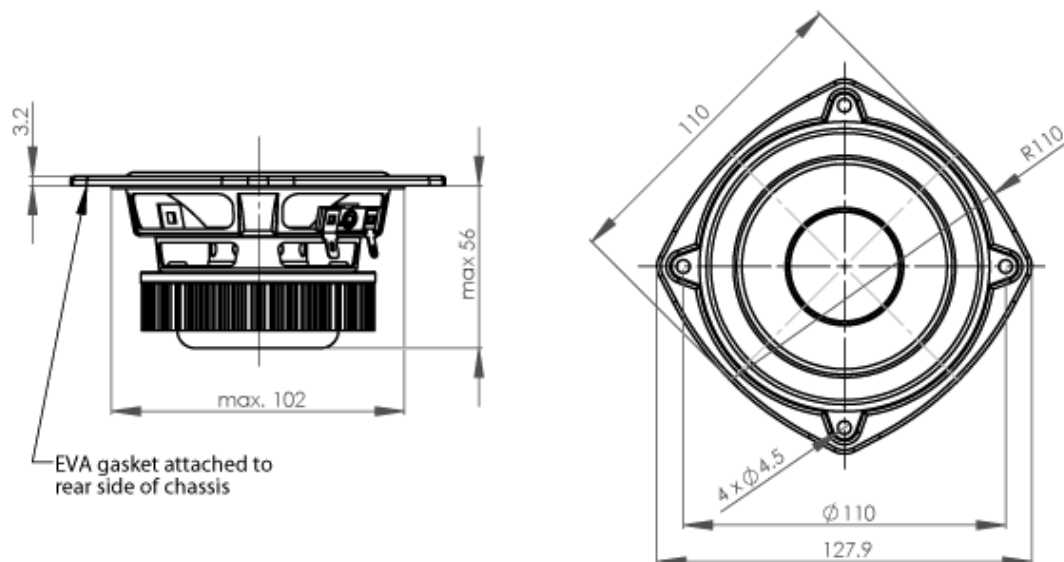

PACKAGING INFORMATION

Part no. WF110WA03-01	Individual packaging (one piece per box)
Part no. WF110WA03-02	Bulk packaging

Specifications are subject to change without any further notice.
 Copyright © 2006-2008 by Wavecor Ltd., Guangzhou, China. All rights reserved.