



BASS GUITAR AMPLIFIER MANUAL



TH *silver line*
CROSS



DESIGNED BY MUSICIANS FOR MUSICIANS

1

INTRODUCTION

TH-CROSS head type bass amplifier with both tube and transistor preamps and double power stage, working in BIAMP, STEREO or MONO modes. The switchable mode enables wide range of speaker cabinets to connect varying in impedance from 2 ohm to 16 ohm and handling power from 200W up to 750W. The amplifier uses a very efficient and at the same time easy to operate BOX ELECTRONICS' own unique **MLO-system** equalization control for fast and accurate sound tailoring. Unique **optical limiter** is built in for fast and noiseless operation. For those who prefer an independent tone control for each channel there is a possibility to "cross" the amplifier with an additional preamp. Connecting an external preamp creates a configuration of 2 selectable independent channels. The use of additional preamp brings a wide range of new sound creation opportunities: 2 identical panels with separate input stage control, tone, limiter and volume. A musician can set preferred tone shape, input sensitivity, tube saturation, volume and compression for each channel independently and switch between the channels while playing. Also an external sound effect can be connected to each of the channels. To create a stereo system a specially designed Taurus TX-CROSS dedicated preamp is used.

2

MLO-system Middle-range Level Optimization

*In TAURUS amplifiers designed by Box Electronics unique **MLO-system** equalization control has been applied to achieve easy and intuitional sound tailoring through only two Bass and Treble knobs. This type of sound correction makes it easy and fast to find the right tone colour. Characteristics of the tone settings are designed to meet the parameters of the instruments both technically and musically. In regular solutions one can practically use only 50% of the bass and treble correction range. The deeper correction usually results with loss of sound control. To make the best use of the 2 point correction it has been automatically coupled with midrange control. This solution provides optimal sound control especially in the adjacent mid and low frequencies and allows to use the whole range of the potentiometers for full spectrum of sound shape. Additionally the **MLO-system** results in same level volume output no matter how the low frequency control knob is positioned (no need for tricky correction of both bass and volume to keep the same loudness level). This lets the musician concentrate on the precise sound colour quality control only without any "too many knobs to operate" confusion.*

3

MAIN FEATURES

- Power output: 750W RMS
- Power Amps mode:
 - Mono: 750W/4ohm, 700W/6ohm, 600W/8ohm, 400W/16ohm
 - Biamp/Stereo: 2x375W/2ohm, 2x300W/4ohm, 2x250W/6ohm, 2x200W/8ohm
- **BALANCE** control between the power amps
- **2 PREAMPS** to choose from or mix together one with tube circuit
- Preamp configuration: 1 internal channel + 1 external channel used to connect a separate preamp channels selected by foot switch
- ACTIVE & PASSIVE input
- **GAIN** control with overload LED. Operating with Gain and Input Mix player can obtain sound very close to acoustic bass or fretless bass guitar. The area around knobs marked by a break-off line indicates the region where the level of compression and distortion allows achieving the desired effect.
- **PEAK** preamp overload indicator
- TONE CONTROLS:
 - **BASS** and **TREBLE** equalization with "**MLO-system**"
 - **PARAMETRIC EQUALIZER** for precise control of middle-range (120Hz...4kHz)
 - **PRESENCE** button - increases transparency of sound
 - **PUNCH** button - increases sonic accuracy
 - **DBS** (Dynamic Bass System) - increases dynamics and selectivity of bass sound
- **Studio quality optocoupler COMPRESSOR/LIMITER** with level control and ON/OFF button
- **VOLUME** control
- **MUTE** button
- EFFECT LOOPS:
 - **AUX** for serial and parallel configuration
 - **CROSS LOOP** parallel for external preamp with foot switch selectable internal and external channels
- **FOOT SWITCH** input (switches the additional preamp connected to AUX-2)
- **STEREO MODE input** for dedicated TAURUS TX-CROSS preamp
- Outputs: > XLR balanced LINE output with level control, speaker cabinet simulation, PRE/POST switch and GROUND LIFT circuit switch > PREAMP OUT > TUNER > PHONES
- Muted on/off switch
- Protections: Short circuit, thermal overload, power overload, speaker protection
- **CLIP** power amp indicator
- Forced cooling system with electronic efficiency control
- Dimensions: 19" (2 Rackspace) / (H x W x D) 88 x 483 x 370mm
- Weight: 11kg

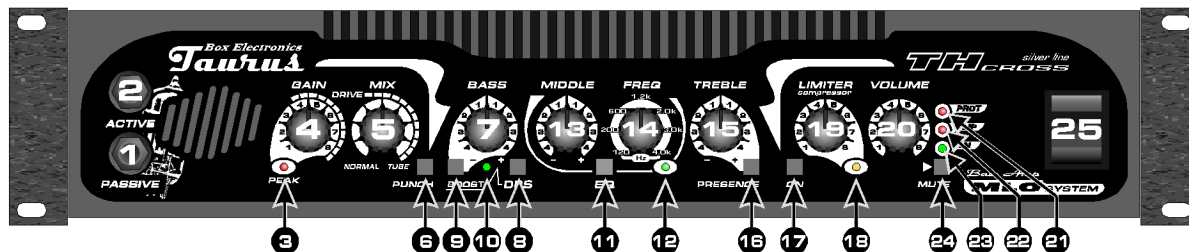

- [1] - Passive bass instrument INPUT [JACK 6.3mm]
- [2] - Active bass instrument INPUT [JACK 6.3mm]
- [3] - PEAK indicator in preamp section
- [4] - GAIN control
- [5] - INPUT MIX - fluent signal adjustment of the input between 2 sections of the amplifier - tube and transistor
- [6] - PUNCH button - increases sonic expression
- [7] - BASS CONTROL with MLO-system
- [8] - DBS (Dynamic Bass System) - increases dynamics and selectivity of bass sound
- [9] - DBS BOOST
- [10] - DBS ON indicator
- [11] - PARAMETRIC EQ on/off switch
- [12] - PARAMETRIC EQ indicator
- [13] - PARAMETRIC EQ level control
- [14] - PARAMETRIC EQ frequency adjustment (120Hz...4kHz)
- [15] - TREBLE CONTROL with MLO-system
- [16] - PRESENCE button - increases transparency of sound
- [17] - LIMITER-COMPRESSOR on/off switch
- [18] - LIMITER indicator
- [19] - COMPRESSION level adjustment
- [20] - VOLUME control
- [21] - PROTECTION indicator
- [22] - Power amplifier CLIP indicator
- [23] - ON/MUTE indicator
- [24] - MUTE on/off switch
- [25] - POWER on/off switch

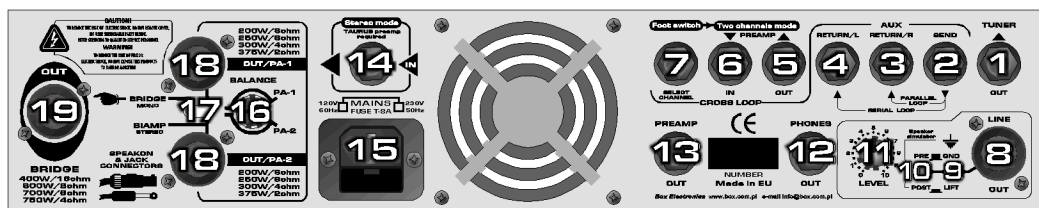

- [1] - TUNER OUTPUT [JACK 6.3mm]
- [2] - AUX SEND OUTPUT [JACK 6.3mm]
- [3] - AUX RETURN INPUT [JACK 6.3mm] - PARALLEL LOOP
- [4] - AUX RETURN INPUT [JACK 6.3mm] - SERIAL LOOP
- [5] - CROSS LOOP OUTPUT [JACK 6.3mm] - for external preamp
- [6] - CROSS LOOP INPUT [JACK 6.3mm] - for external preamp
- [7] - FOOT SWITCH INPUT (switches the external preamp connected to Cross Loop)
- [8] - LINE OUTPUT [XLR]
- [9] - LINE OUTPUT GROUND LIFT switch
- [10] - LINE OUTPUT PRE/POST EQ switch
- [11] - LINE OUTPUT LEVEL control
- [12] - HEADPHONE OUTPUT [JACK 6.3mm]
- [13] - PREAMPLIFIER OUTPUT [JACK 6.3mm]
- [14] - INPUT for external Taurus preamp in stereo mode [JACK 6.3mm]
- [15] - IEC POWER INPUT SOCKET with AC fuse - T8A/230V , T10A/120V →
- [16] - BALANCE control between the power amps
- [17] - MODE POWER AMPS MODE switch [BIAMP-stereo/BRIDGE-mono]
- [18] - LOUDSPEAKER OUTPUTS for BIAMP-stereo mode [SPEAKON+JACK 6.3mm]
- [19] - LOUDSPEAKER OUTPUT for BRIDGE-mono mode [SPEAKON+JACK 6.3mm]

IMPORTANT NOTE:

Always use slow blow or time delay type fuses.
Do not use fast blow fuses.

- A** Before you turn on the amplifier, set the **BALANCE** controller [16] on the back panel of the amplifier in the middle position and then select appropriate power amp mode by setting switch [17] as required (see the configuration schematic in point 9). Two options are available: **BRIDGE-MONO** or **BIAMP-STEREO**. Then connect loudspeakers to appropriate outputs in the amplifier. You can connect loudspeakers using cables with **SPEAKON** or **JACK 6.3mm** plugs.
Mind the proper power and impedance of loudspeakers while you connect them.
If you have selected **BRIDGE-MONO** mode, connect loudspeaker or loudspeakers set to the **BRIDGE** socket [19]. If you have selected **BIAMP-STEREO** mode, connect one loudspeakers set to the **OUT PA-1** socket and other loudspeakers set to the **OUT PA-2** socket. You can use only one loudspeaker in **BIAMP-STEREO** mode connecting loudspeaker to the **OUT PA-1** or **OUT PA-2** socket.
- B** Set controllers and switches on the front panel in following positions:
- tone color controllers - **BASS**, **MIDDLE**, **FREQ** and **TREBLE** - in position "0",
 - remaining controllers in maximum left position,
 - all mode switches in turned off position.
- C** Connect your bass guitar to appropriate input in the amplifier (**ACTIVE** or **PASSIVE**), and then switch on the power.

Basic elements that make up the character of desired sound are tone color and its dynamism. Section composed of controllers **BASS**, **TREBLE**, **PARAMETRIC EQUALIZER** as well as switches **PUNCH**, **DBS** and **PRESENCE** is responsible for tone color. In turn, controllers **GAIN** and **COMPRESSOR/LIMITER**, are responsible for tone dynamics. Controller **MIX** changes both the tone color and dynamics. Before setting about adjusting ones own tone, one ought to set controllers in positions determined in point 6B. Firstly set tone color using only **BASS** and **TREBLE** controllers and **DBS** and **PRESENCE** switches. In case when the adjustment is insufficient, use **PARAMETRIC EQUALIZER**, **MIX** adjustment or **PUNCH** switch.

► FIRST USING TIPS

- A** Set **VOLUME** controller in optimum and then set appropriate input sensitivity by using **GAIN** controller. **GAIN** controller should be set in a way that ensures to control the amplifier on required level. It is necessary to remember not to allow to overload the preamplifier while hard hitting the strings. The overload is indicated with **PEAK** indicator [3].
- B** If you have 2 loudspeaker sets connected to the amplifier in **BIAMP** system, then set **BALANCE** controller [16] on the back panel in the position that will enable to obtain relatively balanced sound level between the loudspeakers. In **STEREO** and **MONO** mode the controller should be set in the middle of the scale of **BALANCE** controller.
- C** Set the **MIX** controller in **NORMAL** position and go to tone control. Begin with adjusting **BASS** and **TREBLE** controllers. If you need stronger bass tone saturation switch on **DBS-ON** button, if you need much more bass tone, additionally switch on **BOOST** button. If you need to brighten the tone color, switch on **PRESENCE** button.
- D** **PARAMETRIC EQUALIZER** and **MIX** adjustment with **PUNCH** switch give more advanced tone control.
- Using equalizer you can precisely correct mid tones color. **PARAMETRIC EQUALIZER** is composed of 2 controllers - **MIDDLE** and **FREQUENCY**. One of controllers [**MIDDLE**] is designed for mid tones level adjustment. Using of the other controller [**FREQUENCY**] you can select appropriate mid tones range that you want to adjust. **MIDDLE** controller decides whether we want to amplify or cut out selected tone range. Setting **MIDDLE** controller in position "0" does not make any changes. Available adjustment range is set between 120Hz and 4kHz. You can switch on and off the equalizer using **ON** [11] button.
 - By using **MIX** controller you can change the tone character balancing between transistor and tube pre-amplifiers. Setting **MIX** potentiometer in **NORMAL** position assures dynamic and hard tone provided by transistor pre-amplifier. In **TUBE** position you will obtain characteristic warm and soft tone provided by lamp pre-amplifier. Depending on the **MIX** controller status the tone color of both channels is mixed together. If you want to get a little bit dirty and compressed sound that is provided by lamp pre-amplifier, you need to boost input sensitivity with use of **GAIN** controller. On the **GAIN** and **MIX** controllers' scale, the range you can obtain **DRIVE** typical for the tube, is marked with gapped line. If you want to set hard **DRIVE**, just increase **GAIN** controller while setting **MIX** position on right. It will sounds better if you turn off the **TWEETER**.
 - If you desire your bass tone be more exposed you can add more expression by using **PUNCH** switch [6] that causes the amplification the tone color in the range of "hard middle".
- E** If you have already set appropriate tone color of the instrument you can go to tone dynamism adjustment. High quality optical **COMPRESSOR/LIMITER** is at you disposal. The handling is very simple, you only need to switch on the **ON** [17] button and then while playing you set the level controller [19] in the appropriate position. Limiter action is indicated by **LED** [18].
- If you want to use limiter in order to secure against changing the power grade while loud and dynamic play, set the controller [19] in such position not to let the **CLIP LED** [22] to light on that indicates exceeding of maximum power amplifier level.
 - If you want to obtain appropriate tone compression, you should to increase limiter sensitivity by adjusting the controller [19] to the right. The sound compression can be enlarged even more by increasing sensitivity in the input of pre-amplifier with use of **GAIN** controller.
- F** In order to enrich the instrument sound you can use additional sound effects, external effects' loop **AUX** is designed for that, see point 10. Remember that you can build up your system of another pre-amplifier **TAURUS TX-CROSS** by connecting it to the auxiliary loop **CROSS LOOP**, see points 11 and 12.

The amplifier is equipped with automatic power amplifier protecting systems. Activating the protection is noticed with PROT indicator located on the front panel of the amplifier. In case when the indicator is on permanently, then the loudspeakers are going to be disconnected. Inactivating of protection systems should be performed by turning off and on the amplifier. If the amplifier does not return to normal action, it means that the anti-overload or anti-short circuit system has been activated. In such case it is necessary to check loudspeakers impedance (it may be too low) and amplifier-loudspeakers connection (there may be short circuit). If the PROT indicator is still on, check the amplifier temperature (it may be too high). In this case just wait few minutes to amplifier cooling.

- It is necessary to take appropriate loudspeakers' parameters selection into consideration. Do not connect loudspeakers of too low rating power or too low impedance value to the amplifier's outputs, it can cause loudspeakers damage.
- In order to protect the loudspeakers avoid power amplifier overload. Power amplifier overload is indicated with CLIP LED located in the front panel of the amplifier. CLIP LED can flash under influence of strong sound impulses, however it is not recommended to set the amplifier in a way that the CLIP LED flashes very often.
- The amplifier should be place in a spot that enables free air circulation for the cooling system to work properly. While assembling the amplifier under RACK type systems it is not admissible to overcast air inflow to the fan located on the back panel of the amplifier.
- It is recommended to use plugs with grounding.
- The amplifier should be used away from a heat sources.
- Protect the amplifier against moisture.
- A perfusion of the amplifier may cause damage or electric shock.
- Never try to repair the amplifier personally.
- Use fuses of parameters recommended by the producer only.

9 CONFIGURATION OF AMPLIFIER AND SPEAKERS CONNECTION

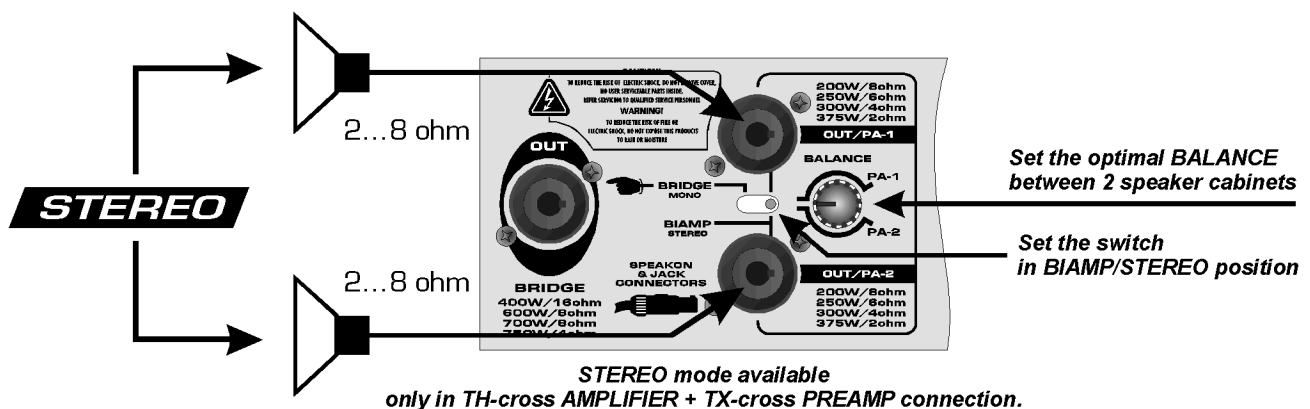
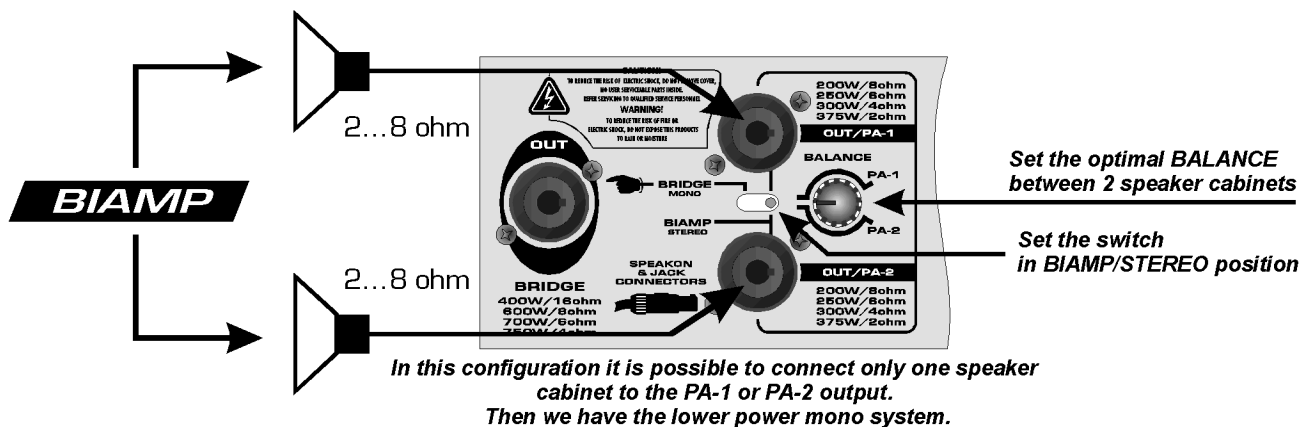
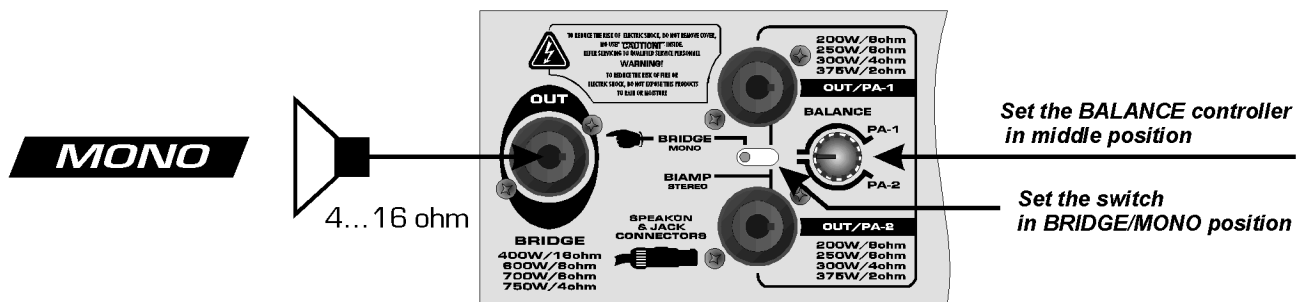

Connection to PARALLEL MONO LOOP

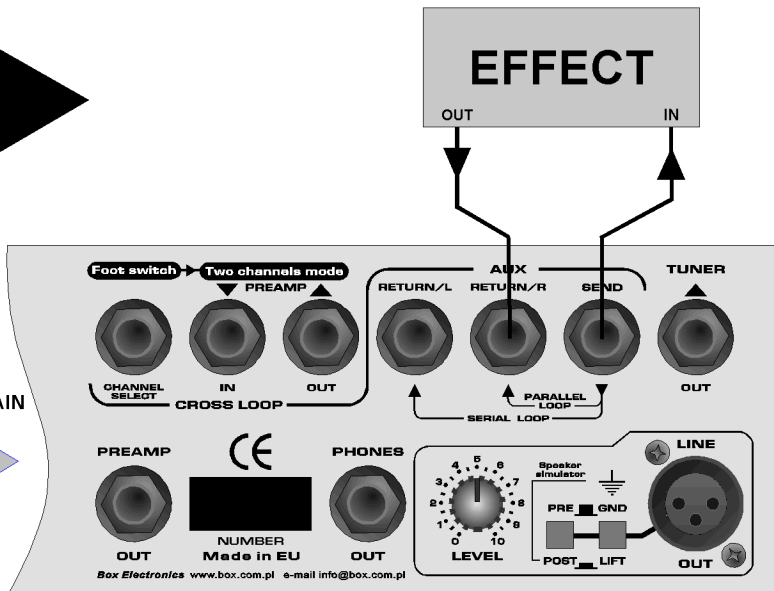
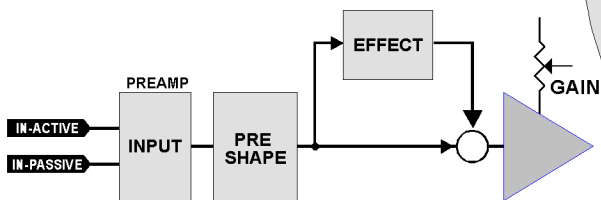

Connection to SERIAL MONO LOOP

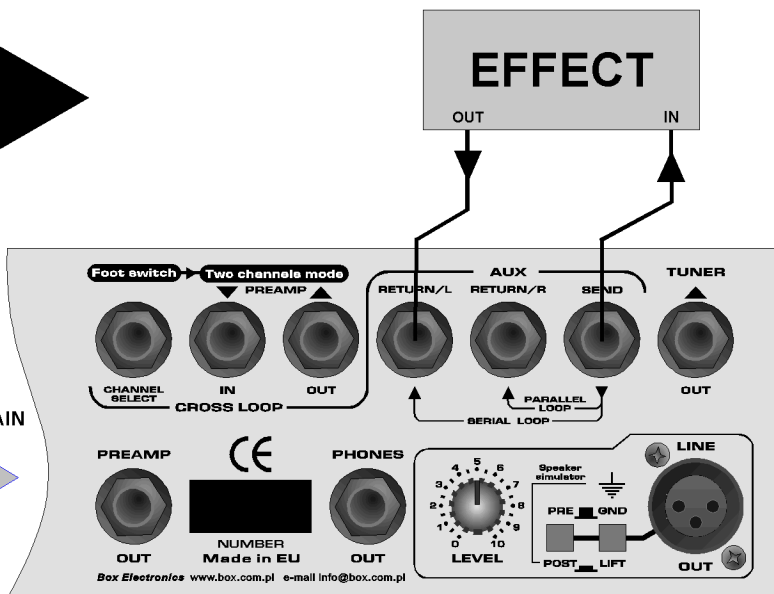
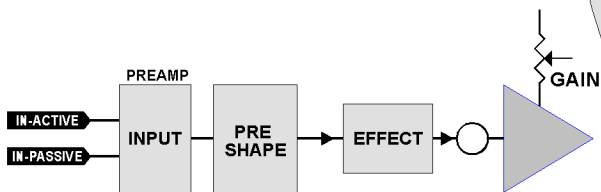

Connection to SERIAL STEREO LOOP

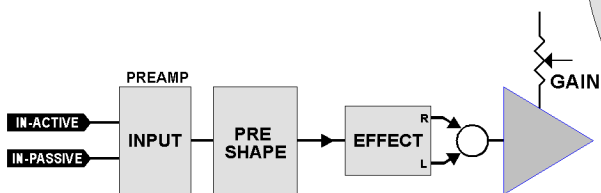

SELECT CHANNEL

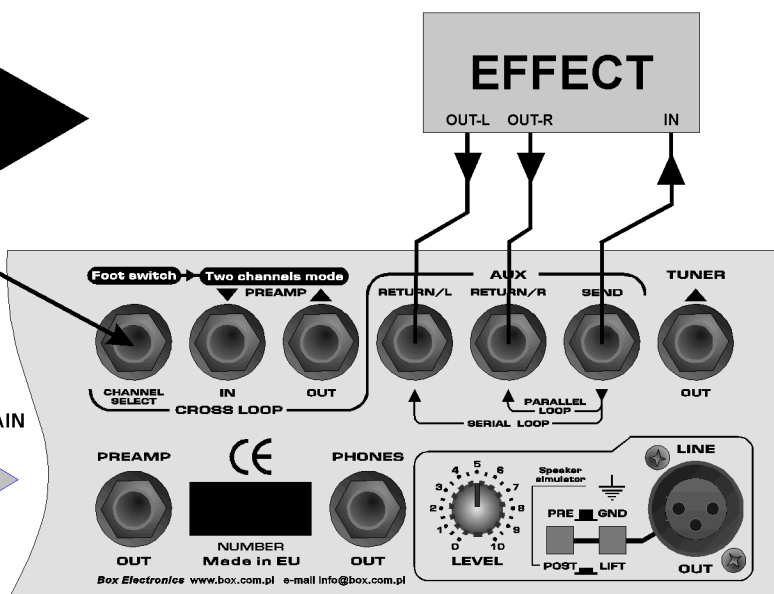

CAUTION: If any switch isn't connected to the SELECT CHANNEL connector, then the AUX-2 loop is still active. It is working together with the preamp, so it is possible to use it similarly to AUX-1.

A WORK WITH PREAMP

11 TH-cross AMPLIFIER TO TX-cross PREAMP CONNECTION

- Connection in 2 channel configuration
- - - - - Connection in stereo configuration

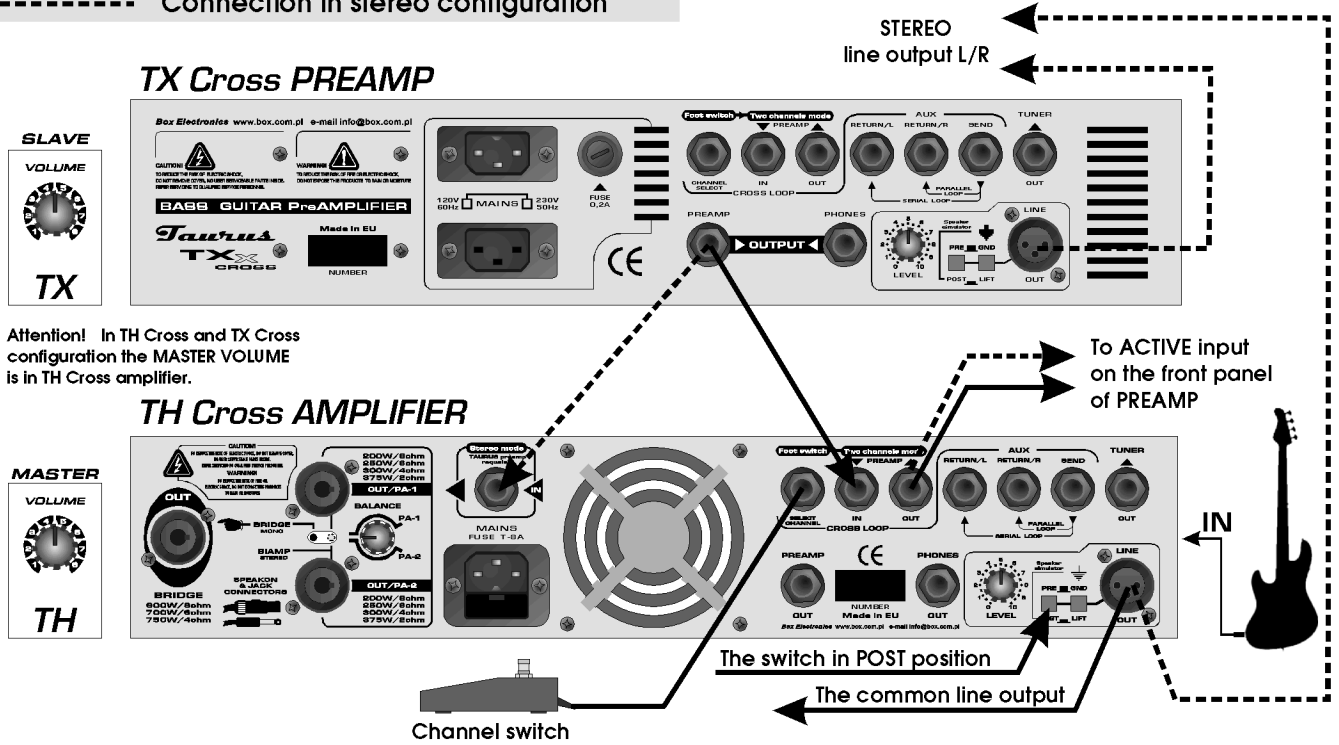

12 AMP+PREAMP TO SOUND EFFECT CONNECTION /STEREO MODE/

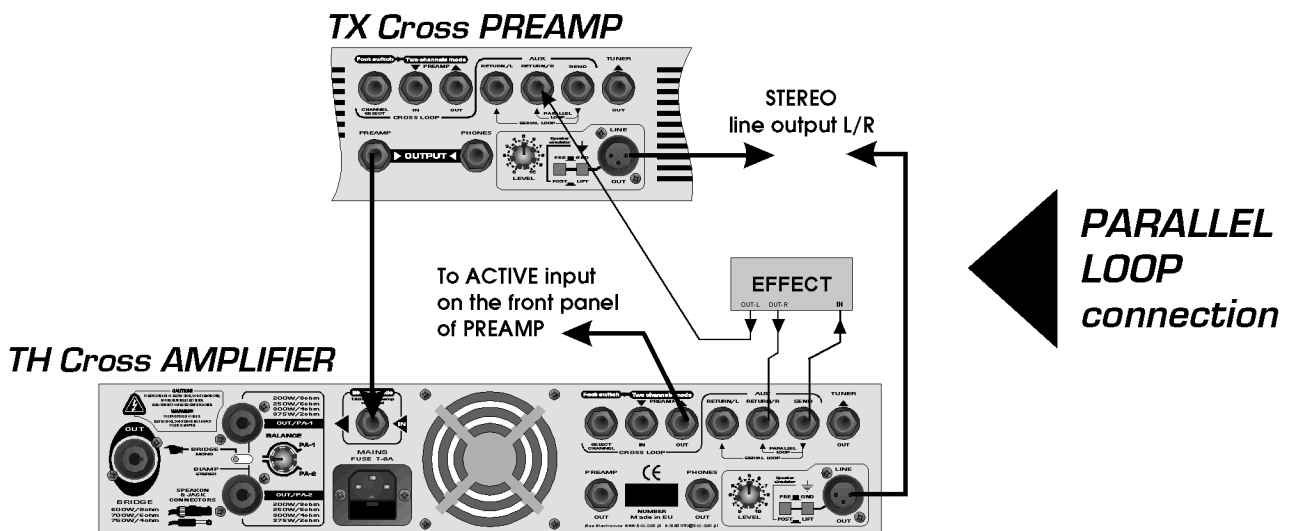
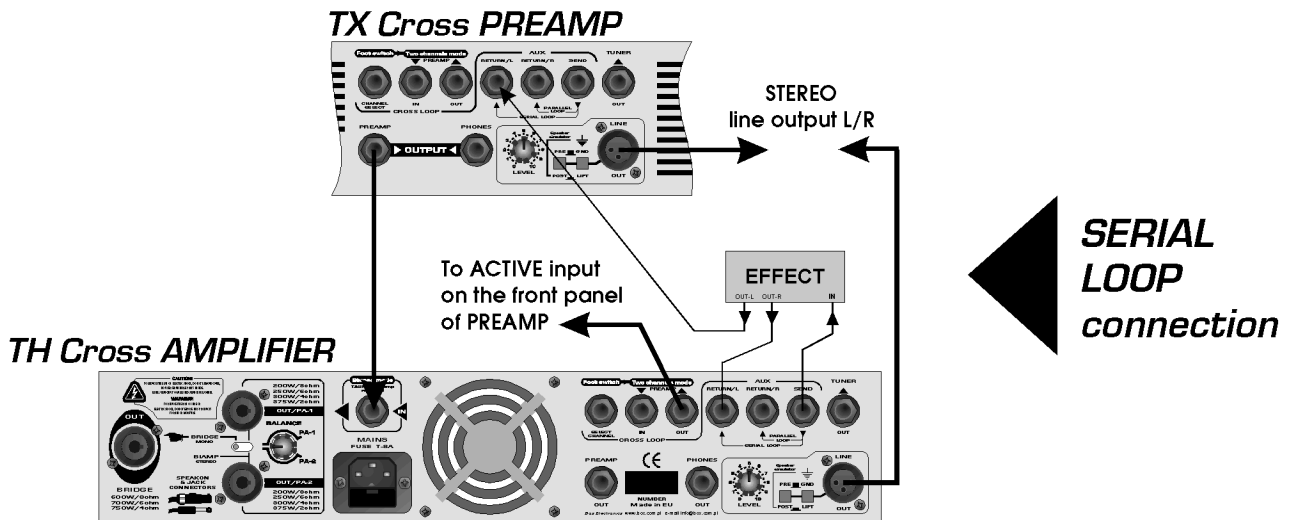

This configuration enables dual instrument connection with separate control of each instrument which is a very convenient option especially during a show.

TX Cross PREAMP

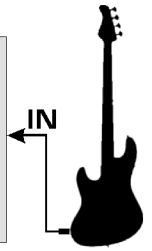
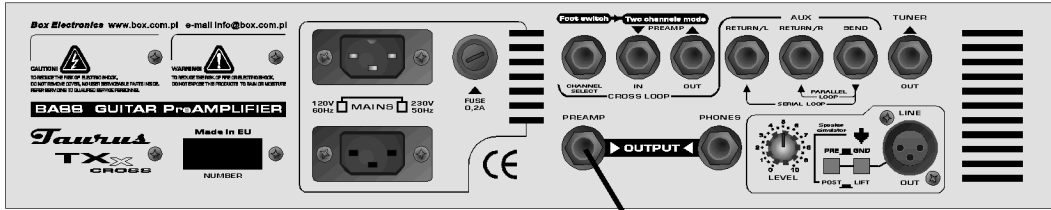

Attention! In TH Cross and TX Cross configuration the MASTER VOLUME is in TH Cross amplifier.

TH Cross AMPLIFIER

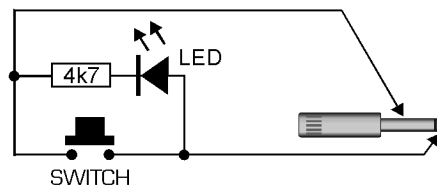
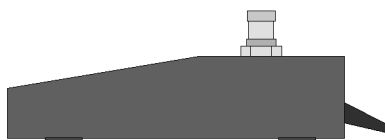
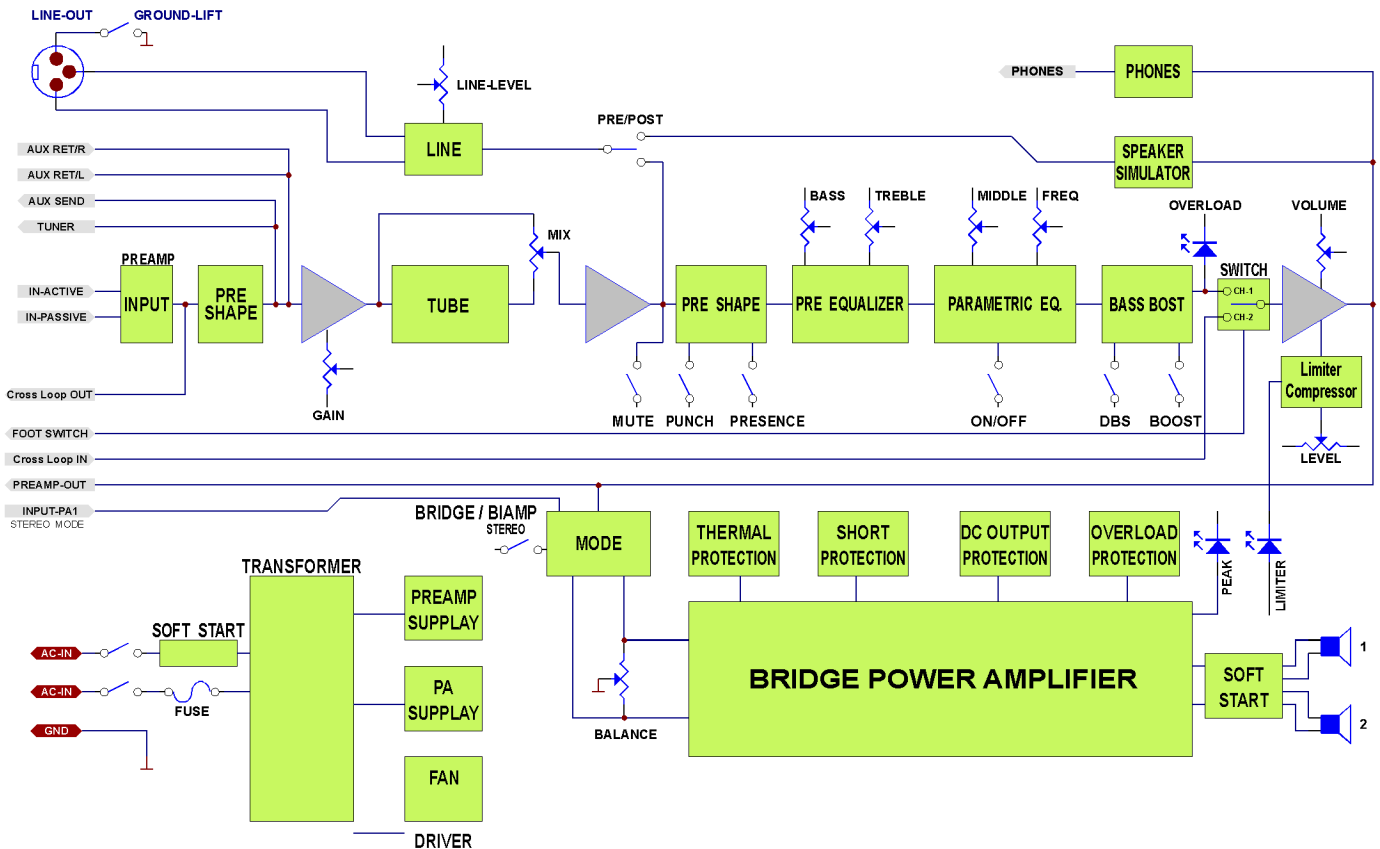
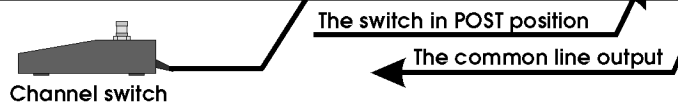
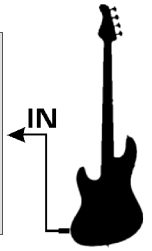
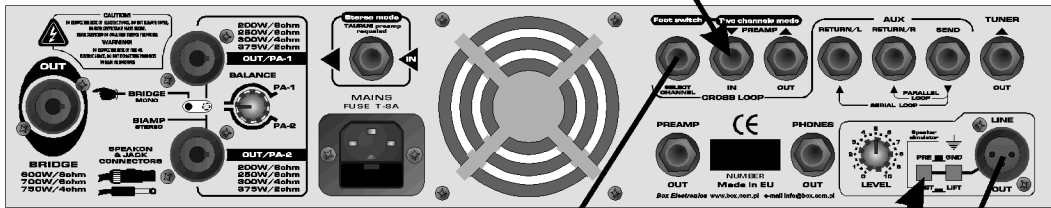

BRIDGE - MONO

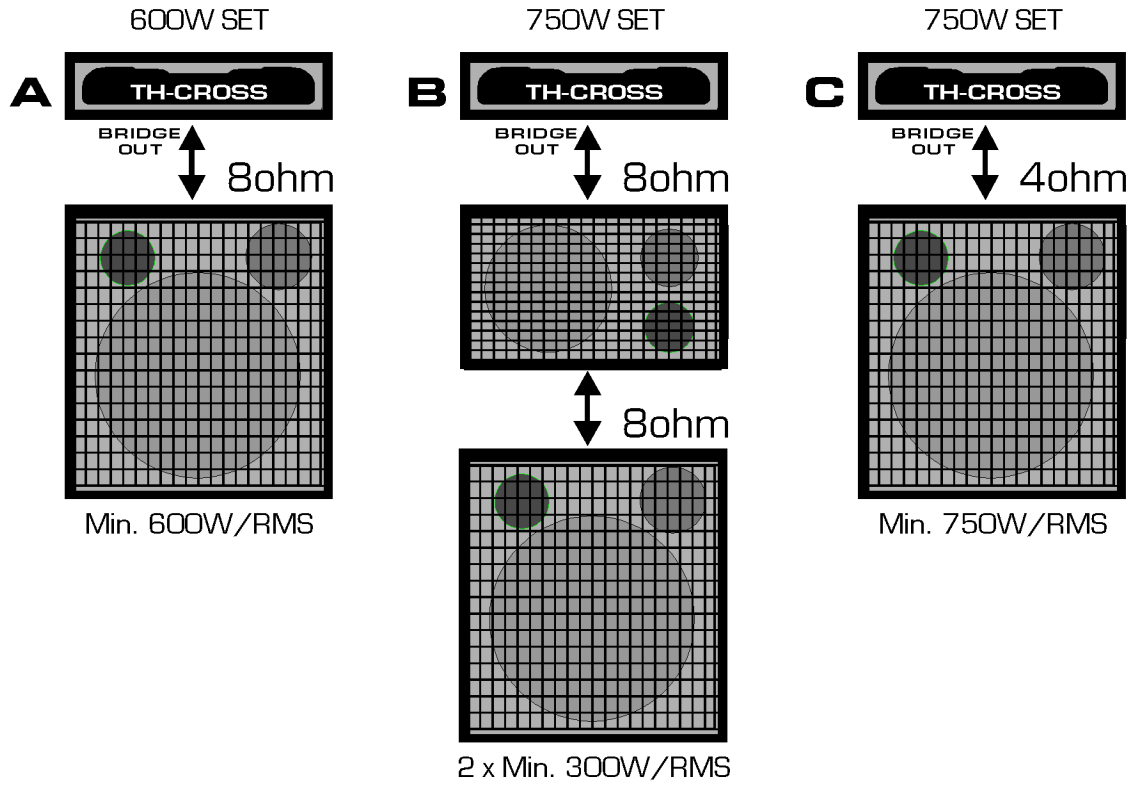

BIAMP - STEREO

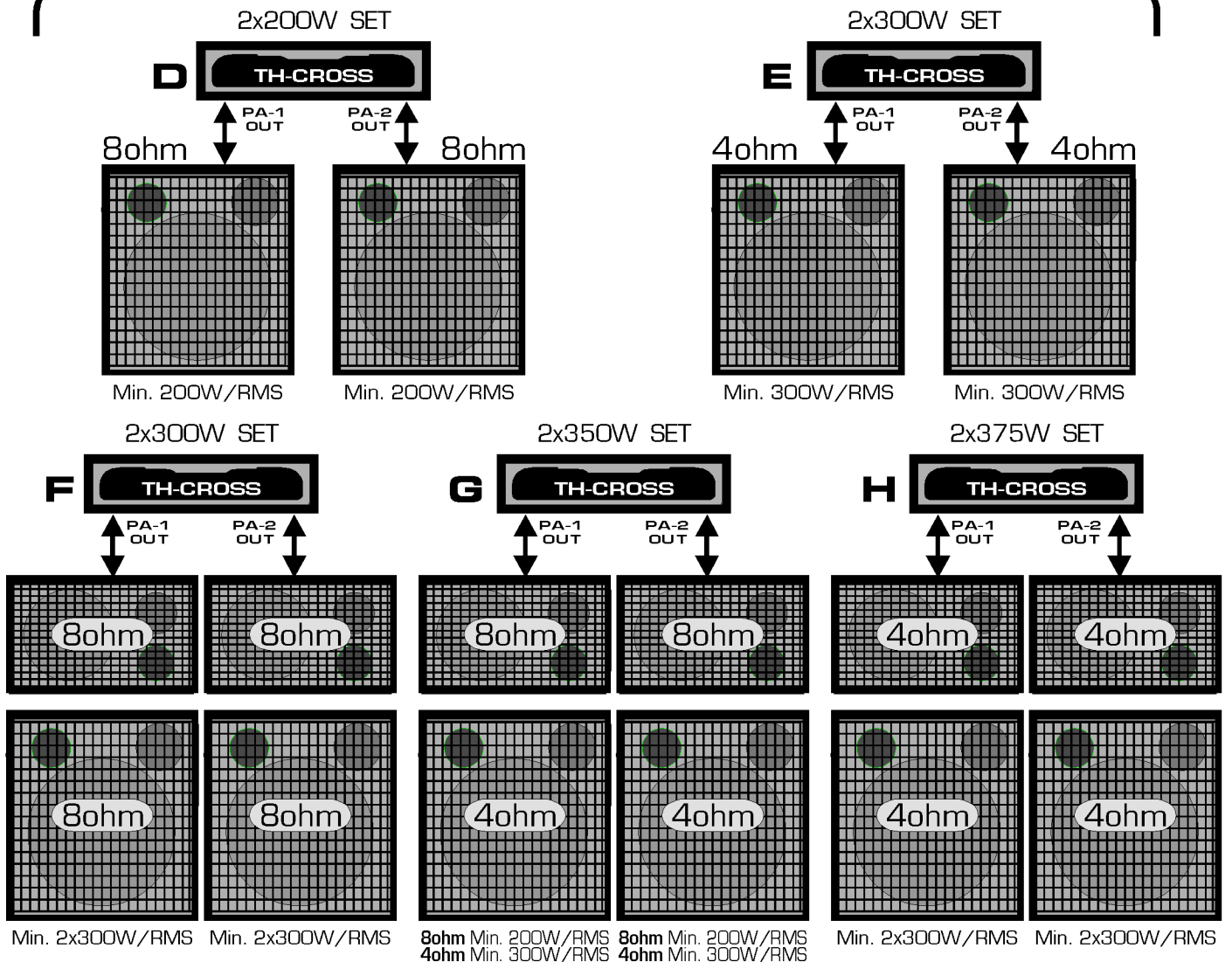

CE RoHS



Disposal of old Electrical & Electronic Equipment (Applicable throughout the European Union and other European countries with separate collection programs)

This symbol, found on your product or on its packaging, indicates that this product should not be treated as household waste when you wish to dispose of it. Instead, it should be handed over to an applicable collection point for the recycling of electrical and electronic equipment. By ensuring this product is disposed of correctly, you will help prevent potential negative consequences to the environment and human health, which could otherwise be caused by inappropriate disposal of this product. The recycling of materials will help to conserve natural resources. For more detailed information about the recycling of this product, please contact your local city office, household waste disposal service or the retail store where you purchased this product.

Taurus

www.taurus-amp.pl
info@taurus-amp.pl

Box Electronics ul. Cieszyńskiego 4
81-881 Sopot, POLAND
tel./fax +48 (058) 550 66 46, 551 90 05