

SME

The best pick-up arm in the world



INSTRUCTIONS

SERIES IV

MAGNESIUM TONE-ARM

Introduction

The Series IV precision pick-up arm makes available some of the design features and manufacturing technology developed for the more ambitious Series V.

The unique SME one-piece magnesium tone arm and other advanced features ensure a sonic performance worthy of the world's best cartridges.

This instruction manual has received the same attention to detail in its preparation as the Series IV itself. Please read it carefully before attempting installation and use. Time spent in this way will be well rewarded.

Contents

Page	
2	Introduction
4	General arrangement
5	Dimensions and specification
6	Packing list
7	Parts identification
8-9	Preparing the pick-up mounting board
9-10	Cartridge fitting
10	Cartridge lead replacement
11	Fitting the arm
12	Audio lead
12	Cartridge fitting, arm mounted on deck
12-13	Longitudinal balance
13	Vertical tracking force (VTF) adjustment
13-14	Arm height (VTA) adjustment
14-15	Horizontal tracking angle (HTA) adjustment
16	Positioning the armrest
16	Locking the base
16	Anti-skate control
17-18	Operation
18	Adjusting height of lift
18	Cleaning the arm lift
19	Appendix

General arrangement

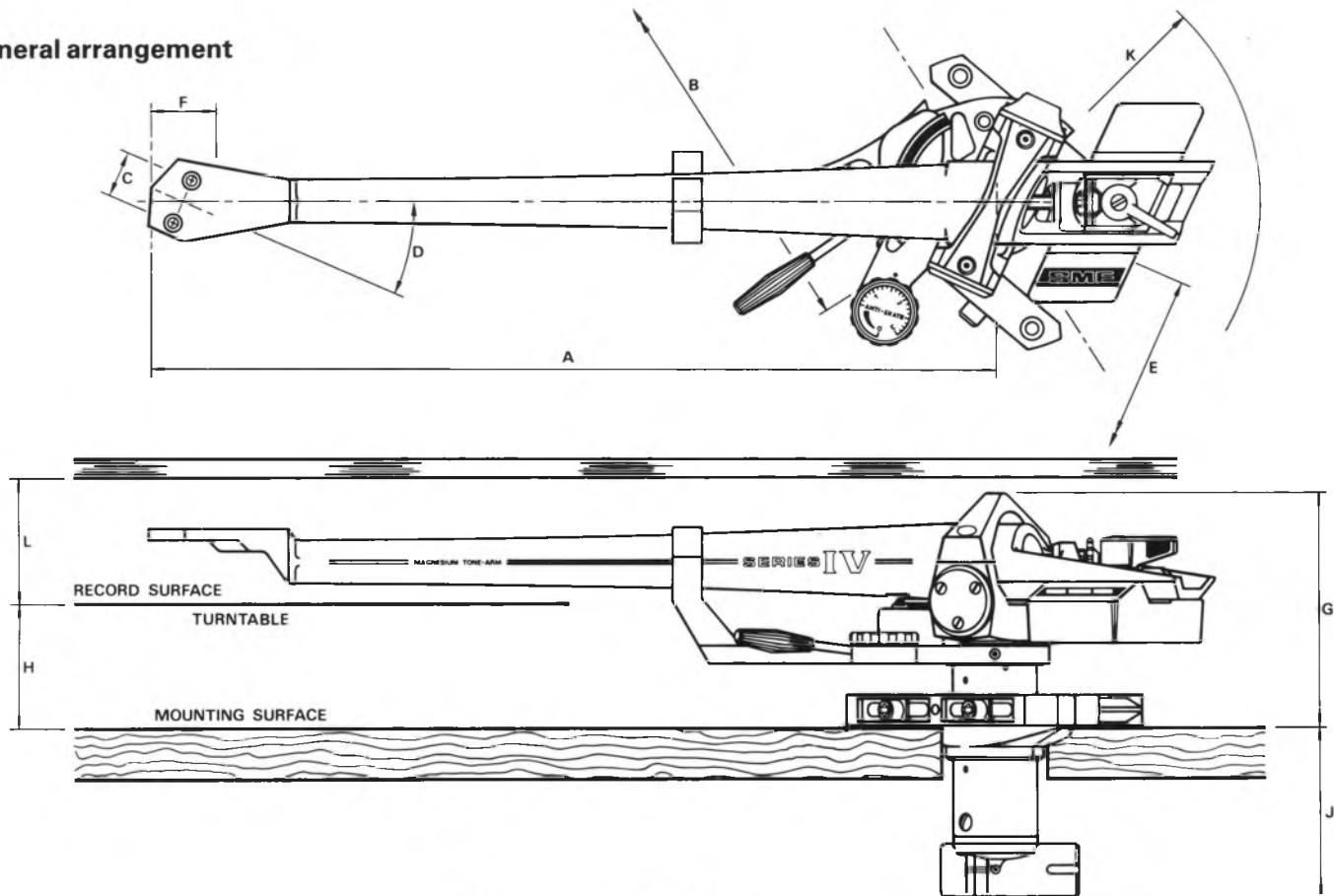

Dimensions

	mm
A – Distance from pivot to stylus	233,15
B – Distance from pivot to turntable centre	215,35
C – Cartridge fixing centres	12,7
D – Offset angle	23.635°
E – Linear offset	93,47
F – Overhang	17,8
G – Height above mounting surface	{ max 87,9 min 56,4
H – Height of record surface above mounting surface	{ max 57,9 min 26,4
J – Depth below mounting surface	56,75
K – Radial clearance for balance weight	73,0
L – Clearance between cabinet lid and record surface, assuming cartridge height at 17,0	35,0

Specification

Effective mass	10/11g
Cartridge balance range	5-16g
Vertical tracking force (at min cartridge weight)	0-3g
Maximum tracking error	0.012°/mm
Null points:	
Inner	66,04mm
Outer	120,9mm
Audio lead:	
Length	1,2m
Capacitance	≅ 140 pF/channel
Resistance	≅ 0.145 ohms/conductor
Internal wiring:	
Capacitance	≅ 15 pF/channel
Resistance	≅ 0.535 ohms/conductor
Output plug and socket	D.I.N. 5-pole 240°
Weight, net	700.0g

Packing list

The pack is the only one in which your Series IV precision pick-up arm can be safely transported. Please keep it for possible future use.

It contains the following:

Series IV precision pick-up arm

Instruction book

Mounting template

Shell hardware Finger lift and 2 washers
Set of 8 aluminium alloy screws
and 2 nuts

3,0 A/F ball-ended hexagon
wrench with handle

Mounting hardware Set of 4 socket cap screws,
4 nuts and 4 washers
2,5 A/F hexagon wrench

Audio lead

Alignment protractor

HTA key

0,89 A/F hexagon wrench

Guarantee card

Sachet of silica gel

Parts identification

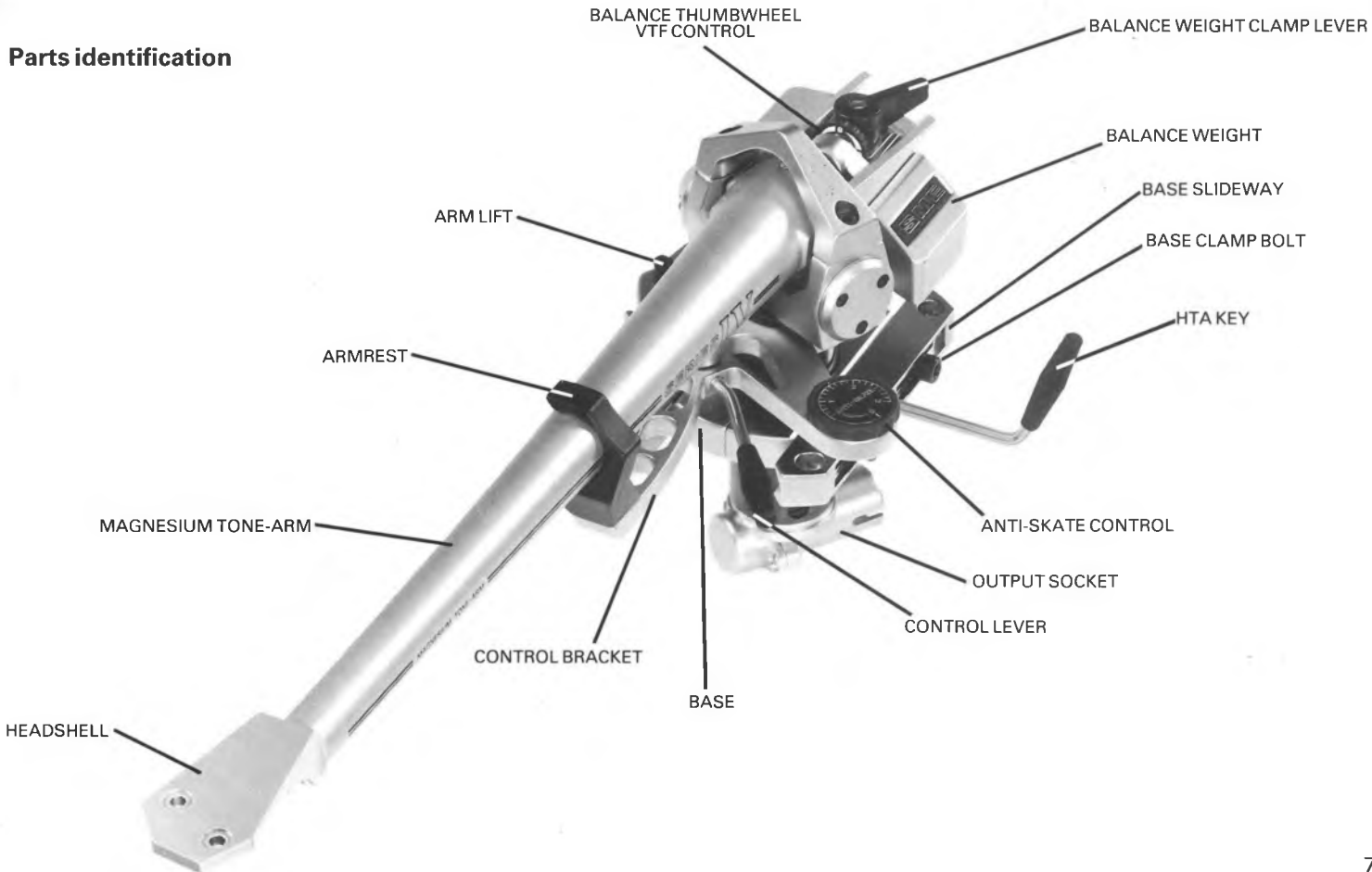

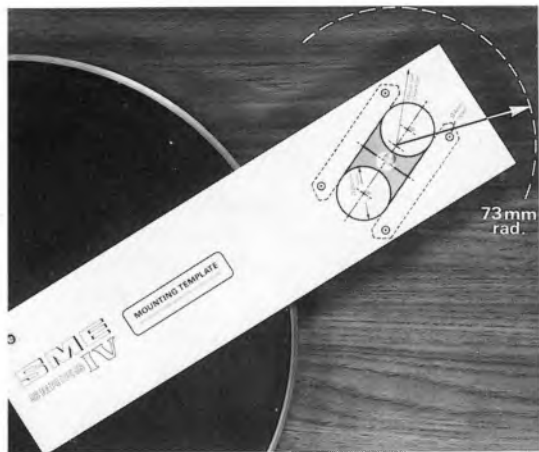

401 Preparing the pick-up mounting board

A number of decks have the pick-up mounting board already cut to accept SME arms, others will need to be prepared in accordance with the following instructions:

Pierce the centre point A of the mounting template to accept a pin or needle about 50mm (2") long. Place the template on the record spindle and keeping it parallel with the surface on which the arm will be mounted pass the pin vertically through the centre point A and spike it into the pick-up mounting board, 403 – figure 1.



402

Disengage the template from the spindle and maintaining the same alignment slide it down the pin and onto the pick-up mounting board, 403 – figure 2. This will position the base for maximum effective movement when adjusting the tracking angle (HTA), see 422-23-24. Anti-clockwise rotation from this position up to approximately 40 degrees can be made to meet individual needs and is not critical provided that the requirements of the alignment protractor can still be satisfied. Note that rear overhang requires a 73mm (2 7/8") radial clearance from the point shown on the template and care should be taken to see that this is available.

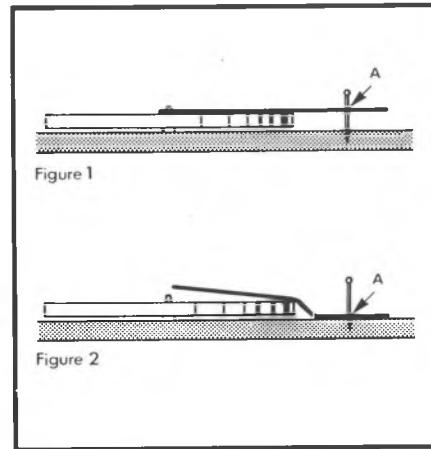

403



404 Preparing the pick-up mounting board (continued)

Using a scribe or compass point spike through the centre of points B and centres of the four fixing holes. Remove the template and with a compass mark two 28mm (1 1/8") diameter circles about the points B already centred. Join these together with two parallel lines to complete the marking out.

Drill four 4mm (5/32") diameter fixing holes and two 28mm (1 1/8") diameter holes. Cut away the remaining area to complete the slot and finish the edges with a file and glass paper. If a hole saw is not available drill a series of small holes around the inside of the line, saw out and file.

With suitable tools and technique the procedure is similar for materials other than wood.

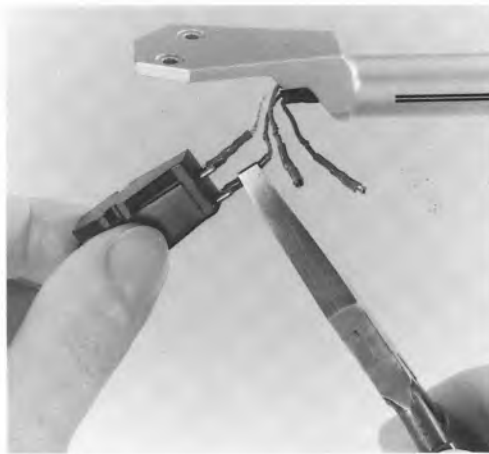

405 Cartridge fitting

Before fitting the cartridge see that its stylus guard is in position as a precaution against accidental damage.

The LCOFC cartridge leads have 1mm diameter receptacles for the arm and standard 1,25mm for the cartridge. The latter may require adjustment with pliers or a screwdriver blade for a snug fit on non-standard terminals.

Connections must never be made by direct soldering.

The coding is:

- Red – right channel signal
- Green – right channel ground
- White – left channel signal
- Blue/Black – left channel ground



406

Four lengths of alloy screws, nuts and washers are provided for cartridge fixing:

6,5mm	(1/4")
11mm	(7/16")
16mm	(5/8")
19mm	(3/4")

Select a pair, using the shorter if more than one length is suitable. For the purist, use without the finger lift is preferred but it is unlikely that the difference will be audible. When used, the two stainless steel washers should first be fitted to the counterbores in the headshell.

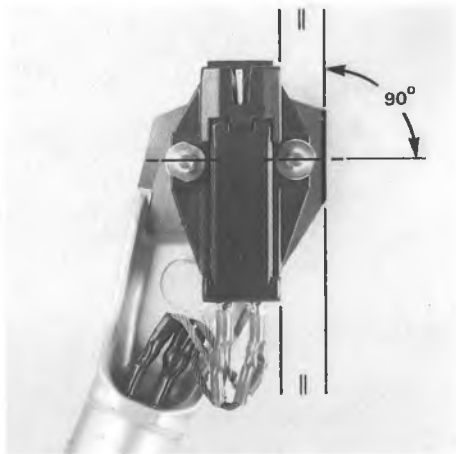

407 Cartridge fitting (continued)

Examine the top of the cartridge. It is important that it presents a good flat face to the underside of the headshell. Before final tightening check that the cartridge is lying parallel to the reference edge of the headshell as shown.

The majority of cartridges present a body height in excess of 16mm ($\frac{5}{8}$ "'). With cartridges below this a 3,2mm ($\frac{1}{8}$ "') aluminium spacer will be needed between the cartridge and shell for correct clearance between the tone-arm and the record edge, see 418. Part No. 5925 is available from SME Limited.

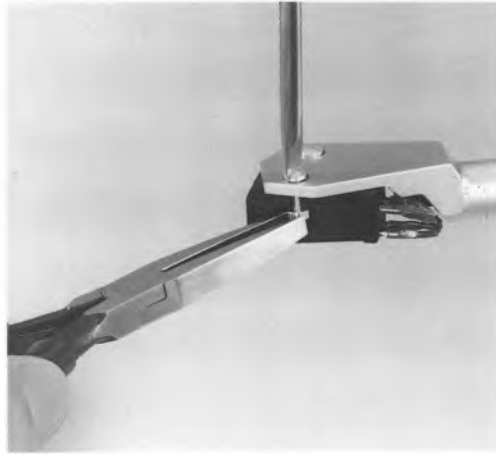

408

Tighten the cartridge fixing screws securely using a screwdriver which must be a good fit in the screw slots to avoid damage. Hold the nut with pliers if necessary to prevent rotation.

The screws are non-magnetic, damage can be caused if a screw is snatched by magnetic attraction whilst being offered up to the cartridge. For the same reason do not lay tools down nearby.

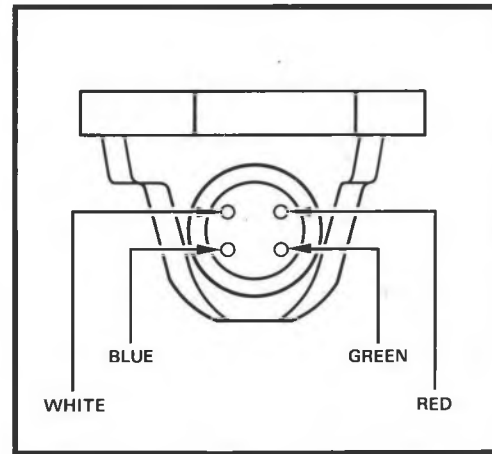

409 Cartridge lead replacement

The internal wiring terminates in a four pin plug at the back of the headshell. The LCOFC cartridge leads, Part No. 4899, can therefore be replaced and may be obtained from your dealer or direct from us.

They should be fitted with due regard to their colour coding as shown above, see 405.

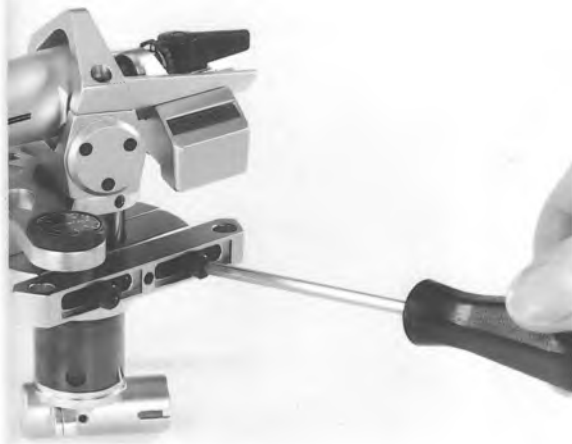

410 Fitting the arm

The base can be rotated on the pillar so that the clamp bolts are presented on the side giving the best access. Using the 3.0mm A/F hexagon wrench, see that both are lightly locked and then release by three-quarters of a turn only. This will enable the base to be moved on the pillar and also the base slideways to be moved in relation to the base.

The clamp bolts must not be re-locked until installation and adjustments have been completed. The movements are internally spring-loaded so settings will not be lost in the meantime.

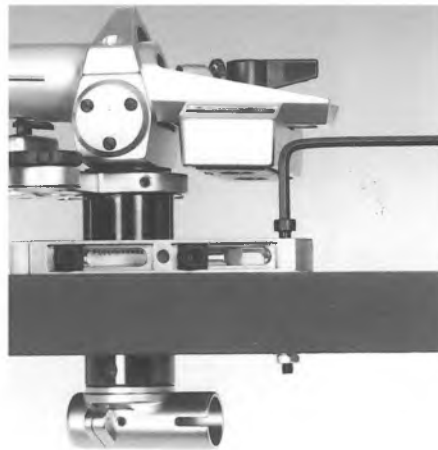

411

Move the two base slideways fully backwards in relation to the base. Position the arm on the pick-up mounting board and insert two of the M3 socket cap screws into the rear mounting holes. Fit the nuts and washers under the board so that the screws are pulled home but do not fully tighten. The screws are 22mm ($\frac{7}{8}$ ") long and suit the majority of applications. For an exceptionally thick mounting board they should be replaced with M3×35mm ($1\frac{3}{8}$ ") long socket cap screws. Part No. 5893/35 available direct from us in the event of difficulty.

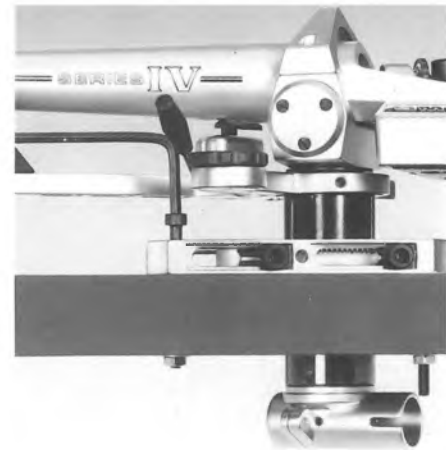

412

Move the arm into the fully rearward position, either manually or using the HTA key, see 421. Insert the two remaining screws and fit the nuts and washers. The four screws should now be firmly and evenly tightened using the 2.5mm A/F hexagon wrench. Excessive tightness should be avoided, and care taken that the fine finish of the arm is not marred by the wrench coming into contact with it. It may be more convenient to use this reversed, with the long leg engaging the screw.

The arm height has been set at the factory to suit the pack. At this point it may be altered as required, see 418-19-20.



413 Audio lead

Insert the output plug. The socket rotates through 315 degrees allowing it to be moved into the best position. When using a floating deck a generous loop should be formed in the lead to minimise mechanical coupling.

The ground lead serving the arm should be connected to the ground terminal of the pre-amp and those from the phono plugs to the ground terminal on the piece of equipment to which the plugs are connected, ie. transformer, head amp or pre-amp. If the turntable has a ground terminal it should also be connected to the pre-amp but not if an electrical path from the deck already exists via the arm ground, due to a grounded metal mounting board for instance.

The system has been designed for a high S/N ratio and if this is not achieved, multiple ground paths or the over-proximity of mains equipment will be likely causes.

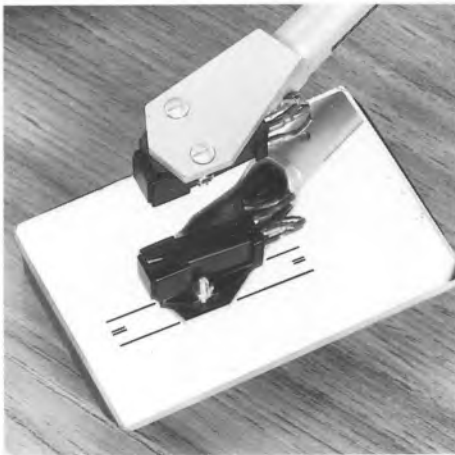

414 Cartridge fitting – arm mounted on deck

To fit or change the cartridge after the arm has been mounted, see 405-06-07-08.

Check the alignment of the cartridge with the reference edge of the headshell, viewing it in a mirror whilst highlighting it with an electric torch. Re-check the adjustment after tightening the screws.

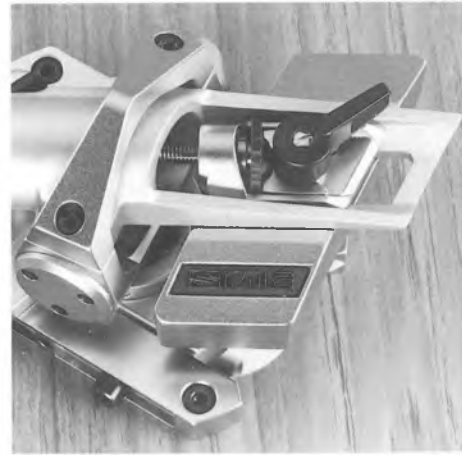

415 Longitudinal balance

If a detachable stylus guard was used it should now be removed, thereafter handling the arm with suitable caution.

The balance weight is unlocked by moving the clamp lever anti-clockwise to its full extent.

The action of the clamp lever can be adjusted as follows:

Remove the central screw from the clamp lever and lift it upwards off its boss with a slight rocking movement. Replace in a new position one spline at a time, anti-clockwise to increase locking tension and clockwise to reduce it. Replace the central screw.



416 Longitudinal balance (continued)

Check that the anti-skate control is set at zero, see 427. Position the arm so that it is clear of the armrest and the cartridge is clear of the turntable. Move the control lever into the lowered position, see 430. Balance the arm by rotating the leadscrew thumbwheel which moves the balance weight forwards or backwards. Adjust until the arm with cartridge fitted is either level or slightly low at the front when the clamp lever is re-locked.



417 Vertical tracking force (VTF) adjustment

For safety the lever of the lowering control should now be moved into the raised position, see 431. The thumbwheel carries arrows and letters A-B-C-D at quarter turn intervals. To apply VTF note the position of one of the letters and rotate the thumbwheel in the direction of the arrows. One full turn applies 0,5 gram or 0,125 gram for each letter. For example, to apply 1,5 gram – three complete turns of the thumbwheel will be required.

When reducing VTF by opposite rotation of the thumbwheel, move it slightly further than required so that final adjustment is always in a forward direction. Re-lock the balance weight clamp lever.

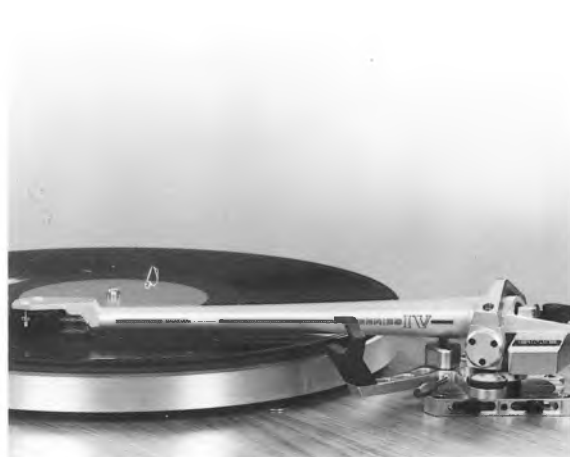

418 Arm height (VTA) adjustment

Use an old but unwarped record for the following procedures in case of accidental damage. Place the arm about halfway across the record and move the control lever forward to lower it into the playing position. Arm height is adjusted by moving the main pillar upwards or downwards in the base. It is convenient to do this with one hand on each side of the control bracket. Spring loading ensures that positioning will be maintained until the base is locked at a later stage. Set visually so there is approximately 3mm (1/8") clearance between the underside of the tone-arm and the edge of the record.

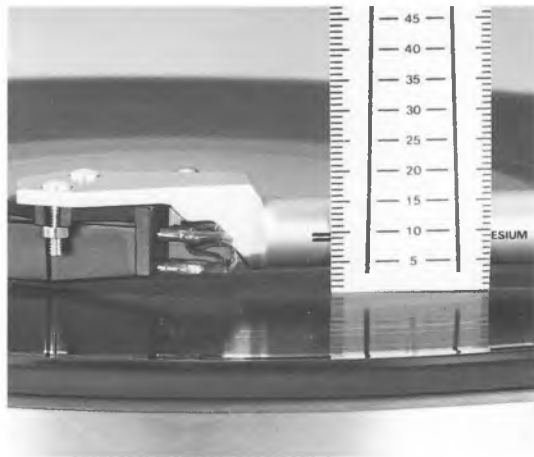

419 Arm height (VTA) adjustment (continued)

In standard operation the mounting surface of the cartridge, underside of the shell and centre line of the tone-arm should all be parallel with the surface of the record. The alignment protractor has been printed to act also as a height gauge in conjunction with the black lines on the side of the tone-arm. Measure the distance from the surface of the record to the upper of the two lines at the front of the tone-arm using the left-hand scale.

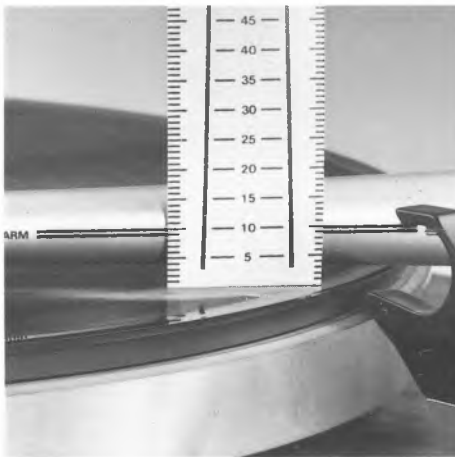

420

Re-position the protractor about 6mm (1/4") from the edge of the record. Using the right-hand scale repeat the measurement and compare it with the first. Finally adjust the arm height, see 418, until similar readings are obtained, indicating that the tone-arm is parallel with the surface of the record.

Other dispositions can of course be accommodated and if the readings are noted can be quickly implemented for special needs.



421 Horizontal tracking angle (HTA) adjustment

Insert the HTA key into the socket situated centrally in either of the base slideways. Use a light pressure, rocking it slightly to ensure full engagement of the pinion with the toothed rack in the base. Rotation of the key in either direction will now cause the base to move between the slideways. Do not use force. If the movement is tight, check that the clamp bolts are sufficiently released; also that the cut-out in the pick-up mounting board is affording proper clearance. When all is well, rotate the key to traverse the arm into its fully forward position.



422 Horizontal tracking angle (HTA) adjustment (continued)

With the record still on the turntable, place the alignment protractor on the record spindle. Check that the anti-skate control is at zero and that the VTF has been set to suit the cartridge in use. The stylus position on the protractor is indicated by crossed lines. Place it so that the stylus drops into the indent formed at their intersection, taking the utmost care not to touch or knock the tone-arm. Rotate the HTA key to move the tone-arm and protractor backwards until, when viewed directly from above, their outlines coincide.

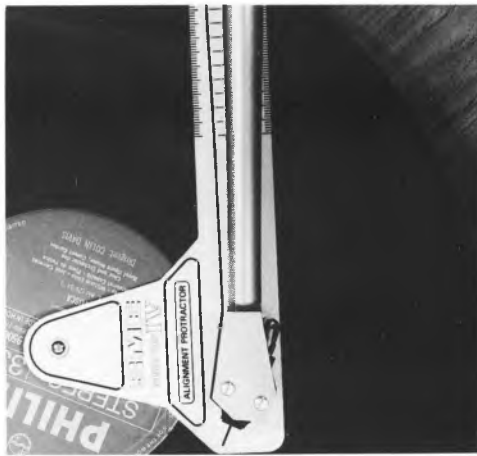

423

Movement has been made too far and opposite rotation of the HTA key is required to correct it.

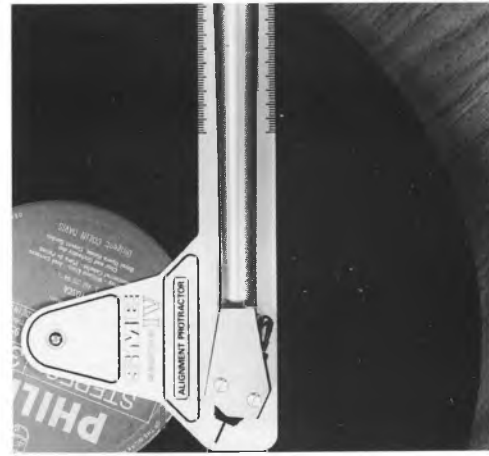

424

Most cartridges have a stylus – fixing hole centre distance of 9,5mm ($\frac{3}{8}$ "). Correctly adjusted with these, the outlines of the tone-arm and protractor will coincide when viewed directly above the centre line of the tone-arm. With others according to the position of the stylus, it will be necessary to view slightly to the left or right of the centre line; the only requirement for correct HTA being that the outlines appear to coincide along their length as shown.

Place the arm in the armrest and remove the alignment protractor.



425 Positioning the armrest

Keeping the tone-arm in the armrest swing it radially until the left-hand front edge of the shell is 53mm (2³/₃₂"") from the edge of the turntable. The measurement is not critical within $\pm 3\text{mm}$ ($1/8$ "") but the accuracy of the anti-skate control will be affected if this is exceeded.

Re-check the arm height setting, see 418-19-20.



426 Locking the base

Tighten the two clamp bolts evenly and tightly. Excessive force is unnecessary and should be avoided.



427 Anti-skate control

The dial is calibrated and should be set to correspond with the VTF in use. Rotate the control until the required setting coincides with the index point.

Requirements are dependent on a number of variables and the recommended setting will be found a good compromise. The situation lends itself to experiment. Listen for any discrepancy between channels. If the left channel mistracks, reduce the setting, and if the right channel mistracks increase it.



428 Operation

With the control lever in the raised position move the tone-arm out of the armrest.



429

Position the arm so that the stylus is over the selected record groove.



430

To lower the stylus onto the record move the control lever forward. This will set the lowering control in motion, at which point it will take over movement of the lever, giving a smooth, controlled descent.



431 Operation (continued)

To raise the stylus from the record move the control lever back to its original position. When the arm is not in use it should always be returned to the armrest for safety.



432 Adjusting height of lift

The raising and lowering control is set to suit the majority of cartridges but the height raised above the record can be changed to meet individual needs. The small hole in the centre of the arm lift provides access to the adjustment screw. Insert the long leg of the 0,89 A/F hexagon wrench through this hole to engage the screw. Clockwise rotation will decrease the height of lift; anti-clockwise rotation will increase it. The adjustment is sensitive so the wrench should be turned only a few degrees at a time. Apply firm downward finger pressure to the arm lift after each clockwise rotation of the adjustment screw.

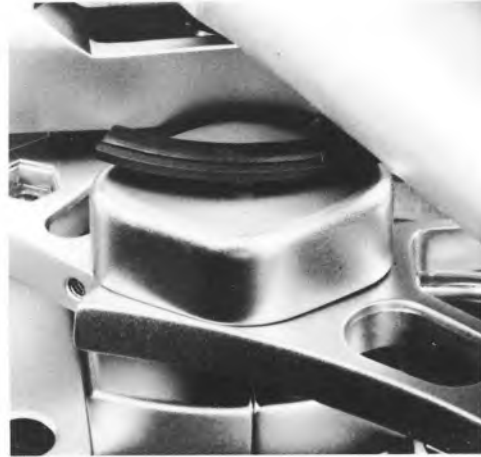

433 Cleaning the arm lift

If the arm drifts outwards during raising or lowering it usually indicates the presence of contaminant on the rubber pad in the arm lift. To restore positive working, wipe the pad with a damp cloth and repeat with a paper tissue until dry. Clean the underside of the tonearm in the same manner where it contacts the rubber pad.

Appendix

We hope these instructions have made the installation of your Series IV precision pick-up arm straightforward. Care for it as you would a camera. Do not attempt to take it to pieces. Do not apply oil or other lubricant to any part of it.

If you have a problem concerning operation or service, contact us at the address overleaf in the first instance, quoting the unit's serial number. Do not send the arm to us unless requested to do so. We provide a quick, efficient service through our agents or direct from the factory to any part of the world.

SERIES IV
MAGNESIUM TONE-ARM

MANUFACTURED BY · SME LIMITED · STEYNING · SUSSEX · BN4 3GY · ENGLAND

☎ (0903) 814321 · ☎ 877808