

REVELATOR

PASSIVE RADIATOR

23W/0-00-02

The Revelator woofers and subwoofers features very rigid cones in paper or aluminium that operates as a piston over a wide frequency range, it results in very low distortion and a smooth and well behaved frequency response as well as perfect transient reproduction.

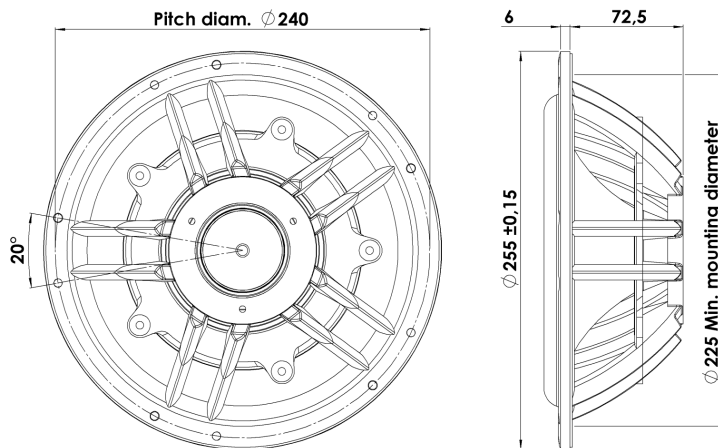

KEY FEATURES:

- Optimized for 23W/4557T02
- Black Anodized Rigid Alu Cone
- Die cast Alu Chassis
- Adjustable Weight for Optimum Fres
- Long Throw Surround

T-S Parameters

Resonance frequency [fs]	11 Hz
Mechanical Q factor [Qms]	11.50
Electrical Q factor [Qes]	-
Total Q factor [Qts]	-
Force factor [Bl]	- Tm
Mechanical resistance [Rms]	2.29 kg/s
Moving mass [Mms]	400 g
Suspension compliance [Cms]	0.57 mm/N
Effective diaph. diameter [D]	172 mm
Effective piston area [Sd]	232 cm ²
Equivalent volume [Vas]	43.3 l
Sensitivity (2.83V/1m)	- dB
Ratio Bl/√Re	- N/√W
Ratio fs/Qts	- Hz

Notes:

IEC specs. refer to IEC 60268-5 third edition.
All Scan-Speak products are RoHS compliant.
Data are subject to change without notice.
Datasheet updated: February 24, 2011.

Electrical Data

Nominal impedance [Zn]	- Ω
Minimum impedance [Zmin]	- Ω
Maximum impedance [Zo]	- Ω
DC resistance [Re]	- Ω
Voice coil inductance [Le]	- mH

Power Handling

100h RMS noise test (IEC 17.1)	- W
Long-term max power (IEC 17.3)	- W

Voice Coil and Magnet Data

Voice coil diameter	- mm
Voice coil height	- mm
Voice coil layers	-
Height of gap	- mm
Linear excursion	± - mm
Max mech. excursion	± 20 mm
Unit weight	1.2 kg



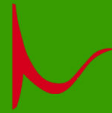

REVELATOR

PASSIVE RADIATOR

23W/0-00-02

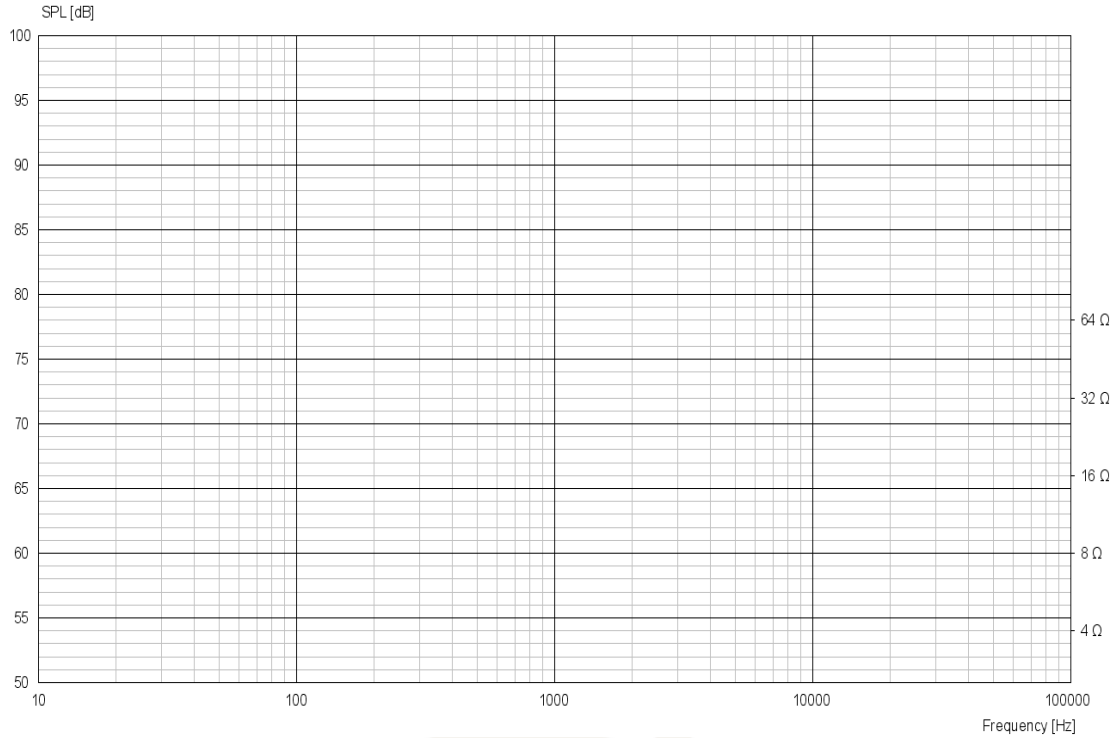

Advanced Parameters (Preliminary)

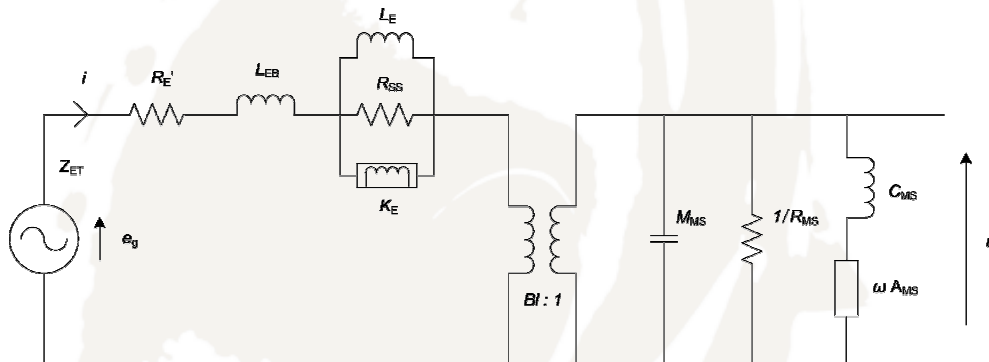

Electrical data:

Resistance [Re']	- Ω
Free inductance [Leb]	- mH
Bound inductance [Le]	- mH
Semi-inductance [Ke]	- SH
Shunt resistance [Rss]	- Ω

Mechanical Data

Force Factor [BI]	- Tm
Moving mass [Mms]	400 g
Compliance [Cms]	0.395 mm/N
Mechanical resistance [Rms]	1.893 kg/s
Admittance [Ams]	0.00994 mm/N

