



# OPERATING & ASSEMBLY INSTRUCTION

## NAC3FX | powerCON TRUE1

### OPERATING INSTRUCTION

#### Application:

The powerCON TRUE1 system is certified as connector with breaking capacity according IEC 60320, VDE 0625. It is intended for use as appliance couplers and interconnection couplers. It serves to supply power to an appliance and from an appliance to another equipment. To be installed by qualified person only.

#### Connector Assignment:

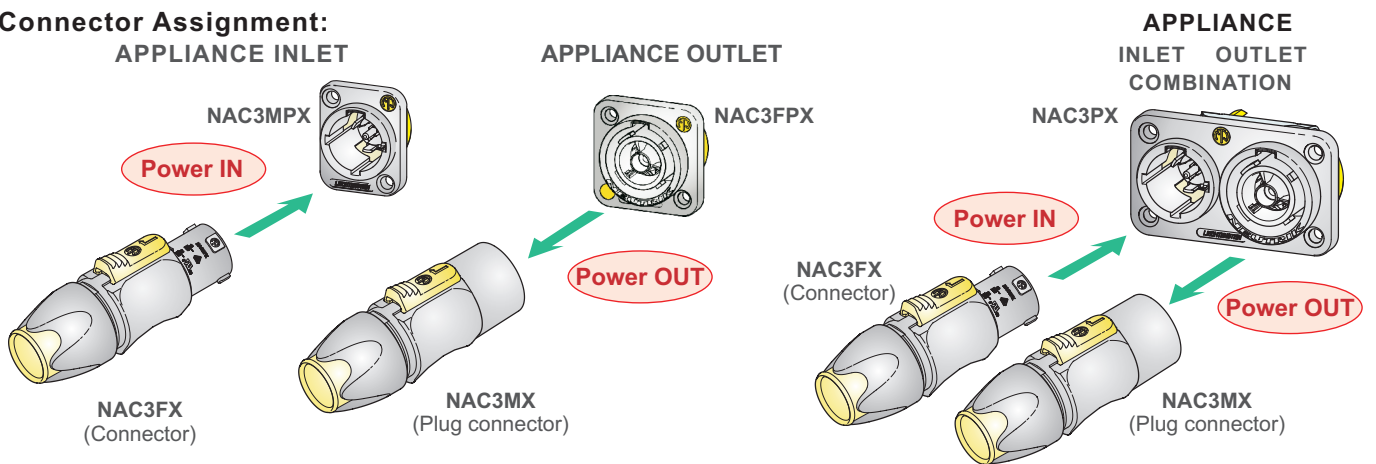

### ASSEMBLY INSTRUCTION

<b>Approval based:</b>	<b>VDE</b> EN 60320-1/EN60320-2-2	<b>UL</b> UL 498 / CSA C22.2 No. 182.3
<b>Rating:</b>	250 V ac / 16 A	250 V ac / 20 A
<b>Cable Type:</b>	H05VV-F3G 1.0 mm <sup>2</sup> , Length max. 2 m H05VV-F3G 1.5 - 2.5 mm <sup>2</sup>	SJT 3 x 12 AWG
<b>Strain Relief:</b>	White chuck	Black chuck
<b>Cable O.D.:</b>	6.3 - 11.4 mm	9.5 - 12.0 mm

- A** Place bushing and chuck over the cable.

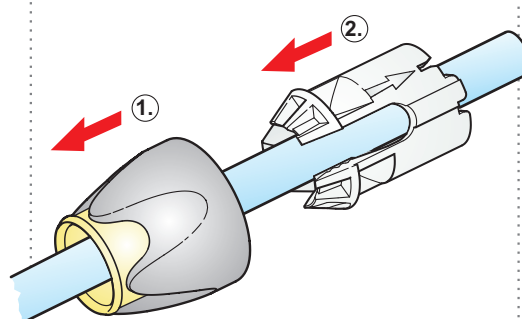

- B** Prepare cable as shown.

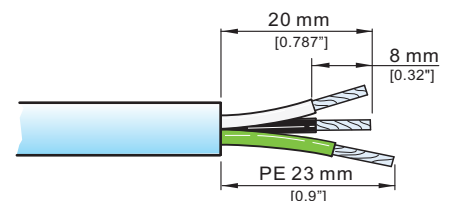
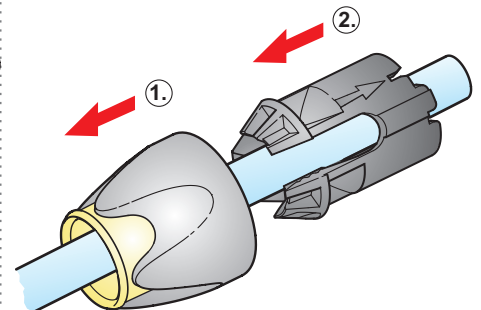
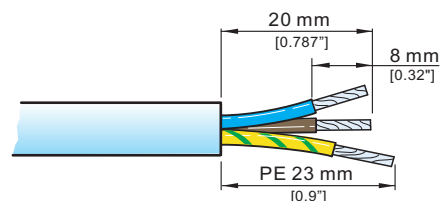



C

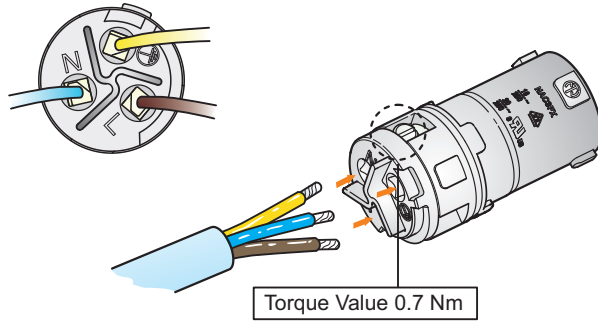

Slide the cable into the contacts and clamp with the screw.

Wiring	VDE	UL
L ⇒	brown	black
N ⇒	blue	white
⊥ ⇒	green / yellow	green

D

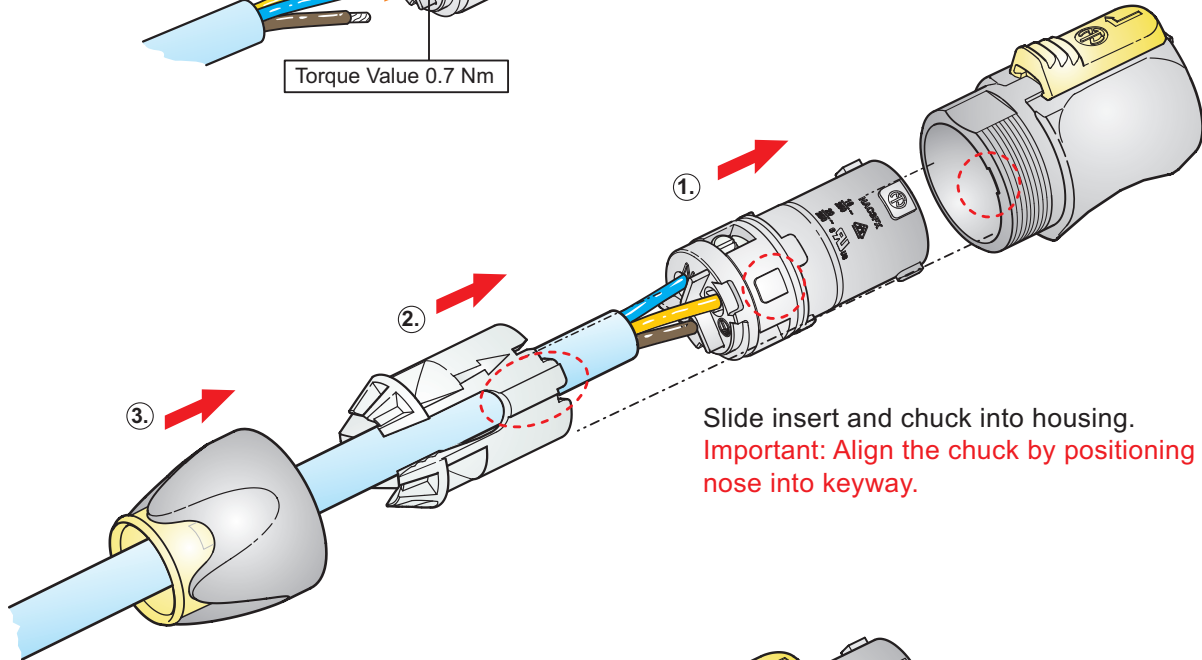

Slide insert and chuck into housing.  
Important: Align the chuck by positioning the nose into keyway.

E

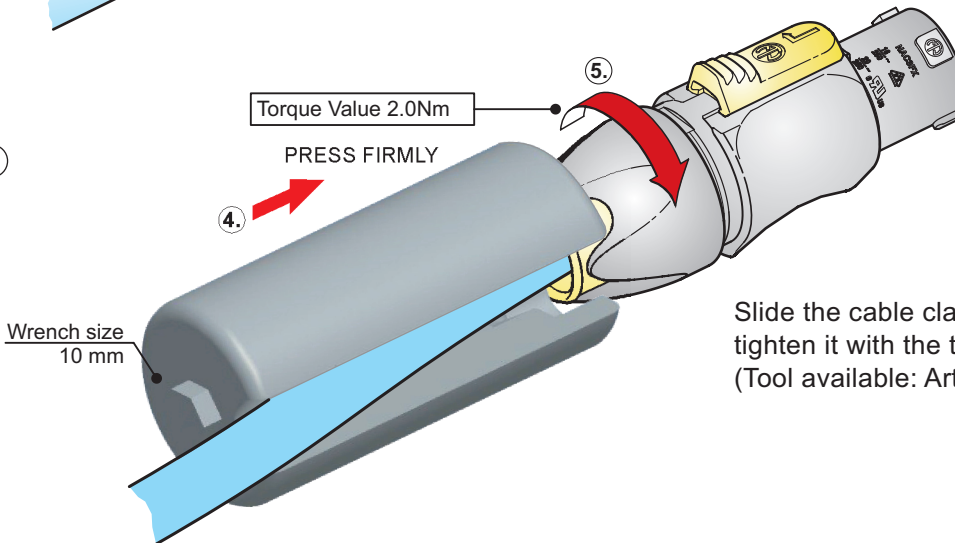

Slide the cable clamp bushing up the cable and tighten it with the tool as shown.  
(Tool available: Art. No. HTAC)

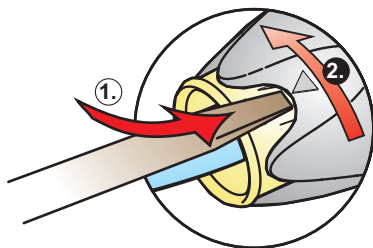

**Disassembly (open twist lock):**

1. Press with screw driver to unlock (at ▼)
2. Turn bushing while still pressing locking.