



D'Addario 2018



D'Addario
2018

TABLE OF CONTENTS

D'ADDARIO STRINGS

Electric Guitar Sets	8-10
Acoustic Guitar Sets	10-11
Classical Guitar Sets	12-13
Bass Guitar Sets	14-16
Other Sets	17-18
Multi-Packs	19
Single Strings	20-24
Kits & Displays	25-26

D'ADDARIO ACCESSORIES

Tuners	30-32
Capos	33-38
Musical Fitness	39
Maintenance Tools & Support	40-43
Polishes & Cloths	44-45
Humidity Control	46-48
Soundhole Accessories	49
Guitar Slides	50
Hardware	51-52
Hearing Protection	52
Straps	53-80
Picks	81-88
Cables	89-98
Adapters	99
Displays & Assortments	100-102

EVANS PERCUSSION

Tom & Snare Drumheads	106-112
Bass Drumheads	113-117
Custom Drumheads	117
Afro Cuban & Conga Drumheads	118
Pipe Band & Marching Drumheads	119-121
Concert & Timpani Drumheads	122-124
Percussion Accessories	125-130
Displays & Assortments	131-133

PROMARK DRUMSTICKS

American Hickory Drumsticks	136-139
Artist Series American Hickory Drumsticks	139-141
Shira Kashi Oak Drumsticks	142-143
Artist Series Shira Kashi Oak Drumsticks	144
American Maple Drumsticks	145
Artist Series American Maple Drumsticks	145
Brushes & Rods	146-147
World & Alternative Sound Sources	148
Drum Set Accessories	149-150
Pipe Band Drumsticks	151
Marching	152-155
Concert	156
Band & Orchestral	157
Keyboard Mallets	158-160
Timpani Mallets	161
Band & Orchestra Accessories	162
Displays	163-164

D'ADDARIO ORCHESTRAL

Violin Strings	168-170
Viola Strings	171-172
Cello Strings	173-174
Bass Strings	174-176
Rosin & Accessories	177
Displays	177
Instrument Care	178-179
Music Paper	180

D'ADDARIO WOODWINDS

Reeds	184-190
Mouthpieces	191-195
Ligatures & Caps	196-197
Instrument Straps	198-199
Reed Cases & Accessories	200-201
Instrument Care	202-203
Displays	204

TABLE OF CONTENTS

DANELECTRO

Guitars	206-207
Pedals, Amps, Accessories	208

SUZUKI

Harmonicas	209-214
Microphones & Accessories	214-215
Melodions	216-217

BEAVERCREEK GUITARS

Steel String	218-219
Travel Size	220
Nylon String & Crossover	221
Bluegrass	222
Ukuleles	224-225

TUNE-BOT

Drum Tuner	226
------------	-----

TYPHOON

Amplifiers	226
------------	-----

SHADOW ELECTRONICS

Fretted Pickups, Preamps & Accs.	227-228
Bowed Pickups, Preamps & Accs.	228-229
Other Accessories	229

ZEV INSTRUMENTS

Violins & Recorders	230
---------------------	-----

ENERGIZER

Energizer Max and Industrial	231
------------------------------	-----

TYCOON PERCUSSION

Percussion Series	232
Cajons	233-234
Bongos, Congas & Djembes	234-235
Bags, Stands and Accessories	235
Ethnic Drums & Timbales	236-237
Hand Held Percussion	238-243
Percussion Rack & Replacement Heads	243

SOLUTIONS

Bags	244-245
Machine Heads	246
Stands	247

D&A STANDS

Stands	248-249
--------	---------

STRUKTURE STANDS

Guitar & Microphone Stands	250
Music Stands	251
Keyboard & Speaker Stands, Tablet Mount	251

MUSIC STAMPS

Music Stamps	252
--------------	-----

DAVA PICKS

Standard, Jazz Shape, Other Picks	253
-----------------------------------	-----

KAZOOBIE KAZOOS

Kazoobie Kazoos	254
-----------------	-----

PLAYERS CIRCLE JUST GOT LOUDER.

Good news! We've expanded your favorite rewards program. Now, Players Circle includes D'Addario Orchestral, D'Addario Woodwinds, and D'Addario Percussion, and can be accessed from select countries from around the world.

STRINGS

GUITAR+



NEW CAPABILITIES, NEW PRODUCTS

As part of our long-term commitment to product innovation, D'Addario continues its investment in research and development to enable advanced wire coating technologies, exceptionally precise polymer extrusion, and generational improvements to our automated manufacturing equipment. With the addition of our state-of-the-art wire drawing mill, specifically designed and optimized to produce bronze alloy wrap wires, D'Addario is now producing bronze wire in-house with unsurpassed quality. This new capability delivers exceptional tone and feel along with a lustrous appearance to products already considered best-in-class.



D'Addario continues to use such advancements to expand our premium product lines, adding **NYXL** string sets for pedal steel, double ball end strings for Steinberger instruments, and a wider range of gauge combinations for electric bass. Following the success of **Nickel Bronze** strings for acoustic guitar, we extended the product line to include balanced tension sets and added a full selection of Nickel Bronze gauges for mandolin.

In response to consumer demand and purchasing preferences for our best-selling string sets, D'Addario now offers **3-set multi-packs** of our fastest-moving items, including Phosphor Bronze, 80/20 Bronze, and EXP coated strings for acoustic guitar, Pro-Arté normal and hard tension string sets for classical guitar, and nylon Classics.



D'Addario also carries on its long-term commitment to environmental responsibility, as **Playback**, our string recycling program, continues to grow. Since its launch in January 2016, D'Addario has recycled over one million instrument strings. We expect to more than double this quantity by the end of 2018, at a rate of over 100,000 strings recycled per month. Our U.S. dealer program now accounts for a full third of this volume, drawing consumers to drop off used strings at designated collection points in retail locations. Playback is a music industry success story supported by the dealers, instrument manufacturers, technicians, educators, and players who contribute strings for recycling.

TOP SELLERS & MUST HAVES



NYXL REGULAR LIGHT

NYXL1046
(See page 8)

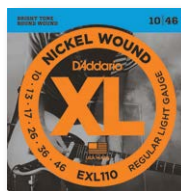

XL NICKEL WOUND REGULAR LIGHT

EXL110
(See page 8)



NYXL BASS

NYXL45105
(See page 14)

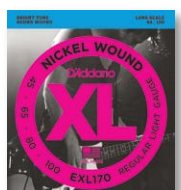

XL BASS NICKEL WOUND REGULAR LIGHT

EXL170
(See page 14)



NICKEL BRONZE LIGHT

NB1253
(See page 10)

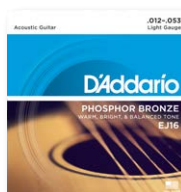

PHOSPHOR BRONZE LIGHT

EJ16
(See page 10)



EXP PHOSPHOR BRONZE LIGHT

EXP16
(See page 11)



80/20 BRONZE LIGHT

EJ11
(See page 11)



PRO•ARTÉ NYLON CORE NORMAL TENSION

EJ45
(See page 12)



CLASSIC NYLON NORMAL TENSION

EJ27N
(See page 12)



MANDOLIN MEDIUM LOOP END

EJ74
(See page 17)



PRO•ARTÉ CUSTOM EXTRUDED SOPRANO UKULELE

EJ65S
(See page 17)

ELECTRIC GUITAR SETS



NYXL Nickel Round Wound

D'Addario NYXL guitar strings bend further, sing louder, and stay in tune better than any string you've played before. Envisioned, perfected, and manufactured by D'Addario in New York, this newly engineered, break-resistant, high-carbon steel core and plain steel alloy deliver a whole new level of freedom, confidence, and power.

STANDARD GAUGE

Item #	Scale	Gauge	Retail
NYXL0838	Extra Super Light	.008-.038	\$21.60
NYXL0942	Super Light	.009-.042	\$21.60
NYXL0946	Super Light Top / Regular Bottom	.009-.046	\$21.60
NYXL1046	Regular Light	.010-.046	\$21.60
NYXL1052	Light Top / Heavy Bottom	.010-.052	\$22.70
NYXL1149	Medium	.011-.049	\$21.60

HEAVY GAUGE

Item #	Scale	Gauge	Retail
NYXL1152	Medium Top / Heavy Bottom	.011-.052	\$22.70
NYXL1156	Medium Top / Extra Heavy Bottom	.011-.056	\$22.70
NYXL1254	Heavy	.012-.054	\$22.70
NYXL1260	Extra Heavy	.012-.060	\$22.70

BALANCED TENSION

Item #	Scale	Gauge	Retail
NYXL0940BT	Super Light	.009-.040	\$21.60
NYXL1046BT	Regular Light	.010-.046	\$21.60
NYXL1150BT	Medium	.011-.050	\$21.60

WOUND THIRD

Item #	Scale	Gauge	Retail
NYXL1252W	Light Wound Third	.012-.052	\$24.60
NYXL1356W	Medium Wound Third	.013-.056	\$24.60

EXTENDED RANGE

Item #	Scale	Gauge	Retail
NYXL1059	Regular Light 7-string	.010-.059	\$26.50
NYXL1164	Medium 7-string	.011-.064	\$26.50
NYXL0980	Super Light 8-string	.009-.080	\$32.80
NYXL1074	Light Top / Heavy Bottom 8-string	.010-.074	\$32.80

HALF GAUGE

Item #	Scale	Gauge	Retail
NYXL09544	Super Light Plus	.0095-.044	\$21.60

STEINBERGER DOUBLE BALL END

Item #	Scale	Gauge	Retail
NEW! NYXLS0942	Super Light Double Ball End	.009-.042	\$55.45
NEW! NYXLS1046	Regular Light Double Ball End	.010-.046	\$55.45

PEDAL STEEL GUITAR

Item #	Scale	Gauge	Retail
NEW! NYXL1138PS	Regular Light / E-9th Pedal Steel Tuning	.011-.038	\$30.00
NEW! NYXL1238PS	Custom Medium / E-9th Pedal Steel Tuning	.012-.038	\$30.00
NEW! NYXL1270PS	Custom Medium / C-6th Pedal Steel Tuning	.012-.070	\$38.15



XL™ Nickel Round Wound

XL Nickel Wound™ are precision wound with nickel-plated steel onto a carefully drawn, hexagonally shaped, high-carbon steel core. The result is strings with long lasting, distinctively bright tone and excellent intonation, ideal for the widest variety of guitars and musical styles.

Item #	Scale	Gauge	Retail
EXL110	Regular Light	.010-.046	\$11.55
EXL110-7	Regular Light 7-string	.010-.059	\$14.95
EXL110W	Regular Light / Wound 3rd	.010-.046	\$12.60
EKXL110	Regular Light / Soldered Twists	.010-.046	\$15.45
ESXL110	Regular Light / Double Ball End	.010-.046	\$36.20
EXL110+	Regular Light Plus	.0105-.048	\$11.55
EXL115	Blues / Jazz Rock	.011-.049	\$11.55
EXL115W	Blues / Jazz Rock / Wound 3rd	.011-.049	\$12.60
EXL116	Medium Top / Heavy Bottom	.011-.052	\$12.60
EXL117	Medium Top / Extra Heavy Bottom	.011-.056	\$12.60
EXL120	Super Light	.009-.042	\$11.55
EXL120-7	Super Light 7-string	.009-.054	\$14.95
EXL120-8	Super Light 8-string	.009-.065	\$19.55
EKXL120	Super Light / Soldered Twists	.009-.042	\$15.45
ESXL120	Super Light / Double Ball End	.009-.042	\$36.20
EXL120+	Super Light Plus	.0095-.044	\$11.55
EXL125	Super Light Top / Regular Bottom	.009-.046	\$11.55
ESXL125	Super Light Top / Regular Bottom / Double Ball End	.009-.046	\$36.20
EXL130	Extra-Super Light	.008-.038	\$11.55
EXL130+	Extra-Super Light Plus	.0085-.039	\$11.55
EXL140	Light Top / Heavy Bottom	.010-.052	\$12.60
EXL140-8	Light Top / Heavy Bottom	.010-.074	\$23.60
EXL145	Heavy	.012-.054	\$12.60
EXL148	Extra Heavy	.012-.060	\$12.60
EXL150	Super Light / 12-string	.010-.046	\$18.10
EXL150H	High-Strung / Nashville Tuning	.010-.026	\$8.50
EJ20	Jazz Extra Light	.010-.049	\$13.80
EJ21	Jazz Light	.012-.052	\$13.80
EJ22	Jazz Medium	.013-.056	\$13.80
EXL157	Baritone Medium	.014-.068	\$18.60
EXL158	Baritone Light	.013-.062	\$17.60
EXL156	Electric Guitar / Bass-Fender Bass VI	.024-.084	\$30.15



Gorgeous strings. I use them all the time.
Nile Rodgers



XL™ Balanced Tension

D'Addario Balanced Tension guitar sets are comprised of mathematically optimized string gauge combinations, resulting in greater control and playing comfort. Combined with the distinctively bright tone of XL Nickel Wound strings, each set offers greater dynamic control and a more consistent feel between strings for evenly balanced bending, strumming, and picking.

Item #	Scale	Gauge	Retail
EXL110BT	Regular Light	.010-.046	\$11.55
EXL115BT	Medium	.011-.050	\$11.55
EXL120BT	Super Light	.009-.040	\$11.55



EXP™ Nickel Round Wound

D'Addario EXPs are the longest-lasting, most natural-sounding coated strings available. EXP Coated Technology starts with the highest quality nickel-plated steel wrap wire, precision drawn and micro-coated on our advanced proprietary machinery. Strings are then wound normally on our proprietary NY Steel core, delivering tone and feel identical to uncoated strings, and improving tuning stability and break strength. With a minimum of 4 times more life, you won't believe they are coated!

Item #	Scale	Gauge	Retail
EXP110	Regular Light	.010-.046	\$23.30
EXP115	Blues / Jazz Rock	.011-.049	\$23.30
EXP120	Super Light	.009-.042	\$23.30
EXP125	Super Light Top / Regular Bottom	.009-.046	\$23.30
EXP140	Light Top / Heavy Bottom	.010-.052	\$23.30



These strings and my custom James Trussart are the perfect match!
Lucinda Williams



XL™ ProSteels Round Wound

ProSteels utilize a highly magnetic, corrosion-resistant steel alloy that delivers a super bright tone without shrill overtones. They offer a palette of harmonically rich, brilliantly penetrating highs combined with pronounced, tight-and-tough lows. If you're looking for more crunch, bite, and sustain, ProSteels are the choice for you.

Item #	Scale	Gauge	Retail
EPS510	Regular Light	.010-.046	\$12.80
EPS520	Super Light	.009-.042	\$12.80
EPS530	Extra-Super Light	.008-.038	\$12.80
EPS540	Light Top / Heavy Bottom	.010-.052	\$13.95
EPS515	Medium	.011-.050	\$12.80
EPS590	Jazz Light	.012-.052	\$15.35
EPS600	Jazz Medium	.013-.056	\$15.35
EPS490	E-9th Pedal Steel Tuning	.013-.038	\$21.75
EPS500	C-6th Pedal Steel Tuning	.012-.070	\$27.70



I have been using D'Addario strings since the day I first picked up a guitar. To this day, they are the only strings I use.
Margo Price



XL™ Half Rounds

Half Rounds are round wound with stainless steel and then precision ground to leave the outer surface smooth and semi-flat. The result is tone and tension characteristics of round wound strings with a smoother feel similar to flat wound strings.

Item #	Scale	Gauge	Retail
EHR310	Regular Light	.010-.046	\$20.35
EHR320	Super Light	.009-.042	\$20.35
EHR330	Extra-Super Light	.008-.039	\$20.35
EHR340	Light Top / Heavy Bottom	.010-.052	\$20.35
EHR370	Medium	.011-.049	\$20.35
EHR350	Jazz Light	.012-.052	\$23.95
EHR360	Jazz Medium	.013-.056	\$23.95

ACOUSTIC & ELECTRIC GUITAR SETS



XL™ Pure Nickel Round Wound

D'Addario XL Pure Nickel strings look back to the '50s, when nickel was the primary alloy found in electric guitar strings. Pure nickel strings would be supplanted by nickel-plated steel in the '60s, when guitarists required brighter tone and enhanced magnetism. Pure Nickel brings back the richer, warmer timbres found in traditional blues, classic rock, rockabilly, and more.

Item #	Scale	Gauge	Retail
EPN110	Regular Light	.010-.045	\$16.40
EPN115	Blues / Jazz Rock	.011-.048	\$16.40
EPN120	Super Light	.009-.041	\$16.40
EPN21	Jazz Light	.012-.051	\$18.50
EPN22	Jazz Medium	.013-.055	\$18.50

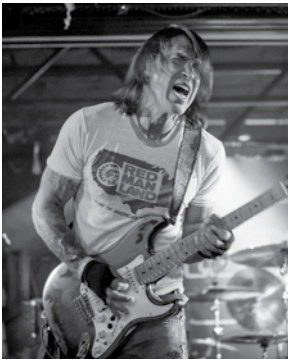

I'm an old-school tone guy. I prefer nickel on nickel; nickel strings on nickel frets. I like to feel that grind and resistance.

George Lynch

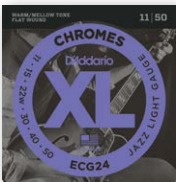

XL™ Chromes Flat Wound

D'Addario Chromes are the world's most popular flat wound strings. Chromes are wound with flattened stainless steel ribbon wire polished to an incredibly smooth surface, delivering a distinctively damped but tone-rich sound that only flat wounds can produce.

Item #	Scale	Gauge	Retail
ECG23	Extra Light	.010-.048	\$34.95
ECG24	Jazz Light	.011-.050	\$34.95
ECG24-7	Jazz Light / 7-string	.011-.065	\$45.55
ECG25	Light	.012-.052	\$34.95
ECG26	Medium	.013-.056	\$34.95



You know how guitar strings sound best when they are just about to break? Well these don't break cause they sound like that fresh out of the bag! Dig it.

**Jimmy Vivino,
Conan O'Brien**



Nickel Bronze

Nickel Bronze strings are the premium uncoated acoustic string by D'Addario. Featuring an innovative combination of nickel-plated phosphor bronze wrapped around a high-carbon NY steel core, these strings bring out the unique tonal characteristics of any guitar, allowing its natural voice to truly shine. Nickel

Bronze strings deliver enhanced projection, articulation and resonance, all with improved tuning stability and increased break resistance.

Item #	Scale	Gauge	Retail
NB1047	Extra Light	.010-.047	\$18.50
NB1152	Custom Light	.011-.052	\$18.50
NEW! NB1252BT	Light / Balanced Tension	.012-.052	\$18.50
NB1253	Light	.012-.053	\$18.50
NB1256	Light Top / Medium Bottom	.012-.056	\$18.50
NB1356	Medium	.013-.056	\$18.50
NEW! NB13556BT	Medium / Balanced Tension	.0135-.056	\$18.50
NB1656	Resophonic Guitar	.016-.056	\$18.50
NB1047-12	Light / 12-string	.010-.047	\$29.10



D'Addario's Nickel Bronze strings have brought new life back into my guitar. The tone is balanced, organic and punchy. These are the strings to beat.

Richard On, O.A.R.

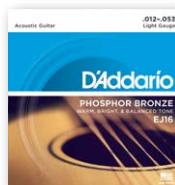

Phosphor Bronze Round Wound

D'Addario introduced Phosphor Bronze to string making in 1974, and it has become synonymous with warm, bright, and well-balanced acoustic tone. They are precision wound with corrosion-resistant phosphor bronze onto a carefully drawn, hexagonally shaped, high-carbon steel core, resulting in long-lasting, bright-sounding tone with excellent intonation.

Item #	Scale	Gauge	Retail
EJ15	Extra Light	.010-.047	\$14.25
EJ26	Custom Light	.011-.052	\$14.25
EJ16	Light	.012-.053	\$14.25
EJ19	Bluegrass Light Top / Medium Bottom	.012-.056	\$14.25
EJ17	Medium	.013-.056	\$14.25
EJ24	True Medium / DADGAD Tuning	.013-.056	\$14.25
EJ18	Heavy	.014-.059	\$14.25
EJ41	Extra Light / 12-string	.009-.045	\$22.45
EJ38	Light / 12-string	.010-.047	\$22.45
EJ38H	High-Strung / Nashville Tuning	.010-.027	\$10.20
EJ39	Medium / 12-string	.012-.052	\$22.45
EJ37	Medium Top / Heavy Bottom / 12-string	.012-.054	\$24.45
EJ42	Resophonic Guitar	.016-.056	\$14.25



EXP™ Coated Phosphor Bronze

D'Addario's proprietary EXP Coated Phosphor Bronze strings feature plain strings and hexagonal cores made of our revolutionary high-carbon NY Steel. Forged, drawn, and coated to deliver unprecedented strength and pitch stability, each EXP set maintains that familiar uncoated tone with a minimum of 4 times more life. You won't believe they are coated!

Item #	Scale	Gauge	Retail
EXP15	Extra Light	.010-.047	\$26.95
EXP26	Custom Light	.011-.052	\$26.95
EXP16	Light	.012-.053	\$26.95
EXP19	Bluegrass	.012-.056	\$26.95
EXP17	Medium	.013-.056	\$26.95
EXP42	Resophonic Guitar	.016-.056	\$26.95
EXP38	Light / 12-string	.010-.047	\$44.60
EXP23	Baritone	.016-.070	\$31.10



80/20 Bronze Round Wound

Commonly referred to as brass, 80/20 Bronze is the original acoustic string alloy selected by John D'Addario Sr. and John D'Angelico in the 1930s. 80/20 Bronze strings are popular for recording due to their crisp, deep, and projecting tone, and they appeal to many traditionalists and vintage enthusiasts for their historical significance. All D'Addario acoustic strings are wound on a hexagonally shaped, high-carbon steel core, resulting in long-lasting, bright-sounding tone with excellent intonation.

Item #	Scale	Gauge	Retail
EJ10	Extra Light	.010-.047	\$11.25
EJ13	Custom Light	.011-.052	\$11.25
EJ11	Light	.012-.053	\$11.25
EJ12	Medium	.013-.056	\$11.25
EJ14	Bluegrass Light Top / Medium Bottom	.012-.056	\$11.25
EJ36	Light / 12-string	.010-.047	\$17.80



EXP™ Coated 80/20 Bronze

D'Addario's proprietary EXP Coated 80/20 strings now feature plain strings and hexagonal cores made of our revolutionary high-carbon NY Steel. Forged, drawn, and coated to deliver unprecedented strength and pitch stability, each EXP set maintains that familiar uncoated tone with a minimum of 4 times more life. You won't believe they are coated!

Item #	Scale	Gauge	Retail
EXP10	Extra Light	.010-.047	\$24.80
EXP13	Custom Light	.011-.052	\$24.80
EXP11	80/20 Light	.012-.053	\$24.80
EXP12	Medium	.013-.056	\$24.80
EXP36	12-string	.010-.047	\$39.20
EXP14	Bluegrass	.012-.056	\$24.80

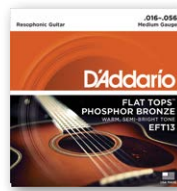

Flat Tops Phosphor Bronze

Flat Tops are round wound then precision ground, leaving the outer surface smooth and semi-flat. This produces a smooth, flattened playing surface, without sacrificing the superb tone and sustain associated with phosphor bronze strings. Flat Tops greatly reduce finger noise and are excellent for recording and flat-picking.

Item #	Scale	Gauge	Retail
EFT13	Resophonic Guitar	.016-.056	\$31.60
EFT15	Extra Light	.010-.047	\$31.60
EFT16	Regular Light	.012-.053	\$31.60
EFT17	Medium	.013-.056	\$31.60



Gypsy Jazz

D'Addario Gypsy Jazz strings are specially designed for the "Django" style. Silver-plated copper is wound on a high-carbon steel core, delivering a warm, projecting tone that is optimal for any Gypsy Jazz style guitar.

Item #	Scale	Gauge	Retail
EJ83L	Ball End Light	.010-.044	\$18.35
EJ83M	Ball End Medium	.011-.045	\$18.35
EJ84L	Loop End Light	.010-.044	\$18.35
EJ84M	Loop End Medium	.011-.045	\$18.35



Silk & Steel Folk Guitar

D'Addario Silk & Steel strings couple silver-plated copper wrap wire with silk for easy fingering and a mellow tone. They are excellent for smaller body acoustic guitars and preferred by many folk players.

Item #	Scale	Gauge	Retail
EJ35	Silver-plated Wound / 12-string	.011-.047	\$28.75
EJ40	Silver-plated Wound	.011-.047	\$22.15

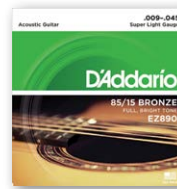

85/15 Great American Bronze

Great American bronze strings combine the brilliance of 80/20 alloy strings with the great sustain and long-lasting characteristics of phosphor bronze.

Item #	Scale	Gauge	Retail
EZ890	Super Light	.009-.045	\$9.55
EZ900	Extra Light	.010-.050	\$9.55
EZ910	Light	.011-.052	\$9.55
EZ920	Medium Light	.012-.054	\$9.55
EZ930	Medium	.013-.056	\$9.55
EZ940	12-Strings/Light	.010-.050	\$15.80

CLASSICAL GUITAR SETS



Pro-Arté™ Nylon Core

Each Pro-Arté string is sorted by a sophisticated, computer-controlled laser machine which performs diameter / tension measurements and quality checks to ensure true-sounding, precise trebles in every set. Pro-Arté basses are wound using silver-plated copper on a multifilament nylon core for a consistent, warm and projecting tone.

Item #	Scale	Retail
EJ44C	Long-Lasting Composite - Extra Hard	\$30.45
EJ44	Silver / Clear - Extra Hard	\$20.15
EJ44LP	Lightly Polished Silver / Clear - Extra Hard	\$45.95
EJ45C	Long-Lasting Composite - Normal	\$30.45
EJ45	Silver / Clear - Normal	\$20.15
EJ45LP	Lightly Polished Silver / Clear - Normal	\$45.95
EJ46C	Long-Lasting Composite - Hard	\$30.45
EJ46	Silver / Clear - Hard	\$20.15
EJ46LP	Lightly Polished Silver / Clear - Hard	\$45.95
EJ43	Silver / Clear - Light	\$20.15
EJ47	80/20 Bronze / Clear - Normal	\$20.15
EJ48	80/20 Bronze / Clear - Hard	\$20.15
EJ49	Silver / Black - Normal	\$20.15
EJ50	Silver / Black - Hard	\$20.15
EJ51	Semi-Polished Silver - Hard	\$62.65
EJ52	Alto Guitar Silver / Clear - Normal	\$18.60
EJ25B	Composite Flamenco / Black - Normal	\$23.60
EJ25C	Composite Flamenco / Clear - Normal	\$23.60



Pro-Arté™ Carbon Classical

Experience the vibrant, projecting, contemporary tone of Pro-Arté Carbon strings. Featuring our fluorocarbon trebles, these strings are designed for unsurpassed intonation, contemporary projecting tone, and responsive attack. Pro-Arté Carbons are paired with our Dynacore basses, constructed using our exclusive multifilament stranded core material with a revolutionary winding technique.

our exclusive multifilament stranded core material with a revolutionary winding technique.

Item #	Scale	Retail
EJ45FF	Composite / Carbon - Normal	\$34.90
EJ46FF	Composite / Carbon - Hard	\$34.90



Pro-Arté™ Dynacore

Pro-Arté Dynacore sets are constructed using our exclusive multifilament stranded core material with a revolutionary winding technique. The result is a rich, round and full tone with dramatically improved string life, tuning stability and consistency. These basses are complimented by bright and projecting titanium trebles for optimal tonal balance.

Item #	Scale	Retail
EJ44TT	Composite / Titanium - Extra Hard	\$32.60
EJ45TT	Composite / Titanium - Normal	\$32.60
EJ46TT	Composite / Titanium - Hard	\$32.60



EXP™ Classical

Our revolutionary micro-fine EXP coating is applied to the silver-plated copper wrap wire *before* winding. This exclusive coating process delivers a transparent tone and natural feel for strings that last at least 4 times longer. Combined with our precision laser-selected nylon trebles, EXPs are the ultimate classical strings.

Item #	Scale	Retail
EXP44	Silver - Extra Hard	\$24.75
EXP45	Silver - Normal	\$24.75
EXP46	Silver - Hard	\$24.75



Pro-Arté™ Rectified

Each set includes our precision rectified nylon trebles, ground using our proprietary centerless grinding technique. Roundness and dimension-control are unsurpassed, ensuring absolutely perfect intonation. Rectified sets are known for their warmer, mellower tone and slightly textured feel.

Item #	Scale	Retail
EJ29	Silver / Rectified Clear Nylon - Moderate	\$20.15
EJ30	Silver / Rectified Clear Nylon - Normal	\$20.15
EJ31	Silver / Rectified Clear Nylon - Hard	\$20.15



Folk Nylon

D'Addario Folk Nylon strings are constructed with high-quality nylon and a ball end on each string to facilitate easy installation on classical or steel string acoustic guitars.

Item #	Scale	Retail
EJ32C	Silver / Clear Nylon	\$20.75
EJ32	Silver / Black Nylon	\$20.75
EJ33	80/20 Bronze / Clear Nylon	\$20.75
EJ34	80/20 Bronze / Black Nylon	\$20.75

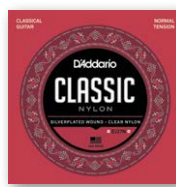

D'Addario Student Classics

D'Addario Student Classics are great for beginners, students and professionals. Each set contains 3 clear nylon trebles and 3 silver-plated copper wound basses for the optimal balance of warm and projecting, long-lasting tone.

Item #	Scale	Retail
EJ27N	Silver / Clear Nylon / Student - Normal	\$13.55
EJ27H	Silver / Clear Nylon / Student - Hard	\$13.55
EJ27N 3/4	Silver / Clear Nylon / 3 / 4 Guitar - Normal	\$13.55
EJ27N 1/2	Silver / Clear Nylon / 1 / 2 Guitar - Normal	\$13.55



Classical Half Sets

D'Addario Half Sets provide flexibility for each player to customize their own sound and feel. Choose from a wide range of material combinations to create the voice of your instrument. Each set contains 3 treble or bass strings in a convenient, resealable pouch.

Treble Half Sets

PRO-ARTÉ CLEAR NYLON

Item #	Scale	Retail
CNA-3T	Alto	\$6.00
CNL-3T	Light	\$6.00
CNN-3T	Normal	\$6.00
CNH-3T	Hard	\$6.00
CNX-3T	Extra Hard	\$6.00

PRO-ARTÉ CLEAR NYLON WITH COMPOSITE 3RD/G

Item #	Scale	Retail
CGN-3T	Normal	\$10.55
CGH-3T	Hard	\$10.55
CGX-3T	Extra Hard	\$10.55

PRO-ARTÉ BLACK NYLON

Item #	Scale	Retail
BNN-3T	Normal	\$6.00
BNH-3T	Hard	\$6.00

PRO-ARTÉ RECTIFIED NYLON

Item #	Scale	Retail
RNM-3T	Moderate	\$7.55
RNN-3T	Normal	\$7.55
RNH-3T	Hard	\$7.55

PRO-ARTÉ T2 TITANIUM NYLON

Item #	Scale	Retail
TNN-3T	Normal	\$10.05
TNH-3T	Hard	\$10.05
TNX-3T	Extra Hard	\$10.05

PRO-ARTÉ CARBON

Item #	Scale	Retail
CBN-3T	Normal	\$12.55
CBH-3T	Hard	\$12.55

PRO-ARTÉ HYBRID CARBON

Item #	Scale	Retail
HGN-3T	Carbon G, Clear Nylon B / E - Normal	\$8.20
HBN-3T	Carbon G / B, Clear Nylon E - Normal	\$10.40
HGH-3T	Carbon G, Clear Nylon B / E - Hard	\$8.20
HBH-3T	Carbon G / B, Clear Nylon E - Hard	\$10.40

Bass Half Sets

SILVER-PLATED COPPER ON NYLON CORE

Item #	Scale	Retail
SNA-3B	Alto	\$14.75
SNL-3B	Light	\$14.75
SNN-3B	Normal	\$14.75
SNH-3B	Hard	\$14.75
SNX-3B	Extra Hard	\$14.75

SILVER-PLATED COPPER ON COMPOSITE CORE

Item #	Scale	Retail
SCN-3B	Normal	\$18.10
SCH-3B	Hard	\$18.10
SCX-3B	Extra Hard	\$18.10
SCF-3B	Flamenco	\$18.10

LIGHTLY POLISHED SILVER ON COMPOSITE CORE

Item #	Scale	Retail
LCN-3B	Normal	\$35.10
LCH-3B	Hard	\$35.10
LCX-3B	Extra Hard	\$35.10

EXP SILVER-PLATED COPPER ON COMPOSITE CORE

Item #	Scale	Retail
XCN-3B	Normal	\$22.00
XCH-3B	Hard	\$22.00
XCX-3B	Extra Hard	\$22.00

SEMI-POLISHED SILVER-PLATED COPPER ON COMPOSITE CORE

Item #	Scale	Retail
PCH-3B	Hard	\$53.50

80/20 BRONZE ON NYLON CORE

Item #	Scale	Retail
BNN-3B	Normal	\$14.75
BNH-3B	Hard	\$14.75

SILVER ON COMPOSITE DYNACORE

Item #	Scale	Retail
SDN-3B	Normal	\$23.80
SDH-3B	Hard	\$23.80
SDX-3B	Extra Hard	\$23.80

BASS GUITAR SETS



NYXL Bass

NYXL Bass features our high-carbon NY Steel core wrapped with our reformulated nickel-plated steel. This new construction delivers deep, powerful lows, focused punch, and accentuated harmonics. Designed for all playing styles, NYXL Bass provides more dynamic range and sustain than any other electric bass string.

Item #	Scale	Gauge	Retail
NYXL4095	Long	.040 .060 .075 .095	\$55.45
NYXL45100	Long	.045 .065 .080 .100	\$55.45
NYXL45105	Long	.045 .065 .085 .105	\$55.45
NYXL50105	Long	.050 .070 .085 .105	\$55.45
NYXL55110	Long	.055 .075 .090 .110	\$55.45
NYXL45125	Long / 5-string	.045 .065 .085 .105 .125	\$68.40
NYXL45130	Long / 5-string	.045 .065 .080 .100 .130	\$68.40
NYXL32130	Long / 6-string	.032 .045 .065 .080 .130	\$72.55
NYXL45100SL	Super Long	.045 .065 .080 .100	\$63.65
NYXL45130SL	Super Long / 5-string	.045 .065 .080 .100 .130	\$72.55
NYXL32130SL	Super Long / 6-string	.032 .045 .065 .080 .100 .130	\$79.50



NYXLs exceeded my expectations. After putting my first set on my jazz, and warming my fingers up with them, I got lost in my head for a second from just really enjoying the feeling and tone I was getting. Then I realized it was from the change I had made in strings, and I was immediately sold.

Royal Masat

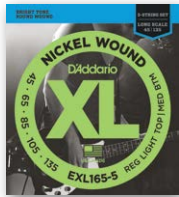

XL™ Nickel Round Wound

XL Nickel Round Wound electric bass strings are precision wound on our exclusive computer-controlled machines, ensuring each string has excellent intonation, clear fundamentals, and unparalleled consistency. Each string is wound with a nickel-plated steel wrap wire known for a distinctive, bright tone with excellent magnetic output, delivering a universally appealing and versatile tone for all playing styles.

Item #	Scale	Gauge	Retail
EXL160	Long	.050 .070 .085 .105	\$40.35
EXL160SL	Super Long	.050 .070 .085 .105	\$44.85
EXL160S	Short	.050 .070 .085 .105	\$40.35
EXL160M	Medium	.050 .070 .085 .105	\$40.35
EXL160-5	Long / 5-string	.050 .070 .085 .105 .135	\$52.60
ESXL160	Double Ball / Medium	.050 .070 .085 .105	\$88.85
EXL165	Long	.045 .065 .085 .105	\$40.35
EXL165SL	Super Long	.045 .065 .085 .105	\$44.85
EXL165-5	Long / 5-string	.045 .065 .085 .105 .135	\$52.60
EXL165-6	Long / 6-string	.032 .045 .065 .085 .105 .135	\$58.25
ESXL165	Double Ball	.045 .065 .085 .105	\$88.85
EXL170	Long	.045 .065 .080 .100	\$40.35
ESXL170-5	Double Ball / 5-string	.045 .065 .080 .100 .130	\$118.75
EXL170SL	Super Long	.045 .065 .080 .100	\$44.85
EXL170S	Short	.045 .065 .080 .100	\$40.35
EXL170M	Medium	.045 .065 .080 .100	\$40.35
EXL170-5	Long / 5-string	.045 .065 .080 .100 .130	\$52.60
EXL170-5SL	Super Long / 5-string	.045 .065 .080 .100 .130	\$58.25
EXL170-6	Long / 6-string	.032 .045 .065 .080 .100 .130	\$58.25

Item #	Scale	Gauge	Retail
EXL170-8	Long / 8-string	.018 .028 .040 .050 .045 .065 .080 .100	\$66.20
EXL170-12	Long / 12-string	.018(2) .025(2) .035(2) .045 .065 .080 .100 .45(2)	\$77.00
ESXL170	Double Ball / Light	.045 .065 .080 .100	\$88.85
EXL180	Long	.035 .055 .075 .095	\$40.35
EXL190	Long	.040 .060 .080 .100	\$40.35
EXL220	Long	.040 .060 .075 .095	\$40.35
EXL220SL	Super Long	.040 .060 .075 .095	\$44.85
EXL220S	Short	.040 .060 .075 .095	\$40.35
EXL220M	Medium	.040 .060 .075 .095	\$40.35
EXL220-5	Long / 5-string	.040 .060 .075 .095 .125	\$52.60
EXL230	Long	.055 .075 .090 .110	\$40.35
EXL280	Piccolo	.020 .032 .042 .052	\$33.60

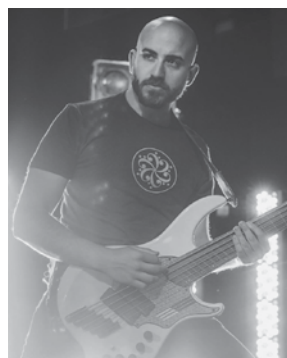

Nickel wounds have the character that all bass strings must be measured by: bright, clear, snappy yet also full and completely consistent from set to set. I never have to adjust my setup and intonation when changing strings, they just work and sound great every time!

**Adam Nolly Getgood,
Periphery**

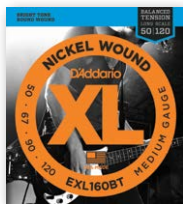

XL™ Balanced Tension

D'Addario Balanced Tension bass sets are comprised of mathematically optimized string gauge combinations, resulting in greater control and playing comfort. Combined with the distinctively bright tone of XL Nickel Wound strings, each set offers greater dynamic control and a more consistent feel between strings for evenly

balanced plucking, slapping, and bending.

Item #	Scale	Gauge	Retail
EXL160BT	Long	.050 .067 .090 .120	\$42.25
EXL170BT	Long	.045 .060 .080 .107	\$42.25
EXL220BT	Long	.040 .055 .070 .095	\$42.25



I've been using D'Addario XLs for over two decades and depend on their tone, feel, and consistency. They are essential to my sound.

Adam Nitti



EXP™ Coated Nickel Round Wound

D'Addario EXPs deliver the longest-lasting, most natural-sounding coated strings available. EXP Coated Technology starts with the highest quality wrap wire materials, precision drawn and micro-coated on our advanced proprietary machinery. Strings are then

wound normally, delivering tone and feel identical to D'Addario's world-renowned XL line of bass strings with a minimum of 4 times more life.

Item #	Scale	Gauge	Retail
EXP160	Long	.050 .070 .085 .105	\$58.75
EXP165	Long	.045 .065 .085 .105	\$58.75
EXP170	Long	.045 .065 .080 .100	\$58.75
EXP170SL	Super Long	.045 .065 .080 .100	\$63.60
EXP170-5	Long / 5-string	.045 .065 .080 .100 .130	\$68.60
EXP170-5SL	Super Long / 5-string	.045 .065 .080 .100 .130	\$73.40
EXP220	Long	.040 .060 .075 .095	\$58.75



XL™ ProSteels Round Wound

ProSteels are D'Addario's brightest and most magnetic bass strings. A specialized steel alloy delivers harmonically rich, brilliant high-end, coupled with deep, tight lows that work in tandem to create the coveted "piano tone" steel players crave. Great for both articulate fingering or aggressive picking,

ProSteels give you the extra edge and punch you need to cut through the mix.

Item #	Scale	Gauge	Retail
EPS160	Long	.050 .070 .085 .105	\$40.25
EPS160-5	Long / 5-string	.050 .070 .085 .105 .135	\$53.70
EPS160SL	Super Long	.050 .070 .085 .105	\$44.75
EPS165	Long	.045 .065 .085 .105	\$40.25
EPS165-5	Long / 5-string	.045 .065 .085 .105 .135	\$53.70
EPS165SL	Super Long	.045 .065 .085 .105	\$44.65
EPS170	Long	.045 .065 .080 .100	\$40.25
EPS170-5	Long / 5-string	.045 .065 .080 .100 .130	\$53.70
EPS170-6	Long / 6-string	.030 .045 .065 .080 .100 .130	\$58.15
EPS170M	Medium	.045 .065 .080 .100	\$40.25
EPS170S	Short	.045 .065 .080 .100	\$40.25
EPS170SL	Super Long	.045 .065 .080 .100	\$44.65
EPS170-5SL	Super Long / 5-string	.045 .065 .080 .100 .130	\$58.15
EPS170-6SL	Super Long / 6-string	.030 .045 .065 .080 .100 .130	\$63.70
EPS180	Long	.035 .055 .075 .095	\$40.25
EPS190	Long	.040 .060 .080 .100	\$40.25
EPS220	Long	.040 .060 .075 .095	\$40.25
EPS220-5	Long / 5-string	.040 .060 .075 .095 .125	\$53.70
EPS230	Long	.055 .075 .090 .110	\$40.25
EPS300	Tapered Long	.043 .060 .085 .107	\$40.25
EPS300-5	Tapered Long / 5-string	.043 .060 .085 .107 .130	\$53.70



I've used D'Addario stainless steel strings for over 20 years, because they deliver the best quality strings... they're always great right out of the box, and I go through a LOT of strings. They just rock!

Bryan Beller

BASS GUITAR SETS



XL™ Nylon Tapewound

Designed to produce a deep, warm tone with a smooth feel, D'Addario Tapewound bass strings are wound using flattened black nylon polished to an ultra-smooth finish. These long-lasting, well-balanced strings are expertly engineered to provide optimal tension, and are gauged to fit properly on standard bass saddles and

nuts. Tapewounds may be used on fretted or fretless basses, and are designed to deliver a vintage tone ranging from the thump of an upright bass to the focused depth of traditional flat wound strings.

Item #	Scale	Gauge	Retail
ETB92	Long	.050 .065 .085 .105	\$93.10
ETB92S	Short	.050 .065 .085 .105	\$93.10
ETB92M	Medium	.050 .065 .085 .105	\$93.10
ETB92-5	Long / 5-string	.050 .065 .085 .105 .135	\$119.75
ETB92SL	Super Long	.050 .065 .085 .105	\$106.45

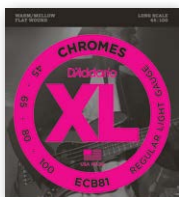

XL™ Chromes Flat Wound

Complex combinations of interlocking underwindings on a hex core build a foundation for the delicate outer ribbon winding. After winding, each string is polished to produce an incredibly smooth surface.

Item #	Scale	Gauge	Retail
ECB80	Long	.040 .060 .075 .095	\$82.50
ECB80SL	Super Long	.040 .060 .075 .095	\$94.90
ECB84	Long	.040 .060 .080 .100	\$82.50
ECB81	Long	.045 .065 .080 .100	\$82.50
ECB81S	Short	.045 .065 .080 .100	\$82.50
ECB81M	Medium	.045 .065 .080 .100	\$82.50
ECB81SL	Super Long	.045 .065 .080 .100	\$94.90
ECB81-5	Long / 5-string	.045 .065 .080 .100 .132	\$116.15
ECB81-5SL	Super Long / 5-string	.045 .065 .080 .100 .132	\$129.85
ECB82	Long	.050 .070 .085 .105	\$82.50



We were working on *Evil Urges* when our producer suggested using D'Addario strings. Slapped them on our guitars and never looked back. Perfect tension and tone.

**Tom Blankenship,
My Morning Jacket**



XL™ Half Rounds

D'Addario Half Round bass strings are wound with pure nickel then precision ground, leaving the outer surface smooth and semi-flat while retaining the flexibility of round wound strings. D'Addario's exclusive heat treating process ensures that Half Rounds retain their round wound brightness and sustain.

Item #	Scale	Gauge	Retail
ENR70	Long	.040 .060 .075 .095	\$63.70
ENR71	Long	.045 .065 .080 .100	\$63.70
ENR71SL	Super Long	.045 .065 .080 .100	\$72.85
ENR71S	Short	.045 .065 .080 .100	\$63.70
ENR71M	Medium	.045 .065 .080 .100	\$63.70
ENR71-5	Long / 5-string	.045 .065 .080 .100 .130	\$88.05
ENR71-5SL	Super Long / 5-string	.045 .065 .080 .100 .130	\$95.10
ENR71-6	Long / 6-string	.030 .045 .065 .080 .100 .130	\$95.10
ENR72	Long	.050 .070 .085 .105	\$63.70
ENR73	Long	.055 .075 .090 .110	\$63.70



Great clarity, long durability and helps to create pure tone.
Bill Laswell



Phosphor Bronze Acoustic Bass

Phosphor Bronze is popular in the acoustic market for its resilient tone and boomy bass, while affording players a smooth, consistent surface for picking or plucking. Also available in EXP Coated, and a set specially designed for Taylor GS Mini Bass.

Item #	Scale	Gauge	Retail
EXPPBB170	Coated / Long	.045 .065 .080 .100	\$78.30
EPBB170	Long	.045 .065 .080 .100	\$52.45
EPBB170-5	Long / 5-string	.045 .065 .080 .100 .130	\$64.90
EXPPBB170S	Coated / Short	.045 .065 .080 .100	\$78.30
EXPPBB170-5	Coated / 5-string / Long	.045 .065 .080 .100 .130	\$92.00
EXPPBB190GS	Coated / Taylor GS Mini	.037 .050 .062 .090	\$73.95



Nickel Bronze Mandolin

Nickel Bronze strings are the premium uncoated mandolin strings by D'Addario. Featuring an innovative combination of nickel-plated phosphor bronze wrapped onto a high-carbon NY Steel core, these loop end strings bring out the unique tonal characteristics of any mandolin, allowing its natural voice to truly shine. Nickel Bronze delivers unrivaled clarity, resonance and projection, as well as outstanding balance and harmonically rich overtones. Players will also enjoy improved tuning stability and higher break resistance, thanks to D'Addario-engineered NY Steel cores and plain steel strings.

Item #	Scale	Retail
NBM1038	Light	\$19.75
NBM1140	Medium	\$19.75
NBM11540	Custom Medium	\$19.75
NBM11541	Medium / Heavy	\$19.75



EXP™ Coated Mandolin

Phosphor Bronze & 80/20 Bronze

D'Addario's proprietary EXP Coated strings now feature plain strings and hexagonal cores made of our revolutionary high-carbon NY Steel. Forged, drawn, and coated to deliver unprecedented strength and pitch stability, each EXP set maintains that familiar uncoated tone with a minimum of 4 times more life. You won't believe they are coated!

Item #	Scale	Retail
EXP74	Phosphor Bronze - Medium	\$26.95
EXP74CM	Phosphor Bronze - Custom Medium	\$26.95
EXP75	Phosphor Bronze - Medium / Heavy	\$26.95
EXP77	80/20 Bronze - Medium	\$24.80



Mandolin

D'Addario mandolin strings are trusted for their natural acoustic tone and reliable performance by legends like David Grisman, Ricky Skaggs, Ronnie McCoury, Doyle Lawson, Rhonda Vincent, Mike Marshall, Adam Steffey, and more. They are made from the highest quality plain steel, stainless steel, nickel-plated steel, and phosphor bronze, available in a wide variety of gauges.

Item #	Scale	Retail
EJ62	80/20 Bronze	\$14.65
EJ67	Nickel	\$14.60
EJ70	Ball End / Phosphor Bronze - Medium / Light	\$15.40
EJ73	Phosphor Bronze - Light	\$14.95
EJ74	Phosphor Bronze - Medium	\$14.95
EJS74	Stainless Steel - Medium	\$14.60
EFT74	Flat Tops / Phosphor Bronze	\$40.15
EJ75	Phosphor Bronze - Medium / Heavy	\$14.95
EFW74	Flat Wound / Medium	\$32.50
EJ80	Octave Mandolin / Phosphor Bronze	\$21.55
EJ76	Mandola / Phosphor Bronze	\$21.55
EJ72	Mandola / Phosphor Bronze - Light	\$21.55
EFT76	Mandola / Flat Tops / Phosphor Bronze	\$56.10
EJ78	Mandocello / Phosphor Bronze	\$37.20
EJ79	Mandobass / Copper Coated Steel	\$54.95



Banjo

D'Addario banjo strings are made from the highest quality high-carbon steel and wrap materials, available in a wide variety of gauges. NY Steel banjo sets feature plain strings and hexagonal cores made of our revolutionary steel, forged and drawn to deliver unprecedented strength and pitch stability.

Item #	Scale	Retail
EJ60	Light / Nickel / 5-string	\$8.80
EJS60	Light / Stainless Steel / 5-string	\$9.70
EJ61	Medium / Nickel / 5-string	\$8.80
EJ63	Tenor Banjo / Nickel	\$8.80
EJ63i	Tenor Banjo-Irish / Nickel	\$8.80
EJ69	Light / Phosphor Bronze / 5-string	\$8.80
EJ55	Medium / Phosphor Bronze / 5-string	\$8.80
EJ57	Custom Medium / Nickel / 5-string	\$8.80
EJS57	Medium / Stainless Steel / 5-string	\$9.70
EJ60+	Light Plus / Nickel / 5-string	\$8.80
EJ69B	Ball End / Phosphor Bronze / 5-string	\$8.80
EJ60NY	Light / NY Steel Nickel / 5-string	\$17.05
EJ61NY	Medium / NY Steel Nickel / 5-string	\$17.05



Pro-Arté™ Custom Extruded Ukulele

Each Custom Extruded Ukulele set is manufactured on D'Addario's advanced monofilament extrusion line built exclusively for the production of musical instrument strings. Each set features our exclusive laser-sorted Pro-Arté clear nylon trebles for unsurpassed intonation and a warm, projecting acoustic tone.

Item #	Scale	Retail
EJ65S	Soprano Ukulele	\$9.80
EJ65C	Concert Ukulele	\$9.80
EJ65T	Tenor Ukulele	\$9.80
EJ65B	Baritone Ukulele	\$12.15
EJ65TLG	Tenor Low G Ukulele	\$10.65



Pro-Arté™ Titanium Ukulele

Pro-Arté Titanium Ukulele strings are crafted from a dense monofilament material that has an attractive, translucent purple hue and a polished, smooth feel. These sets have a brighter tone and increased projection compared to standard nylon, resulting in greater volume, clarity and dynamics.

Item #	Scale	Retail
EJ87S	Soprano	\$9.65
EJ87T	Tenor	\$10.15
EJ87C	Concert	\$9.65
EJ87B	Baritone	\$11.50

OTHER SETS



Pro-Arté™ Carbon Ukulele

Pro-Arté Carbon Ukulele strings are designed for the perfect blend of tone and projection. These fluorocarbon sets are ideal for progressive ukulele players looking for a bright, modern sound.

Item #	Scale	Retail
EJ99SC	Concert / Soprano	\$16.50
EJ99T	Tenor	\$16.50
EJ99B	Baritone	\$19.80
EJ99TLG	Tenor Low G	\$16.50



D'Addario strings are like steroids for the ukulele!
Jake Shimabukuro



Pro-Arté™ Rectified Black Nylon Ukulele

The original ukulele offering from D'Addario, each black nylon string is carefully center-less ground to an ultra-smooth, ultra-precise final diameter for excellent feel and unparalleled intonation with a warm, long-lasting acoustic tone.

Item #	Scale	Retail
EJ53S	Soprano	\$9.80
EJ53T	Nylon Tenor	\$10.65
EJ53C	Nylon Concert	\$9.80
EJ53B	Nylon Baritone	\$12.15



Nyltech Ukulele

Developed in cooperation with Aquila, D'Addario Nyltech Ukulele strings are an exclusive combination of materials designed to deliver an optimal combination of warm yet punchy tone, comfortable playability, precise intonation and tuning stability not found in other ukulele strings.

Item #	Scale	Retail
EJ88S	Soprano	\$12.95
EJ88T	Tenor	\$14.65
EJ88C	Concert	\$12.95
EJ88B	Baritone	\$16.20
EJ88UB	Bass	\$27.60



Special Sets: Dulcimer, Viola Brasileira, Bajo Sexto, Oud, Bouzouki, Cuatro, Lyra, & more

D'Addario offers a diverse selection of fretted instrument strings precisely engineered for optimal performance.

Item #	Scale	Retail
EJ64	Dulcimer / 4-string	\$7.20
EJ66	Tenor Guitar	\$8.05
EJ82A	Viola Brasileira Cebolão Ré and Boiadeira	\$15.60
EJ82B	Viola Brasileira Rio Abaixo and Meia Guitarra	\$15.60
EJ82C	Viola Brasileira Cebolão Mi and Boiadeira	\$15.60
EJ85	Bajo Quinto	\$33.90
EJ86	Bajo Sexto	\$45.20
EJ93	Cavaquinho	\$8.50
EJ94	Requinto	\$16.00
EJ95	Oud / 11-string	\$28.45
EJ95A	Arabic Oud / 11-string	\$28.45
EJ96	Cuatro-Puerto Rico	\$30.75
EJ97	Bouzouki-Greek	\$13.60
EJ81	Bouzouki-Irish	\$14.80
EJ98	Cuatro-Venezuela	\$6.85
EJ97-6	Bouzouki-Greek / 6-string	\$11.20
EJ91	Baglama-Tzouras / 6-string	\$10.40
EJ89	Cretan Lyra	\$23.20



D'Addario mandolin strings have long been the standard bearer of tone and playability.
Chris Thile



Chinese Traditional Instruments

To address the widespread need for professional quality accessories for Chinese traditional instruments, D'Addario teamed up with performers and educators around the world. Pairing their expert musicianship and advice with our experience in string making, we are able to create strings for these unique instruments with the

exceptional tone and precision that D'Addario is known for. Made in New York using our advanced string manufacturing equipment, D'Addario strings for traditional Chinese instruments deliver a world-class musical experience.

Item #	Scale	Gauge	Retail
ERHU01	Medium Tension	.010-.018	\$18.45



Electric Multi-Packs

D'Addario multi-packs are one box of 3 or 10 complete sets for guitar, and twin packs for bass, conveniently packaged and individually sealed in corrosion-resistant packaging. Individual sets not for resale.

D'Addario's convenient Bulk Shop boxes deliver easy access to 25 complete sets of D'Addario guitar strings at bulk-rate pricing.

Item #	Scale	Gauge	Retail
NYXL 3-Packs - Save 7%			
NYXL0942-3P	Super Light	.009 - .042	\$60.25
NYXL1046-3P	Regular Light	.010 - .046	\$60.25
NYXL1149-3P	Medium	.011 - .049	\$60.25

Item #	Scale	Gauge	Retail
XL 3-Packs - Save 7%			
EXL110-3D	Regular Light	.010-.046	\$32.20
EXL115-3D	Blues / Jazz Rock	.011-.049	\$32.20
EXL120-3D	Super Light	.009-.042	\$32.20
EXL125-3D	Super Light Top / Regular Bottom	.009-.046	\$32.20
EXL140-3D	Light Top / Heavy Bottom	.010-.052	\$35.15

Item #	Scale	Gauge	Retail
XL 10-Packs - Save 10%			
EXL110-10P	Regular Light	.010-.046	\$103.85
EXL115-10P	Blues / Jazz Rock	.011-.049	\$103.85
EXL120-10P	Super Light	.009-.042	\$103.85
EXL125-10P	Super Light Top / Regular Bottom	.009-.046	\$103.85
EXL140-10P	Light Top / Heavy Bottom	.010-.052	\$113.30

Item #	Scale	Gauge	Retail
XL Bulk Shop 25-Packs - Save 20%			
EXL110-B25	Regular Light	.010-.046	\$230.80
EXL115-B25	Blues / Jazz Rock	.011-.049	\$230.80
EXL120-B25	Super Light	.009-.042	\$230.80

Item #	Scale	Gauge	Retail
XL Bass Twin Packs - Save 10%			
EXL160TP	Long	.050 .070 .085 .105	\$76.15
EXL165TP	Long	.045 .065 .085 .105	\$76.15
EXL170TP	Long	.045 .065 .080 .100	\$76.15
EXL170-5TP	Long	.045 .065 .080 .100 .130	\$99.15
EXL220TP	Long	.040 .060 .075 .095	\$76.15

Acoustic & Classical Multi-Packs

Item #	Scale	Gauge	Retail
Phosphor Bronze 3-Packs - Save 7%			
EJ15-3D	Extra Light	.010-.047	\$39.75
EJ16-3D	Light	.012-.053	\$39.75
EJ17-3D	Medium	.013-.056	\$39.75
EJ26-3D	Custom Light	.011-.052	\$39.75

Item #	Scale	Gauge	Retail
80/20 Bronze 3-Packs - Save 7%			
NEW! EJ11-3D	Light	.012-.053	\$31.40
NEW! EJ12-3D	Medium	.013-.056	\$31.40
NEW! EJ13-3D	Custom Light	.011-.052	\$31.40

Item #	Scale	Gauge	Retail
EXP Phosphor Bronze 3-Packs - Save 7%			
NEW! EXP16-3D	Light	.012-.053	\$75.15
NEW! EXP17-3D	Medium	.013-.056	\$75.15
NEW! EXP26-3D	Custom Light	.011-.052	\$75.15

Item #	Scale	Gauge	Retail
Phosphor Bronze Mandolin 3-Packs - Save 7%			
EJ74-3D	Medium		\$41.65

Item #	Scale	Gauge	Retail
Phosphor Bronze 10-Packs - Save 10%			
EJ16-10P	Light	.012-.053	\$128.15
EJ17-10P	Medium	.013-.056	\$128.15
EJ26-10P	Custom Light	.011-.052	\$128.15

Item #	Scale	Gauge	Retail
Acoustic Bulk Shop 25-Packs - Save 20%			
EJ16-B25	Phosphor Bronze Light	.012-.053	\$284.75
EJ17-B25	Phosphor Bronze Medium	.013-.056	\$284.75
EXP11-B25	EXP 80/20 Bronze Light	.012-.053	\$495.50
EXP12-B25	EXP 80/20 Bronze Medium	.013-.056	\$495.50
EXP16-B25	EXP Phosphor Bronze Light	.012-.053	\$538.75
EXP26-B25	EXP Phosphor Bronze Custom Light	.011-.052	\$538.75

Item #	Scale	Retail
Classical 3-Packs - Save 7%		
EJ45-3D	Pro-Arte Silver / Clear - Normal	\$56.15
EJ46-3D	Pro-Arte Silver / Clear - Hard	\$56.15
NEW! EJ27N-3D	Student Synthetic Silver/Clear Nylon/Student - Normal	\$37.70

SINGLE STRINGS

Singles must be ordered in minimum quantities of 5 for plain steel and wound guitar strings and 1 for bass strings.

Acoustic / Electric Plain Steel



PL007	\$1.60
PL008	\$1.60
PL0085	\$1.60
PL009	\$1.60
PL0095	\$1.60
PL010	\$1.60
PL0105	\$1.60
PL011	\$1.60
PL0115	\$1.60
PL012	\$1.60
PL013	\$1.60
PL0135	\$1.60
PL014	\$1.60
PL015	\$1.60
PL016	\$1.60
PL017	\$1.60
PL018	\$1.60
PL019	\$1.65
PL020	\$1.65
PL022	\$1.65
PL024	\$1.65
PL026	\$1.65

Acoustic / Electric Steinberger™



SPL009	\$5.80
SPL010	\$5.80
SPL011	\$5.80
SPL013	\$5.80
SPL016	\$5.80
SPL017	\$5.80

Acoustic / Electric Reinforced Soldered Twists Plain Steel

KPL008	\$3.25
KPL009	\$3.25
KPL010	\$3.25
KPL011	\$3.25
KPL012	\$3.25
KPL013	\$3.25

KPL014	\$3.25
KPL015	\$3.25
KPL016	\$3.25
KPL017	\$3.25
KPL020	\$3.25

Acoustic / Electric NYXL High-Carbon Steel



NYS007	\$2.55
NYS008	\$2.55
NYS0085	\$2.55
NYS009	\$2.55
NYS0095	\$2.55
NYS010	\$2.55
NYS0105	\$2.55
NYS011	\$2.55
NYS0115	\$2.55
NYS012	\$2.55
NYS013	\$2.55
NYS0135	\$2.55
NYS014	\$2.55
NYS015	\$2.55
NYS016	\$2.55
NYS017	\$2.55
NYS018	\$2.55
NYS019	\$2.70
NYS020	\$2.70
NYS022	\$2.70
NYS024	\$2.70
NYS026	\$2.70

Acoustic / Electric XL™ Nickel Round Wound



NW017	\$2.95
NW018	\$2.95
NW019	\$2.95
NW020	\$2.95
NW021	\$2.95
NW022	\$2.95

NW024	\$2.95
NW025	\$2.95
NW026	\$2.95
NW028	\$3.10
NW030	\$3.10
NW032	\$3.10
NW034	\$3.10
NW036	\$3.10
NW037	\$3.60
NW038	\$3.60
NW039	\$3.60
NW040	\$3.60
NW042	\$3.60
NW044	\$3.60
NW046	\$3.60
NW048	\$3.60
NW049	\$3.60
NW050	\$3.60
NW052	\$4.25
NW054	\$4.25
NW056	\$4.25
NW059	\$4.25
NW060	\$4.25
NW062	\$5.30
NW064	\$5.30
NW066	\$5.30
NW068	\$6.55
NW070	\$6.55
NW072	\$6.55
NW074	\$6.55
NW080	\$9.80

Electric Guitar NYXL Round Wound



NYNW017	\$5.30
NYNW018	\$5.30
NYNW019	\$5.30
NYNW020	\$5.30
NYNW021	\$5.30
NYNW022	\$5.30
NYNW023	\$5.30
NYNW024	\$5.30
NYNW025	\$5.30
NYNW026	\$5.30
NYNW028	\$5.60
NYNW029	\$5.60
NYNW030	\$5.60

NYNW031	\$5.60
NYNW032	\$5.60
NYNW033	\$5.60
NYNW034	\$5.60
NYNW035	\$5.60
NYNW036	\$5.60
NYNW037	\$6.40
NYNW038	\$6.40
NYNW039	\$6.40
NYNW040	\$6.40
NYNW042	\$6.40
NYNW043	\$6.40
NYNW044	\$6.40
NYNW045	\$6.40
NYNW046	\$6.40
NYNW047	\$6.40
NYNW048	\$6.40
NYNW049	\$6.40
NYNW050	\$6.40
NYNW052	\$7.65
NYNW053	\$7.65
NYNW054	\$7.65
NYNW056	\$7.65
NYNW057	\$7.65
NYNW058	\$7.65
NYNW059	\$7.65
NYNW060	\$7.65
NYNW062	\$10.05
NYNW063	\$10.05
NYNW064	\$10.05
NYNW065	\$10.05
NYNW066	\$10.05
NYNW068	\$11.85
NYNW070	\$11.85
NYNW072	\$11.85
NYNW074	\$11.85
NYNW076	\$11.85
NYNW078	\$17.90
NYNW080	\$17.90

Electric Guitar Pure Nickel Round Wound

PNG023	\$4.30
PNG025	\$4.30
PNG027	\$4.30
PNG031	\$4.45
PNG035	\$4.45
PNG037	\$4.45
PNG041	\$5.00
PNG045	\$5.00
PNG048	\$5.00

Electric Guitar Chromes™ Flat Wound



CG020	\$8.00
CG022	\$8.00
CG024	\$8.00
CG026	\$8.60
CG028	\$9.00
CG030	\$9.00
CG032	\$9.00
CG035	\$9.00
CG038	\$9.00
CG040	\$9.00
CG042	\$9.00
CG045	\$9.80
CG048	\$9.80
CG050	\$9.80
CG052	\$9.80
CG056	\$11.15
CG065	\$13.60
CG075	\$13.60
CG080	\$13.60

Electric Guitar ProSteels™ Round Wound

PSG020	\$2.80
PSG021	\$2.80
PSG022	\$2.80
PSG024	\$2.80
PSG026	\$2.80
PSG028	\$2.95
PSG030	\$2.95
PSG032	\$2.95
PSG034	\$2.95
PSG036	\$2.95
PSG038	\$3.45
PSG040	\$3.45
PSG042	\$3.45
PSG046	\$3.45
PSG048	\$3.45
PSG050	\$4.05
PSG052	\$4.05
PSG054	\$4.05
PSG056	\$4.05
PSG070	\$6.25

Singles must be ordered in minimum quantities of 5 for plain steel and wound guitar strings and 1 for bass strings.

Acoustic Guitar
80/20 Bronze
Round Wound



BW020	\$2.80
BW021	\$2.80
BW022	\$2.80
BW023	\$2.80
BW024	\$2.80
BW025	\$2.80
BW026	\$2.80
BW027	\$2.80
BW029	\$3.15
BW030	\$3.15
BW032	\$3.15
BW034	\$3.15
BW035	\$3.15
BW036	\$3.15
BW039	\$3.15
BW042	\$3.15
BW045	\$3.15
BW047	\$3.15
BW049	\$3.50
BW052	\$3.50
BW053	\$3.50
BW056	\$3.50
BW059	\$3.50

Acoustic Guitar
Nickel Bronze



NB020	\$3.95
NB021	\$3.95
NB022	\$3.95
NB023	\$3.95
NB024	\$3.95
NB025	\$3.95
NB026	\$3.95
NB027	\$3.95
NB029	\$4.95
NB030	\$4.95
NB032	\$4.95
NB034	\$4.95

NB035	\$4.95
NB036	\$4.95
NB039	\$4.95
NB042	\$4.95
NB045	\$4.95
NB047	\$4.95
NB052	\$5.55
NB053	\$5.55
NB054	\$5.55
NB056	\$5.55
NB059	\$5.55
NB060	\$5.55

Acoustic Guitar
Phosphor Bronze
Round



PB017	\$3.00
PB020	\$3.00
PB021	\$3.00
PB022	\$3.00
PB023	\$3.00
PB024	\$3.00
PB025	\$3.00
PB026	\$3.00
PB027	\$3.00
PB028	\$3.80
PB029	\$3.80
PB030	\$3.80
PB032	\$3.80
PB034	\$3.80
PB035	\$3.80
PB036	\$3.80
PB039	\$3.80
PB042	\$3.80
PB045	\$3.80
PB047	\$3.80
PB049	\$4.20
PB052	\$4.20
PB053	\$4.20
PB054	\$4.20
PB056	\$4.20
PB059	\$4.20
PB060	\$4.20
PB062	\$4.70
PB064	\$4.70
PB066	\$4.70
PB070	\$7.80

Acoustic Guitar
Semi-Flat
Phosphor Bronze



FT023	\$6.75
FT024	\$6.75
FT026	\$6.75
FT028	\$7.55
FT030	\$7.55
FT032	\$7.55
FT035	\$7.55
FT036	\$7.55
FT039	\$8.25
FT042	\$8.25
FT044	\$8.25
FT045	\$8.25
FT047	\$8.25
FT053	\$8.90
FT056	\$8.90

Acoustic Guitar
EXP™ Coated 80/20
Bronze Round Wound

EXPBW020	\$4.85
EXPBW022	\$4.85
EXPBW023	\$4.85
EXPBW024	\$4.85
EXPBW025	\$4.85
EXPBW026	\$4.85
EXPBW027	\$4.85
EXPBW030	\$5.55
EXPBW032	\$5.55
EXPBW035	\$5.55
EXPBW036	\$5.55
EXPBW039	\$6.10
EXPBW042	\$6.10
EXPBW045	\$6.10
EXPBW047	\$6.10
EXPBW052	\$6.70
EXPBW053	\$6.70
EXPBW056	\$6.70
EXPBW059	\$6.70

Acoustic Guitar
EXP™ Coated Phosphor
Bronze Round Wound



EXPPB020	\$5.85
EXPPB022	\$5.85
EXPPB023	\$5.85
EXPPB024	\$5.85
EXPPB025	\$5.85
EXPPB026	\$5.85
EXPPB027	\$5.85
EXPPB028	\$6.40
EXPPB029	\$6.40
EXPPB030	\$6.40
EXPPB032	\$6.40
EXPPB034	\$6.40
EXPPB035	\$6.40
EXPPB036	\$6.40
EXPPB039	\$6.90
EXPPB042	\$6.90
EXPPB045	\$6.90
EXPPB047	\$6.90
EXPPB048	\$6.90
EXPPB052	\$7.45
EXPPB053	\$7.45
EXPPB056	\$7.45
EXPPB059	\$7.45
EXPPB060	\$7.45
EXPPB070	\$11.70

Classical Guitar



J4301 / E-1st	\$2.00
J4302 / B-2nd	\$2.10
J4303 / G-3rd	\$2.25
J4304 / D-4th	\$4.45
J4305 / A-5th	\$5.35
J4306 / E-6th	\$5.80
J4401 / E-1st	\$2.00
J4402 / B-2nd	\$2.10
J4403 / G-3rd	\$2.25
J4404 / D-4th	\$4.45
J4405 / A-5th	\$5.35
J4406 / E-6th	\$5.80
J4501 / E-1st	\$2.00
J4502 / B-2nd	\$2.10
J4503 / G-3rd	\$2.25
J4504 / D-4th	\$4.45
J4505 / A-5th	\$5.35
J4506 / E-6th	\$5.80
J4601 / E-1st	\$2.00
J4602 / B-2nd	\$2.10
J4603 / G-3rd	\$2.25
J4604 / D-4th	\$4.45
J4605 / A-5th	\$5.35
J4606 / E-6th	\$5.80
J4704 / D-4th	\$4.45
J4705 / A-5th	\$5.35
J4706 / E-6th	\$5.80

Classical Guitar

T2 Titanium Trebles	
T4401 / E-1st	\$3.30
T4402 / B-2nd	\$3.60
T4403 / G-3rd	\$3.85
T4501 / E-1st	\$3.30
T4502 / B-2nd	\$3.60
T4503 / G-3rd	\$3.85
T4601 / E-1st	\$3.30
T4602 / B-2nd	\$3.60
T4603 / G-3rd	\$3.85

SINGLE STRINGS

Singles must be ordered in minimum quantities of 5 for plain steel and wound guitar strings and 1 for bass strings.

Classical Guitar EXP™ Classical



EXP4404 / D-4th	\$6.60
EXP4405 / A-5th	\$7.40
EXP4406 / E-6th	\$8.40
EXP4504 / D-4th	\$6.60
EXP4505 / A-5th	\$7.40
EXP4506 / E-6th	\$8.40
EXP4604 / D-4th	\$6.60
EXP4605 / A-5th	\$7.40
EXP4606 / E-6th	\$8.40

Classical Guitar Pro•Arté™ Composites

J4403C / G-3rd	\$7.10
J4404C / D-4th	\$6.50
J4405C / A-5th	\$6.50
J4406C / E-6th	\$6.50
J4503C / G-3rd	\$7.10
J4504C / D-4th	\$6.50
J4505C / A-5th	\$6.50
J4506C / E-6th	\$6.50
J4603C / G-3rd	\$7.10
J4604C / D-4th	\$6.50
J4605C / A-5th	\$6.50
J4606C / E-6th	\$6.50

Classical Guitar Pro•Arté™

J4504LP / D-4th	\$12.40
J4505LP / A-5th	\$12.40
J4506LP / E-6th	\$12.40
J4604LP / D-4th	\$12.40
J4605LP / A-5th	\$12.40
J4606LP / E-6th	\$12.40

Classical Guitar Rectified



J2901 / E-1st	\$2.60
J2902 / B-2nd	\$2.70
J2903 / G-3rd	\$2.80
J2904 / D-4th	\$4.30
J2905 / A-5th	\$4.40
J2906 / E-6th	\$5.30
J3001 / E-1st	\$2.60
J3002 / B-2nd	\$2.70
J3003 / G-3rd	\$2.80
J3004 / D-4th	\$4.30
J3005 / A-5th	\$4.75
J3006 / E-6th	\$5.30
J3101 / E-1st	\$2.60
J3102 / B-2nd	\$2.70
J3103 / G-3rd	\$2.80
J3104 / D-4th	\$4.30
J3105 / A-5th	\$4.75
J3106 / E-6th	\$5.30

Classic Nylon



J2701	\$1.55
J2702	\$1.85
J2703	\$1.95
J2704	\$3.70
J2705	\$3.85
J2706	\$4.15
J27H01	\$1.55
J27H02	\$1.85
J27H03	\$1.95
J27H04	\$3.70
J27H05	\$3.85
J27H06	\$4.15

Classical Guitar Rectified Nylon



NYL018	\$2.60
NYL019	\$2.60
NYL020	\$2.60
NYL021	\$2.60
NYL022	\$2.60
NYL024	\$2.60
NYL027	\$2.60
NYL028	\$2.60
NYL029	\$2.75
NYL030	\$2.75
NYL031	\$2.80
NYL032	\$2.80
NYL033	\$2.80
NYL034	\$2.80
NYL038	\$2.90
NYL039	\$2.90
NYL040	\$2.90

Classical Guitar

Silver-plated Wound

NYL019w	\$4.75
NYL020w	\$4.75
NYL022w	\$4.75
NYL024w	\$4.75
NYL025w	\$4.75
NYL026w	\$4.75
NYL028w	\$4.75
NYL029w	\$4.75
NYL030w	\$4.75
NYL031w	\$4.75
NYL033w	\$4.75
NYL034w	\$4.75
NYL035w	\$4.75
NYL036w	\$4.75
NYL040w	\$5.35
NYL041w	\$5.35
NYL043w	\$5.35
NYL045w	\$5.35
NYL048w	\$5.35
NYL050w	\$7.45
NYL052w	\$7.45
NYL054w	\$7.45
NYL056w	\$7.45
NYL058w	\$7.45
NYL060w	\$7.45

Folk Guitar Ball End Nylon



BEC028	\$2.60
BEC032	\$2.90
BEC040	\$3.10
BEB028	\$2.60
BEB032	\$2.90
BEB040	\$3.10
BEB031w	\$4.35
BEB037w	\$4.50
BEB045w	\$4.85
BES031w	\$4.90
BES037w	\$5.10
BES045w	\$5.50

BASS SINGLES

Electric Bass

XL™ Nickel Wound Long Scale	
XLB018p	\$5.35
XLB020p	\$7.00
XLB025w	\$7.65
XLB028w	\$7.65
XLB032	\$8.65
XLB035	\$8.65
XLB040	\$8.65
XLB042	\$8.65
XLB045	\$8.65
XLB050	\$8.65
XLB052	\$8.65
XLB055	\$8.65
XLB060	\$10.45
XLB065	\$10.45
XLB067	\$10.45
XLB070	\$10.45
XLB075	\$11.15
XLB080	\$11.15
XLB085	\$11.15
XLB090	\$13.45
XLB095	\$13.45
XLB100	\$13.45
XLB105	\$13.45
XLB107	\$13.45
XLB110	\$13.45
XLB120	\$14.95
XLB125	\$14.95
XLB130	\$14.95
XLB135	\$14.95
XLB145	\$14.95
XLB160	\$17.25

Electric Bass

XL™ Nickel Wound Super Long Scale	
XB040SL	\$9.85
XB045SL	\$9.85
XB050SL	\$9.85
XB060SL	\$11.70
XB065SL	\$11.70
XB070SL	\$11.70
XB075SL	\$11.70
XB080SL	\$12.40
XB085SL	\$12.40
XB090SL	\$14.65
XB095SL	\$14.65
XB100SL	\$14.65
XB105SL	\$14.65
XB110SL	\$14.65
XB125SL	\$16.15
XB130SL	\$16.15
XB145SL	\$16.15

XL™ Nickel Wound Medium Scale

XB040M	\$8.65
XB045M	\$8.65
XB050M	\$8.65
XB060M	\$10.45
XB065M	\$10.45
XB070M	\$10.45
XB075M	\$11.15
XB080M	\$11.15
XB085M	\$11.15
XB095M	\$13.45
XB100M	\$13.45
XB105M	\$13.45

XL™ Nickel Wound Short Scale

XB045S	\$8.65
XB050S	\$8.65
XB065S	\$10.45
XB070S	\$10.45
XB080S	\$11.15
XB085S	\$11.15
XB100S	\$13.45
XB105S	\$13.45

XL™ Nickel Wound Tapered Long Scale

XLB120T	\$17.65
XLB125T	\$17.65
XLB130T	\$17.65
XLB135T	\$17.65
XLB145T	\$18.55
XLB160T	\$19.95
XLB165T	\$22.50
XLB170T	\$24.70

Singles must be ordered in minimum quantities of 5 for plain steel and wound guitar strings and 1 for bass strings.

Electric Bass

XL™ Nickel Wound Tapered Super Long Scale

XB125TSL	\$18.75
XB130TSL	\$18.75
XB145TSL	\$18.75
XB160TSL	\$21.45
XB165TSL	\$24.05
XB170TSL	\$26.55

Electric Bass

Steinberger™ Long Scale

SXL045	\$16.85
SXL050	\$16.85
SXL065	\$21.80
SXL070	\$21.80
SXL080	\$23.25
SXL085	\$23.25
SXL100	\$28.05
SXL105	\$28.05
SXL130	\$30.85

Electric Bass

NYXL Bass



NYXLB032	\$11.35
NYXLB040	\$11.35
NYXLB045	\$11.35
NYXLB050	\$11.35
NYXLB060	\$13.65
NYXLB065	\$13.65
NYXLB070	\$13.65
NYXLB075	\$14.55
NYXLB080	\$14.55
NYXLB085	\$14.55
NYXLB095	\$17.60
NYXLB100	\$17.60
NYXLB105	\$17.60
NYXLB125	\$19.60
NYXLB130	\$19.60
NYXLB135	\$21.30

NYXL Bass Super Long Scale

NYXLB100SL	\$19.25
NYXLB130SL	\$21.30

Electric Bass

NYXL Tapered Long Scale

NYXLB085T	\$18.65
NYXLB095T	\$22.55
NYXLB100T	\$22.55
NYXLB0105T	\$22.55
NYXLB125T	\$23.20
NYXLB130T	\$23.20
NYXLB135T	\$24.80

NYXL Tapered Super Long Scale

NYXLB100TSL	\$26.15
NYXLB130TSL	\$26.85

Electric Bass

EXP™ Long Scale

EXPXLB032	\$11.35
EXPXLB035	\$12.40
EXPXLB040	\$12.40
EXPXLB045	\$12.40
EXPXLB050	\$12.40
EXPXLB060	\$12.40
EXPXLB065	\$16.00
EXPXLB070	\$16.00
EXPXLB075	\$16.00
EXPXLB080	\$16.00
EXPXLB085	\$16.00
EXPXLB095	\$19.35
EXPXLB100	\$19.35
EXPXLB105	\$19.35
EXPXLB125	\$21.45
EXPXLB130	\$21.45

EXP™ Super Long Scale

EXPXB045SL	\$13.50
EXPXB065SL	\$17.10
EXPXB080SL	\$17.10
EXPXB100SL	\$20.40
EXPXB130SL	\$22.65

Electric Bass

ProSteels™ Long Scale

PSB028w	\$7.10
PSB030	\$7.10
PSB032	\$7.10
PSB035	\$8.25
PSB040	\$8.25
PSB045	\$8.25
PSB050	\$8.25
PSB055	\$9.95
PSB060	\$9.95
PSB065	\$9.95
PSB070	\$9.95
PSB075	\$10.60
PSB080	\$10.60
PSB085	\$10.60
PSB090	\$12.80
PSB095	\$12.80
PSB100	\$12.80
PSB105	\$12.80
PSB110	\$12.80
PSB120	\$14.25
PSB125	\$14.25
PSB130	\$14.25
PSB135	\$15.40
PSB145	\$15.40

ProSteels™ Tapered Long Scale

PSB120T	\$16.80
PSB125T	\$16.80
PSB130T	\$16.80
PSB135T	\$16.80
PSB145T	\$17.65

ProSteels™ Super Long Scale

PSB030SL	\$8.70
PSB032SL	\$8.70
PSB035SL	\$8.70
PSB040SL	\$8.70
PSB045SL	\$9.40
PSB050SL	\$9.40
PSB060SL	\$11.15
PSB065SL	\$11.15
PSB070SL	\$11.15
PSB075SL	\$11.80
PSB080SL	\$11.80
PSB085SL	\$11.80
PSB090SL	\$13.40
PSB095SL	\$13.40
PSB100SL	\$13.40
PSB105SL	\$13.40
PSB110SL	\$13.40
PSB125SL	\$15.40
PSB130SL	\$16.20
PSB135SL	\$16.20

Electric Bass

ProSteels™ Tapered Super Long Scale

PSB125TSL	\$19.70
PSB130TSL	\$19.70
PSB135TSL	\$19.70
PSB145TSL	\$19.70

ProSteels™ Medium Scale

PSB045M	\$8.25
PSB065M	\$9.95
PSB080M	\$10.60
PSB100M	\$12.80

ProSteels™ Short Scale

PSB045S	\$8.25
PSB065S	\$9.95
PSB080S	\$10.60
PSB100S	\$12.80

Electric Bass

Half Round™ Nickel Long Scale

NHR030	\$9.75
NHR040	\$11.70
NHR045	\$11.70
NHR050	\$12.95
NHR055	\$12.95
NHR060	\$16.40
NHR065	\$16.40
NHR070	\$16.40
NHR075	\$18.20
NHR080	\$18.20
NHR085	\$18.20
NHR090	\$22.55
NHR095	\$22.55
NHR100	\$22.55
NHR105	\$22.55
NHR110	\$22.55
NHR130	\$26.45

Half Round™ Nickel Super Long Scale

NHR045SL	\$14.00
NHR065SL	\$18.70
NHR080SL	\$20.50
NHR100SL	\$24.90
NHR130SL	\$28.80

Half Round™ Nickel Medium Scale

NHR045M	\$11.70
NHR065M	\$16.40
NHR080M	\$18.20
NHR100M	\$22.55

Electric Bass

Half Round™ Nickel Short Scale

NHR045S	\$11.70
NHR065S	\$16.40
NHR080S	\$18.20
NHR100S	\$22.55

Half Round™ Nickel Tapered Long Scale

NHR130T	\$28.20
----------------	---------

Half Round™ Nickel Tapered Super Long Scale

NHR130TSL	\$30.50
------------------	---------

Electric Bass

Chromes™ Flat Wound Long Scale

CB032	\$16.55
CB040	\$17.65
CB045	\$17.65
CB050	\$17.65
CB055	\$19.75
CB060	\$19.75
CB065	\$20.30
CB070	\$20.30
CB075	\$23.00
CB080	\$23.00
CB085	\$23.00
CB090	\$23.00
CB095	\$27.05
CB100	\$27.05
CB105	\$27.05
CB110	\$27.05
CB132	\$42.40

Chromes™ Flat Wound Super Long Scale

CB040SL	\$20.30
CB045SL	\$20.30
CB060SL	\$22.40
CB065SL	\$25.70
CB075SL	\$25.70
CB080SL	\$25.70
CB095SL	\$29.75
CB100SL	\$29.75
CB132SL	\$44.95

SINGLE STRINGS

Singles must be ordered in min qty of 10 for loop end & mandolin, 5 for plain steel & wound guitar, and 1 for bass.

Electric Bass

XL™ Nylon Tapewound
Long Scale

TWB035	\$19.95
TWB050	\$20.35
TWB065	\$22.60
TWB085	\$29.85
TWB105	\$34.30
TWB135	\$40.60

XL™ Nylon Tapewound
Medium Scale

TWB050M	\$20.35
TWB065M	\$22.60
TWB085M	\$29.85
TWB105M	\$34.30

XL™ Nylon Tapewound
Short Scale

TWB050S	\$20.35
TWB065S	\$22.60
TWB085S	\$29.85
TWB105S	\$34.35

Acoustic Bass

Phosphor Bronze Wound
Long Scale

PBB045	\$10.00
PBB065	\$11.90
PBB080	\$13.00
PBB100	\$15.55
PBB130	\$18.05

Acoustic Bass

EXP™ Phosphor Bronze
Long Scale

EXPPBB045	\$15.65
EXPPBB065	\$18.50
EXPPBB080	\$20.65
EXPPBB100	\$25.55
EXPPBB130	\$27.65

MISC SINGLES

Loop End Strings
Plain Steel



LE008	\$1.95
LE009	\$1.95
LE0095	\$1.95
LE010	\$1.95
LE011	\$1.95
LE0115	\$1.95
LE012	\$1.95
LE013	\$1.95
LE014	\$1.95
LE015	\$1.95
LE016	\$1.95
LE017	\$1.95
LE018	\$1.95

Nickel Round Wound

LE018w	\$3.45
LE020w	\$3.45
LE022w	\$3.45
LE023w	\$3.45
LE024w	\$3.45
LE026w	\$3.45
LE028w	\$3.45
LE030w	\$3.45
LE032w	\$3.45
LE034w	\$3.45
LE036w	\$3.45
LE038w	\$3.45
LE040w	\$3.45
LE042w	\$4.05
LE044w	\$4.05
LE046w	\$4.05
LE048w	\$4.05
LE049w	\$4.05
LE052w	\$4.55
LE054w	\$4.55
LE056w	\$4.55
LE059w	\$4.55

Loop End Strings

Phosphor Bronze

LE018pb	\$3.70
LE020pb	\$3.70
LE022pb	\$3.70
LE023pb	\$3.70
LE024pb	\$3.70
LE026pb	\$3.70
LE028pb	\$3.70
LE030pb	\$3.70
LE032pb	\$3.70
LE034pb	\$3.80
LE036pb	\$3.80
LE038pb	\$3.80
LE040pb	\$3.80
LE042pb	\$4.75
LE045pb	\$4.75
LE046pb	\$4.75
LE047pb	\$4.75
LE049pb	\$4.75
LE052pb	\$4.75
LE053pb	\$4.75
LE056pb	\$4.75
LE059pb	\$4.75
LE062pb (Bajo)	\$4.75
LE078pb (Bajo)	\$7.95
LE092pb (Bajo)	\$8.60

Mandolin Family

Mandolin



J6201	\$1.65
J6202	\$1.65
J6203	\$2.90
J6204	\$2.90
J6701	\$1.65
J6702	\$1.65
J6703	\$3.00
J6704	\$3.00
J7401	\$1.65
J7402	\$1.65
J7403	\$3.00
J7404	\$3.00
J7501	\$1.65
J7502	\$1.65

Other

J6404	\$3.35
J6403	\$1.75
J6404	\$3.35
J9301	\$1.65
J9302	\$1.65

Ukulele Hawaiian

J5403	\$4.00
-------	--------

5-PACKS

Plain Steel



Save 10%	
PL009-5	\$7.10
PL010-5	\$7.10
PL011-5	\$7.10
PL012-5	\$7.10
PL013-5	\$7.10



Single String Kits

D'Addario's unique single string kits are guaranteed to improve the look, functionality, and profitability of single strings. These new boxes are designed to take up less space and include kit divider cards for easy viewing of string assortment. Additionally, they are modular so they can be locked together for a uniform, visually appealing presentation. Each kit assortment has been reconfigured for optimized sell-through at a lower price!

**Kit divider cards are available by request.
Contact your sales rep for details.**

1-800-268-6855 or orders@daddario.com

Single String Kits / Displays

Item #	Description	Retail
PL100	300 Plain Steel strings in gauges from .007-.026 for acoustic or electric guitars. Emphasis on more popular numbers. Includes half sizes.	\$329.80
NW100	Nickel Wound String Kit - 138 strings in gauges from .018-.059. Exact replacements for all wound strings in XL sets.	\$376.10
EG100	Combo Nickel Wound and Plain Steel Starter Kit - 183 guitar strings in gauges from .008-.020 plain steel and .018-.056 (XL) nickel wound.	\$336.45
PB100	Phosphor Bronze Wound String Kit - 130 wound strings for acoustic guitar in gauges from .020-.059.	\$361.85
AG100	Acoustic String Starter Kit - 146 guitar strings in gauges from .010-.018 plain steel and .022-.056 phosphor bronze wound.	\$286.45
XL255	XL Nickel Round Wound Bass Kit - 60 plain steel and nickel wound long scale electric bass strings. Perfect for custom gauge bass sets.	\$578.70
SRGE5	Empty wooden boxes for single guitar strings.	
SRBE3	Empty wooden boxes for single bass strings.	



D'Addario Brochure Rack

This wire frame holder attaches neatly onto any slatwall, EVUMS or JRUMS fixture to fit any of our branded gear or survival guide brochures.

Item # DD-WLH



BDE3



GDE3



**DD-SBTH5 (Guitar)
DD-SBTH6 (Bass)**

Spring-loaded String Set Wall Displays

Item #	Description	Retail
EXL30	30 sets of XL electric guitar strings: (15) EXL110 and (15) EXL120 contained in spring-loaded display.	\$343.80
EPA30	30 sets of Pro-Arté classical guitar strings: (15) EJ45 and (15) EJ46 contained in spring-loaded display.	\$599.70
EPB30	30 sets of Phosphor Bronze guitar strings: (15) EJ16 and (15) EJ17 contained in spring-loaded display.	\$425.00
EXLB15	15 sets of XL bass strings: (10) EXL170 and (5) EXL160 contained in spring-loaded display.	\$609.35
GDE3	D'Addario spring-loaded string displays – Guitar (7" L x 5" W x 11" H)	
BDE3	D'Addario spring-loaded string displays – Bass (7" L x 7" W x 14" H)	
DD-SBTH5	Price tag holder for GDE2-L spring-loaded guitar string displays Bass (7" L x 7" W x 14" H)	
DD-SBTH6	Price tag holder for BDE2-L spring-loaded bass string displays Bass (7" L x 7" W x 14" H)	

Junior UMS Floor Display

The Junior UMS is a compact solution ideal for any size retail store. Each of the existing display components may be applied to this UMS including string baskets, cable shelving, strap fixtures and slatwall hooks. Suggested assortments are available and may be customized to meet the particular needs of the retailer. 19.5"L x 20"W x 69.25"H

Item # **JRUMS**

Suggested Product Mix

Item #	Description	Qty
NYXL0838	NYXL Extra Super Light .008-.038	10
NYXL0942	NYXL Super Light .009-.042	10
NYXL0946	NYXL Super Light Top / Regular Bottom .009-.046	10
NYXL1046	NYXL Regular Light .010-.046	10
NYXL1149	NYXL Medium .011-.049	10
NYXL1052	NYXL Light Top / Heavy Bottom .010-.052	10
EXL110	XL Regular Light .010-.046	10
EXL110BT	XL Balanced Tension Regular Light .010-.046	10
EXL120	XL Super Light .009-.042	10
EXL120BT	XL Balanced Tension Super Light .009-.040	10
EXL115	XL Medium .011-.049	10
EXL140	XL Light Top / Heavy Bottom .010-.052	10
EXL170	XL Long .040-.100	5
EXL160	XL Long .050-.105	5
NYXL45100	NYXL Long .045-.100	5
NYXL45105	NYXL Long .045-.105	5

Item#	Description	Qty
NB1253	Nickel Bronze Light .012-.053	20
NB1356	Nickel Bronze Medium .013-.056	20
NB1152	Nickel Bronze Custom Light .011-.052	10
NB1047	Nickel Bronze Extra Light .010-.047	10
EXP16	EXP Coated Phosphor Bronze .012-.053	10
EJ16	Phosphor Bronze Light .012-.053	20
EXP17	EXP Coated Phosphor Bronze .013-.056	10
EJ17	Phosphor Bronze Medium .013-.056	20
EXP26	EXP Coated Phosphor Bronze .011-.052	10
EJ26	Phosphor Bronze Custom Light .011-.052	20
EJ45	Pro-Arte Silver / Clear / Normal	10
EJ46	Pro-Arte Silver / Clear / Hard	10
EJ44	Pro-Arte Silver / Clear / Extra Hard	10
EXP74CM	EXP Coated Mandolin Custom Medium	10
EJ74	Mandolin / Phosphor Bronze / Medium	10
EJ75	Mandolin / Phosphor Bronze / Med Heavy	10



JRUMS

ACCESSORIES



THE POWER OF INNOVATION

As musicians, it is our mission to create cutting-edge products that help fellow players perform with ease and focus on their sound. As innovators, we strive to bring exceptional products to the instrument accessory line, and 2018 is geared up to be another ground-breaking year for D'Addario Accessories.

First, we're adding to our custom cable options with the **DIY Pedalboard Power Cable Kit**. D'Addario custom cable kits are as simple as cutting the included cable to length, placing it into the plug end, and securing the set screw to produce flawless, custom-length power cables. The kit configures for straight or right-angle connections, and includes a cable tester to check for proper connection before installation. And to help power your amplifiers and effects, our new **Tour-Grade Power Cables** feature increased copper and robust IEC construction, while the **Power Cable +** includes an additional auxiliary outlet for powering your pedalboard or other accessories.



Although cradle-style capos are most popular among bluegrass and folk players, any musician can benefit from our new **Cradle Capo**. Quick and easy to position, this cradle-style capo centers behind the neck of your instrument automatically, assuring horizontal string-pull for perfect tuning and intonation while conveniently storing behind the nut when not in use.



And to round out our line of high-quality straps, we're catering to the growing ukulele market with our new **Ukulele Straps**. Combining strength, durability and elegance, these straps are precision crafted with top-of-the-line webbing made from recycled plastic bottles and an improved clasp that securely clips into the soundhole of the instrument. Now along with our capos, humidifiers, and picks, D'Addario has a complete line of ukulele accessories and instrument care.

As always, we are committed to providing you with world-class products so you can focus on making and enjoying the ultimate playing experience.

TOP SELLERS & MUST HAVES



NS MICRO HEADSTOCK TUNER

PW-CT-12
(see page 31)



CHROMATIC PEDAL TUNER

PW-CT-20
(see page 30)



PRO-WINDER

DP0002
(see page 42)



ECLIPSE TUNER

PW-CT-17RD
(see page 30)



NS CAPO PRO

PW-CP-02
(see page 36)



NS ARTIST CAPO

PW-CP-10
(see page 34)



HUMIDIPAK MAINTAIN KIT

PW-HPK-01
(see page 46)



HUMIDITRAK

PW-HTK-01
(see page 46)



SCREECHING HALT

PW-SH-01
(see page 49)



PEDALBOARD CABLE KIT

PW-GPKIT-10
(see page 96)



CLASSIC SERIES PATCH CABLE

PW-CGTP-305
(see page 90)



VARIGRIP

PW-VG-01
(see page 39)

TUNERS

TOP★SELLER

Eclipse Tuners

Eclipse chromatic clip-on tuners offer fast, accurate tuning on and off the stage. The tuner features a full-color vertical display, auto power-off, and pitch calibration in a discreet compact design. The dual-swivel action allows the perfect viewing angle and can be mounted in front or behind the headstock on right- and left-handed instruments. Available in multiple colors.

- Quick, Accurate Tuning
- Full-color display
- Dual 360° swivel points for limitless viewing angles



Item #	Description	Retail	Item #	Description	Retail
PW-CT-17BK	Black	\$21.50	PW-CT-17RD	Red	\$21.50
PW-CT-17YL	Yellow	\$21.50	PW-CT-17PR	Purple	\$21.50
PW-CT-17GN	Green	\$21.50	PW-CT-17BU	Blue	\$21.50
PW-CT-17MP	10-pack assorted colors: 5 black, 1 red, 1 blue, 1 yellow, 1 green, 1 purple				\$299.50

TOP★SELLER

NEW! Chromatic Pedal Tuner

The D'Addario Chromatic Pedal Tuner is the perfect combination of innovation, simplicity and style. Housed in a rugged aluminum enclosure, the tuner features fast note detection, superb accuracy, wide calibration range and true-bypass wiring with an easily accessible foot switch. The tuner's full-color vertical display allows for quick intuitive tuning at home, in the studio or onstage.

- 32-bit processor for fast response
- True-bypass wiring
- Full-color vertical display
- Slim, lightweight design



Item #	Retail
PW-CT-20	\$130.15

NS Micro Soundhole Tuner

Designed specifically for acoustic guitar, ukulele, and other acoustic instruments, the chromatic NS Micro Soundhole Tuner remains perfectly concealed within an instrument's soundhole for discreet tuning. The non-marring universal mounting clip allows stress-free installation, while the highly sensitive piezo transducer senses vibrations directly from the soundboard for fast and accurate tuning response. The bright, multi-color display allows easy viewing in any environment. It's so small, convenient, and accurate, you'll want one for every acoustic instrument you own!

- Multi-color display
- Non-marring soundhole clip
- Fast, accurate response
- Calibration range 410 - 480 Hz



Item #	Retail
PW-CT-15	\$33.50

NS Micro Banjo Tuner

Designed specifically for banjos, the chromatic NS Micro Banjo Tuner blends with the instrument's aesthetics for discreet tuning. The non-marring hoop mounting bracket allows for stress-free installation and the highly sensitive piezo transducer senses vibrations directly from the instrument for fast and accurate tuning response. The bright, multi-color display allows for easy viewing in any environment, and the tuner does not require removal when the instrument is stored.

- Fast, accurate response
- Non-marring hoop bracket
- Fits lug spacing from .80" - 1.75"
- Multi-color display
- Visual metronome

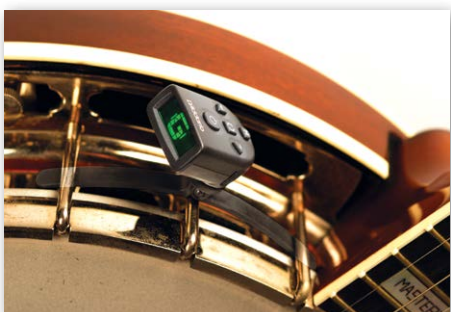

Item #	Retail
PW-CT-16	\$31.50

NEW! NS Clip-Free Tuner

The ultimate in discreet tuning, the NS Micro Clip-Free Tuner features a full-color display and metronome in a housing that blends with the aesthetics of any instrument. The included clip-free mount attaches directly to your instrument's tuning machine (screws included) so your tuner is always at hand and visible only to you.

- Clip-Free mount screws directly into 1 tuning machine screw hole:
 - No additional holes needed
 - Tuner comes with the needed screw
- Same great features as the standard NS Micro Headstock Tuner:
 - Fast, accurate response
 - Calibration from 410 - 480 Hz

Item #	Retail
PW-CT-21	\$28.45



TOP★SELLER

NS Micro Headstock Tuner

The feature-packed tuner your audience will never see. This tuner features a reversible multi-color display and a visual metronome in a housing that blends with the aesthetics of any instrument. It's so small, convenient and accurate, you'll want one for every instrument you own!

- Mounts behind or on front of headstock
- Reversible multi-color display
- Fast and accurate tuning
- Wide calibration range (410 - 480 Hz)
- Visual metronome

Item #	Description	Retail
PW-CT-12	Single Pack	\$28.80
PW-CT-12TP	Twin Pack	\$51.45



NS Micro Universal Tuner

The feature-packed tuner with limitless positioning options. This precision tuner features a multi-color, reversible display and metronome in an attractive, compact design. The dual-swivel clip-on mount allows for virtually any positioning on most instruments, permitting a clear view of the easy-to-read display. The retractable swivel arm also allows the tuner to be folded down, so it's out of the way when not in use.

- Easy-to-use dual-swivel arm mount
- Visual metronome
- Reversible multi-color display
- Wide calibration range (410 - 480 Hz)
- Limitless positioning options on most instruments

Item #	Retail
PW-CT-13	\$31.50



NS Micro Violin Tuner

The NS Micro Violin Tuner features an easy-to-read multi-color display and metronome in an attractive, compact design. A non-marring lever-lock clamp holds the tuner securely to the instrument, while allowing easy application and removal. The precision violin tuner is not only perfect for tuning, the unique mounting system and fast pitch response allow it to be used as an effective practice tool for referencing and improving intonation while playing.

- Easy-to-use lever-lock clamp
- Visual metronome
- Reversible multi-color display
- Wide calibration range (410 - 480 Hz)
- Perfect for tuning and practicing

Item #	Retail
PW-CT-14	\$37.30



US Patent #D703263

TUNERS



Clip-On Headstock Tuner

The D'Addario Clip-On Headstock Tuner precisely tunes guitars, basses, and other stringed instruments, utilizing vibrations rather than sound. Using a highly sensitive piezo sensor and large multi-color display, the Clip-On Headstock Tuner allows you to tune easily and accurately in noisy and dimly lit environments, where many other tuners fail. The tuner features a flip-up display that automatically turns on the tuner when opened and off when closed. The 360° rotatable display allows various viewing angles, and use on right-hand and left-handed instruments.

- Large, multi-color flip-up display
- 360° rotation
- Reversible screen
- Wide calibration range 410 - 480 Hz

Item #	Retail
PW-CT-10	\$37.30

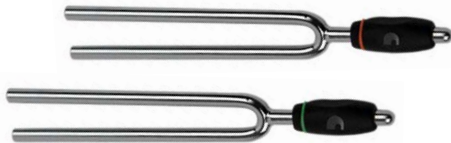

Tuning Forks

- Precision-designed to offer extremely accurate tuning (440 Hz for A, 329.6 Hz for E)
- Molded, ergonomic handle is easy to hold
- Color-coded O-rings allow easy key identification

Item #	Description	Retail
PWTF-E	Tuning Fork-E	\$14.85
PWTF-A	Tuning Fork-A	\$14.85

POWER & BATTERIES



NEW! 9V Batteries

Designed specifically for high-power devices, D'Addario 9V batteries deliver up to 9 volts of premium power. Using the latest technology, these tour-grade alkaline batteries provide dependable, long-lasting performance in power-hungry electronic devices.

- 2-pack and 5-pack available
- High performance
- Long life

Item #	Retail
PW-9V-02	\$14.55
PW-9V-05	\$36.25



Lithium Battery (4-Pack)

D'Addario Lithium batteries provide up to 3 volts of power and are intended for use with D'Addario tuners, Humidity & Temperature Sensor and other electronic devices. Using proven technology, these batteries provide longer life in most devices.

Item #	Retail
PW-CR2032-04	\$7.25

9V Power Adaptor

The D'Addario Power Adaptor works with 9V tip (-) devices to minimize the need to change batteries.

- Powers 9 volt, negative tip effects
- Max Current of 300mA



Item #	Retail
PW-CT-9V	\$15.25

CHOOSING THE RIGHT CAPO IN THREE STEPS...

1

RADIUSED FRETBOARD

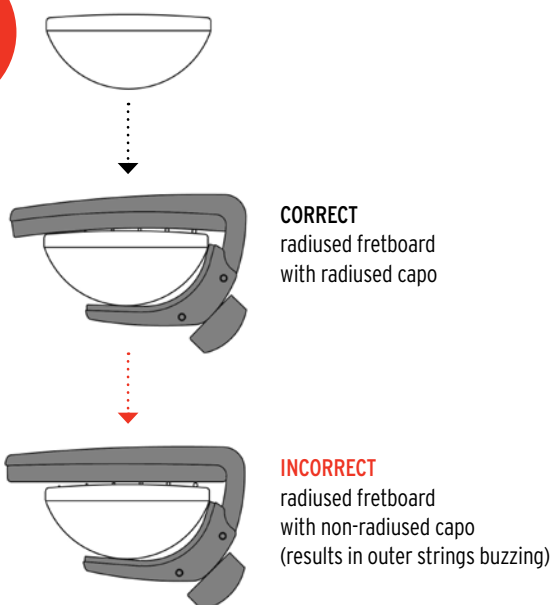

FLAT FRETBOARD

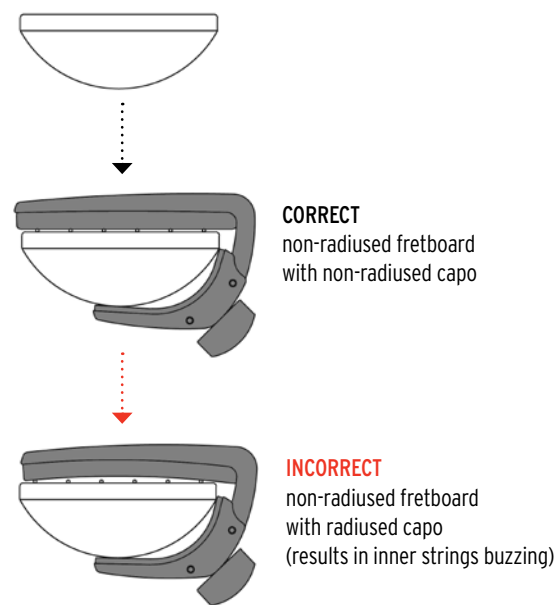

2

HIGH PERFORMANCE (NS Pro)

- Proprietary micrometer adjustment geometry allows you to dial in just the right amount of tension needed for your strings to ring clearly at any fret without excessive tension.
- Aircraft-grade aluminum material adds the slightest amount of weight to your neck, which maximizes the natural resonance and vibration of your instrument.

ENTRY LEVEL (NS Lite)

- Made of high-impact plastic
- Offers adjustable tension
- Low cost
- Utilizes a patented geometry which closes the lower jaw against the back of the neck without pulling the strings side to side like ordinary, single-action capos
- Not recommended for 12-string or instruments with high action

3

SCREW STYLE (NS Pro)

- Extremely precise tension adjustment; perfect for studio and critical recording
- Compact, low profile design
- Single-hand operation
- In-tune performance at any fret
- Available for radiused and flat fingerboards
- Trio, partial capo for drop E and A tunings, banjos, and mandolins

TRIGGER STYLE (NS Artist, Tri-Action)

- Precise tension adjustment
- Single-hand operation
- Extremely fast application and removal; perfect for live use
- Attaches to the headstock for convenient storage
- In-tune performance at any fret



NEW! NS Cradle Capo

With its stainless steel, self-centering design, the Cradle Capo ensures even tension across the fretboard. Its adjustable micrometer lets you dial in the perfect pressure, while allowing the freedom for quick transitions and the ability to stay on the guitar, even when not in use. Designed in collaboration with Ned Steinberger.

- Always-ready design with even tension thanks to the self-centering cradle
- Able to store above the guitar nut when not in use and/or stored in a case
- Made from durable stainless steel
- Designed in collaboration with Ned Steinberger



Item #	Retail
PW-CP-18	\$104.40

NS Artist Series Capos

All of our NS Artist Series Capos utilize a patented trigger geometry which reduces the force required to open and close the capo while applying even tension regardless of neck profile. Combined with the micrometer tension adjustment and direct horizontal pressure, the NS Artist Capo virtually eliminates pulling the strings side to side and the need to retune during use. Additionally, the front load trigger design and lightweight aluminum construction adds no obstruction or noticeable weight to the neck of the instrument. It also includes an integrated pick holder and NS Micro Tuner mounting bracket, allowing you to add tuning capabilities to the capo.

US Patent #8,779,262

- Micrometer tension adjustment assures buzz-free, in-tune performance at every fret
- Trigger geometry offers easy use and even clamping tension
- Lightweight aircraft-grade aluminum construction
- Integrated pick holder
- NS Micro Tuner mounting bracket

TOP★SELLER

NS Artist Capo

Designed for use on 6-string electric and acoustic guitars.

Item #	Description	Retail
PW-CP-10	Black	\$37.65
PW-CP-10S	Silver	\$37.65
PW-CP-10MBR	Metallic bronze	\$37.65
PW-CP-10MG	Metallic gray	\$37.65



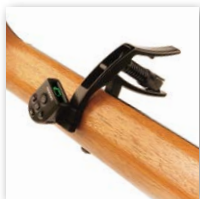

NS Artist Capo with NS Micro Headstock Tuner

Two of D'Addario's best-selling products in one convenient bundle. The NS Micro Tuner comes with 2 mounting capabilities: a bracket to secure the tuner to the NS Artist Capo and the headstock ratchet.

Item #	Retail
PW-CP-10NSM	\$60.15

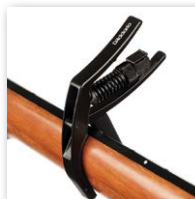

NS Artist Classical Capo

Designed for use on classical and nylon guitars with flat (non-radiused) fretboards.

Item #	Retail
PW-CP-13	\$37.65



NS Artist Drop Tune Capo

Designed to simulate drop-tuning on standard-tuned guitars.

Item #	Retail
PW-CP-15	\$37.65



NS Artist DADGAD Capo

Designed to simulate DADGAD tuning on standard-tuned guitars.

Item #	Retail
PW-CP-14	\$37.65



NS Capo Pro Series

The NS Capo Pro Series assures buzz-free, in-tune performance at every fret. A micrometer adjustment mechanism allows you to dial in the exact tension needed for clear-ringing notes without excessive force in any position on the neck. This greatly reduces the need to retune your guitar during and after capo use. The sleek construction can withstand the toughest playing and touring schedule while adding negligible weight or obstruction to the instrument.

US Patent #D521,048S

- Designed for acoustic and electric 6- or 12-string steel string and nylon guitars, ukulele, banjo and mandolin
- Micrometer tension adjustment assures buzz-free, in-tune performance at every fret
- Lightweight construction



TOP★SELLER

NS Capo Pro

Designed for acoustic and electric 6- or 12-string guitars with radiused fretboards.

Item #	Description	Retail
PW-CP-02	Black	\$33.50
PW-CP-02S	Silver	\$33.50
PW-CP-02MBR	Metallic bronze	\$33.50
PW-CP-02MG	Metallic gray	\$33.50



NS Classical Capo Pro

Designed for use on classical guitars with a flat radius.

Item #	Retail
PW-CP-04	\$33.50



NS Banjo/Mandolin Capo Pro

Designed for 4- or 5-string banjos and mandolins.

Item #	Retail
PW-CP-11	\$31.80





NS Ukulele Capo Pro

Designed specifically for ukulele.

Item #	Retail
PW-CP-12	\$31.80



The Ukulele Capo design is the best I've ever seen. D'Addario makes being a musician so much cooler.
Jake Shimabukuro



NS Classical Lite Capo

Designed for use on classical guitars with a flat radius. NS Pro function at an affordable price.

Item #	Retail
PW-CP-16	\$18.95



NS Drop Tune Capo Pro

Designed for partial capo drop tunings on 6- or 12-string guitars with radiused fretboards, and can also function as an effective capo for banjo, mandolin, or ukulele.

Item #	Retail
PW-CP-06	\$33.50

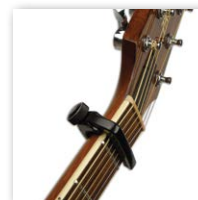

TOP ★ SELLER

NS Lite Capo

Designed for acoustic and electric 6-string guitars with radiused fretboards. NS Pro function at an affordable price.

Item #	Retail
PW-CP-07	\$18.95

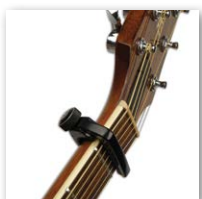

NS Lite Capo Fish Bowl

D'Addario's best-selling NS Lite Capo in a convenient POP fish bowl counter display. Each fish bowl comes with 25 individually packaged capos.

Item #	Retail
PW-CP-0725	\$16.50*

*Must be ordered in increments of 25. Retail value of \$412.50.



NS Tri-Action Series Capos

The patented Tri-Action Capo reduces the force required to open and close the capo and applies even tension regardless of neck profile. Combined with the micrometer tension adjustment and direct horizontal pressure, the Tri-Action Capo virtually eliminates pulling the strings side to side and the need to retune during use. The sleek, rear-loaded trigger construction can withstand the toughest playing and touring schedule while adding negligible weight or obstruction to the instrument.

- Designed for use on 6-string electric and acoustic guitars
- Micrometer tension adjustment assures buzz-free, in-tune performance at every fret
- Tri-Action geometry offers easy use and even clamping tension
- Lightweight aircraft-grade aluminum construction
- Integrated pick holder

US Patent #8,779,262

Item #	Description	Retail
PW-CP-09	Black	\$37.65
PW-CP-09S	Silver	\$37.65

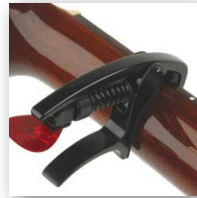

Ratchet Capo

The D'Addario Ratchet Capo uses a unique ratchet design to lock strings into place at any desired fret. One press of the quick release lever unlocks the capo for placement around the guitar's neck. Once in position, firmly squeeze the capo using the finger tabs to lock the capo in place.

- Unique ratchet design with quick release
- One firm squeeze of finger tabs locks capo in place
- Padded at all points of contact with guitar to prevent scratching or marring of finish

Item #	Retail
PW-CP-01	\$17.70

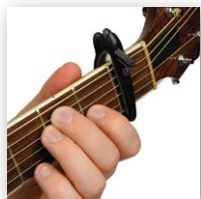



Dynaflex™

Dynaflex allows you to achieve a competitive edge, no matter what instrument you play. This handheld gyroscope builds and conditions hands, wrists, and forearms while also increasing hand speed and endurance. Simply start the rotation and then, with a rocking motion, build up the gyroscopic speed and feel the burn.

- Exercises and conditions hands, wrists, and forearms
- Increases hand speed
- Improves endurance
- Great for pre-show warm-up

Item #	Retail
PW-DFP-01	\$44.50

TOP ★ SELLER

Varigrip™

D'Addario Varigrip is the ultimate conditioning tool for musicians. Designed to develop and maintain the strength and dexterity of your fingers and hands, Varigrip's ergonomic design and variable tension provides customized conditioning for individual fingers, the entire hand, wrist, and forearm. The reversible molded grip even uncovers simulated strings to help develop and maintain finger calluses when you are away from your instrument.

US Patent #7967732

Item #	Retail
PW-VG-01	\$23.20



Simulated strings for building & maintaining calluses

MAINTENANCE TOOLS & SUPPORT



NEW! Maintenance Kits

The D'Addario Electric Guitar and Bass Maintenance Kits give you everything you need to keep your instrument playing and sounding its best – from the included string winder and neck cradle, to the multi-tool and maintenance products, this kit contains all the essentials for players of every skill and style. The included storage case also provides easy access to all these products for the ultimate care of your acoustic and electric guitars and basses.

- High-quality travel case
- Non-slip protective body mat
- String height gauge

Includes other best-selling accessories such as:

- Pro-winder (Bass Pro-Winder for the Bass Kit)
- Headstand
- Multi-tool
- Lubrikit
- Fret Polishing System
- NS Capo Lite

Item #	Description	Retail
PW-EGMK-01	Guitar Kit	\$130.15
PW-EBMK-01	Bass Kit	\$130.15

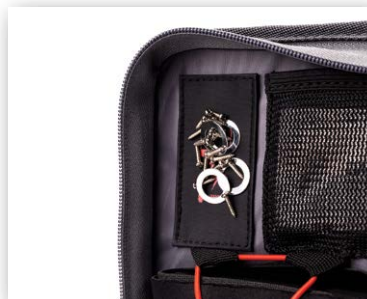

hardware magnet



protective body mat

NEW! Guitar/Bass Multi-Tool

The D'Addario Multi-Tool provides the tools needed for most standard adjustments on your guitar and bass. The multi-tool features US and metric-sized keys made of long-lasting, heat-treated S2 steel in a compact design. At home, in the studio, or on the road, D'Addario has the tools to keep you and your instrument playing their best.

- 10-in-1 Multi-Tool
- US and Metric sizes featuring:
 - 3 Fractional hex keys (0.05, 1/8, 3/16)
 - 4 Metric hex keys (1.5mm, 2.5mm, 3mm, 4mm)
 - 2 Phillips screwdrivers
 - 1 slotted screwdriver

Item #	Retail
PW-GBMT-01	\$24.90



7 Hex Keys



Phillips and Slotted Head Screwdrivers



Good for:

- Intonation
- Pickup height
- String height
- Tightening loose tuners
- Locking tremolos and nuts
- Hardware adjustments or on-the-gig repairs

MAINTENANCE TOOLS & SUPPORT

TOP ★ SELLER

Pro-Winder™

The ultimate restringing tool. Unlike ordinary peg winders, the Pro-Winder is a high-quality peg winder with a built-in string clipper and bridge pin puller.

Item #	Description	Retail
DP0002	Pro-Winder	\$18.65
DP0002B	Bass Pro-Winder	\$18.65



Peg Winders

The specially designed, ergonomic Peg Winder fits virtually all guitars, basses, banjos, and mandolins.

Item #	Description	Retail
PWPW1	Peg Winder	\$11.65
PWPW1B	Bass Peg Winder	\$11.65

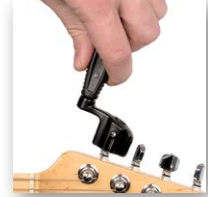

Turbotune Peg Winder

Easy to use and find on dark stages, the patented glow-in-the-dark Turbotune Peg Winder allows quick restringing of most stringed instruments. The removable winder socket can be used with the included crank handle or placed in an electric screwdriver for maximum ease and speed. The Turbotune also includes an integrated bridge pin puller.

Item #	Retail
PW-TTPW-01	\$24.35

Patent# 6,294,719



Glow in the dark!



Fits mini, full, and bass-sized tuners



Detachable socket for use with electric screwdrivers



Drill Bit Peg Winder

The D'Addario Drill Bit Peg Winder attaches to any cordless power screwdriver for faster and easier string changes. Built from a high performance polymer, the peg winder can accommodate vintage to modern guitar and bass tuners in a one-size-fits-all design, while the nickel-plated steel shaft will resist wear for countless string changes.

- Attaches to any cordless power screwdriver
- Allows for faster and easier string changes
- Accommodates vintage to modern guitar and bass tuners in a one-size-fits-all design
- Nickel-plated steel shaft will resist wear for countless string changes

Patents Pending

Item #	Retail
PW-DBPW-01	\$11.05



Guitar Dock

The D'Addario Guitar Dock allows you to turn any surface with a flat edge into an instrument stand, protecting your instrument when a stand is inconvenient or not available. This includes tables, chairs, work benches, consoles and more.

- Adjustable clamp turns any flat surface with an edge into an instrument stand
- 360° rotation allows mounting at multiple angles
- Durable overmold protects instrument and clamping surfaces
- Lightweight, compact and portable

Item #	Retail
PW-GD-01	\$44.55

The Headstand™

- Securely supports guitars and basses for hassle-free string changes
- Folds up for easy storage
- Will not damage instrument finish

Item #	Retail
PW-HDS	\$20.50



The Guitar Rest

The D'Addario Guitar Rest turns any flat surface into a guitar stand. Simply lay the Guitar Rest over the edge of any level surface and lean your instrument against the "neck pocket" of the Guitar Rest. The surface friction of the guitar rest will resist movement on practically all surfaces. Perfect for instances where a stand is not available or convenient.

Item #	Retail
PW-GR-01	\$15.10

Patent# D619,8255



POLISHES & CLOTHS

NEW! Instrument Care Kit

The D'Addario Instrument Care Kit gives you everything you need to keep your instrument playing, looking and sounding its best - from the included headstand neck cradle to the cleaning and care products, this kit contains all the essentials for players of every skill and style. The included storage case also provides easy access to all these products for the ultimate care of your acoustic, electric and bass guitar.

- High-quality travel case
- Non-slip protective body mat

Includes best-selling accessories such as

- 3-step polishing system
- Hydrate Fretboard Conditioner
- Headstand
- Micro-Fiber Polish Cloth
- Fret Polishing System
- XLR8

Item #	Retail
PW-ECK-01	\$119.30



Step 1: Restore Deep-Cleaning Cream Polish

D'Addario RESTORE Deep-Cleaning Cream Polish is a rich formula designed to cut through the toughest grime. Safe on all common guitar finishes to polish out swirl marks and even minor scratches.

Item #	Description	Retail
PW-PL-01	4-oz bottle	\$11.65
PW-PL-01S	1-oz bottle	\$6.80



Hydrate Fretboard Conditioner

D'Addario Hydrate is the ultimate treatment to restore the silky feel and character of dark, natural wood fingerboards. This unique formula of oils and cleaners removes dirt and grime while restoring moisture to the fretboard, preventing cracks and other damage.

Item #	Description	Retail
PW-FBC	2 oz bottle	\$8.20
PW-FBCS	1 oz bottle	\$5.70



Step 2: Protect Pure Liquid Carnauba Wax

D'Addario PROTECT is a natural protectant and sealer, combining premium-quality Brazilian Carnauba wax and advanced chemistry to produce a distinct radiance with quick and easy application.

Item #	Description	Retail
PW-PL-02	4 oz bottle	\$11.65
PW-PL-02S	1 oz bottle	\$6.80



Lemon Oil

D'Addario Lemon Oil is a natural cleaner and conditioner formulated to remove dirt, grease, and wax build-up. Lemon Oil also conditions to resist dryness and extend the life of your instrument. Recommended for use on unfinished woods.

Item #	Description	Retail
PW-LMN	2 oz bottle	\$7.30



Step 3: Shine Spray Cleaner & Maintainer

D'Addario SHINE Spray Cleaner & Maintainer keeps your finish looking like new every day. SHINE erases dust, fingerprints, and minor imperfections, while color enhancers bring out your instrument's beauty.

Item #	Description	Retail
PW-PL-03	4 oz bottle	\$11.65
PW-PL-03S	2 oz bottle	\$6.80



XLR8

D'Addario XLR8 lubricates and cleans your strings for faster playing and longer life. Simply wipe the easy-to-use applicator up and down your strings and enjoy the frictionless feel of the strings, allowing you to play faster while also experiencing less finger noise and enhanced tone.

- Removes friction for faster playing
- Enhances string life and tone
- Reduces finger noise
- Easy-to-use applicator

Item #	Retail
PW-XLR8-01	\$11.65



Renew String Cleaner

This string cleaning system preserves that new string tone and feel. The patented string cleaner cleans both the top and bottom of the strings, removing dirt and build-up that can prematurely make strings sound lifeless. Individually packaged in a convenient POP counter display. 50 packs in each fish bowl.

- Convenient and effective string cleaning system
- Cleans, preserves tone, and prolongs string life
- Safe and recommended for all strings



Item #	Description	Retail
PW-RSCS-03	3-pack	\$12.75
PW-RSCS-50	Single-pack	\$3.80*

*Must be ordered in quantities of 50.
Retail value of \$190.00

U.S. patent: 7,518,047

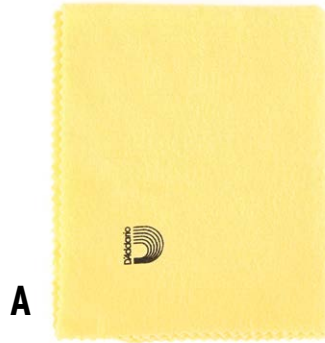

A



B

A. Untreated Polishing Cloth

Made from high-quality, double-napped cotton flannel, D'Addario Polishing Cloths last longer and pick up dust and dirt more effectively than ordinary polishing cloths.

Item #	Retail
PWPC2	\$8.75

B. Pre-Treated Polishing Cloth

Made from double-napped cotton flannel, D'Addario Pre-Treated Polishing Cloths are produced with cleaner built into the cloth so there is no need for extra polish.

Item #	Retail
PWPC1	\$10.30



Lubrikit Friction Remover

Friction is the root cause of all tuning problems. Just a drop of Lubrikit removes the friction so you can play in tune.

- Provides tuning stability
- Combats string breakage
- Ends premature wear at bridge and nut
- Increases sustain and overall performance

Item #	Retail
PW-LBK-01	\$21.00

Micro-Fiber Polishing Cloth

This D'Addario cloth traps particles deep inside its fibers (2000 times finer than a human hair) and eliminates the need for harmful cleansers, lasts considerably longer than ordinary cloths, and can be washed multiple times.

Item #	Retail
PW-MPC	\$12.85



Fret Polishing System

The D'Addario Fret Polishing System is the secret to making a guitar's frets shine like new. The easiest way to improve your instrument's performance, tone and appearance.

Item #	Retail
PW-FRP	\$11.65



HUMIDITY CONTROL



ACTUAL SIZE

Humiditrak™

Musical instruments can be easily damaged by large and rapid changes in humidity and temperature. Now you can protect your investments by simply placing D'Addario's Humiditrak with Blustream Technology™ inside your instrument or case. Humiditrak uses a patent-pending Bluetooth™ sensor to provide a constant stream of temperature, humidity, and impact data to the free smartphone app alerting you of hazardous conditions that can lead to diminished playability, costly repairs, and lost value to your instrument. When Humiditrak detects dangerous conditions, push notifications are sent to your device, allowing you to take corrective action before damage occurs. Cataloging and monitoring a collection of instruments is so easy and convenient, you'll want one for every instrument you own!

Item #	Retail
PW-HTK-01	\$87.45

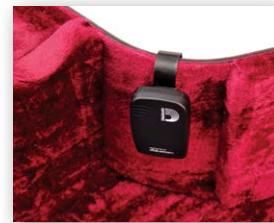

Monitor humidity, temperature & impact

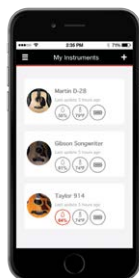

View status of all your instruments on one easy-to-read display



Receive push notifications of hazardous conditions

- iOS/Android instrument monitoring
- Hourly, daily & monthly data tracking
- Easily installs within instrument or case
- Automatic push notifications of hazardous conditions



TOP★SELLER

Humidipak™: Two-Way Humidification System

D'Addario brings you Boveda's® patented technology as part of our instrument care line. Boveda is the first two-way humidity control that maintains a constant 45-50% Relative Humidity level inside your instrument case. The patented Two-Way Humidification System completely eliminates all the guesswork and anxiety of maintaining your instrument's proper humidity level. No more guessing if or when to refill the humidifier and worrying about drips or mess. No more manual adjustments based on seasonal changes, geographic locations, temperature, or other factors. Unlike all refillable humidifiers, this humidification system provides true two-way purified humidity control since it adds or depletes moisture only as needed to maintain 45-50% RH – the ideal climate for wooden instruments.

Item #	Description	Retail
PW-HPK-01	Humidipak Maintain Kit	\$45.35
PW-HPRP-03	Standard Refill Packet - 3-pack	\$29.15
PW-HPRP-12	Standard Refill Packet - 12-pack	\$101.85
PW-HPCP-03	Restore Packet - 3-pack	\$29.15
NEW! PW-HPK-03	Humidipak Restore Kit	\$45.35

Boveda's technology is protected by one or more of the following patents:
5936178, 2298597, 1064644, 6921026, 6244432, 8748723.



NEW! Humidikit™

The D'Addario Humidikit™ all-in-one humidification maintenance and monitoring system gives you everything you need to ensure your instrument stays safe and playable. The system includes a D'Addario Humiditrak™ with Blustream Technology™ to provide a constant stream of temperature, humidity, and impact data directly to your smartphone via Bluetooth™. It also contains a Humidipak™ Starter Kit, featuring Boveda's® patented two-way automatic humidity control technology, to maintain the ideal humidity level inside your instrument case. Whether your instrument is across the country or at your fingertips, you can rest assured that D'Addario's Humidikit is giving your instrument the complete care it deserves.

- Humidikit bundle contains one Humidipak Kit (pouches and packets) and one Humiditrak Bluetooth sensor
- Free Smartphone App available for iOS and Android

Item #	Retail
PW-HPHT-01	\$135.60



Humidity & Temperature Sensor

The D'Addario Humidity & Temperature Sensor (HTS) will help monitor your instrument's climatic conditions to avoid damage and costly repairs.

- The precision-designed hygrometer digitally indicates accurate Relative Humidity level
- Temperature is displayed in either Fahrenheit or Celsius
- Includes memory of highest and lowest readings with date and time stamp

Item #	Description	Retail
PW-HTS	Humidity & Temperature Sensor	\$45.55
PW-GH-HTS	Acoustic Guitar Humidifier with HTS	\$71.00

Humidifier Pro

The D'Addario Humidifier Pro, for guitars and now ukuleles, uses a specialized hydrophilic sponge that holds 12 times its dry weight in water (much more than ordinary sponges), which allows for longer periods between refills and increases protection in drier environments. Preserving your instrument's ultimate playability by guarding against cracks, warped necks, and shrinkage is now easier and less work. Suspended by the strings, the humidifier releases moisture evenly and slowly inside your instrument, yet never touches the instrument's body. The humidifier's stopper allows you to check the sponge without removal of the unit and provides a tight seal when in place. Maintaining the humidifier is as easy as moistening the sponge when it becomes dry.

- Specialized sponge holds 12x its weight in water
- Longer time between refills
- Stopper allows quick status check without removing the humidifier from the guitar

Item #	Description	Retail
GHP	Acoustic Guitar Humidifier Pro	\$21.05
NEW! GHP-RS	GHP Replacement Sponge 2-Pack	\$10.60
UHP	Ukulele Humidifier Pro	\$18.85



HUMIDITY CONTROL



TOP★SELLER

Acoustic Guitar Humidifier

The Acoustic Guitar Humidifier releases moisture evenly and slowly inside your instrument's case to maintain the proper humidity level, preventing cracks, warping, and shrinkage. Using the humidifier is as easy as moistening the sponge when it becomes dry. The Acoustic Guitar Humidifier can also be used in conjunction with the D'Addario Small Instrument Humidifier (PW-SIH-01) for acoustic guitar cases when your humidity is consistently 20% or lower. Get one for all of your valuable instruments. It's the smart, easy, and affordable way to protect your investments.

- Soundhole suspended humidifier
- Never touches instrument body
- Releases moisture evenly

Item #	Description	Retail
GH	Acoustic Guitar Humidifier	\$12.10
GH-RS	Replacement Sponges (3)	\$8.85



Small Instrument Humidifier

The Small Instrument Humidifier releases moisture evenly and slowly inside your instrument's case to maintain the proper humidity level, preventing cracks, warping, and shrinkage. Using the humidifier is as easy as moistening the sponge when it becomes dry. The small instrument humidifier can also be used in conjunction with the Acoustic Guitar Humidifier (GH) for acoustic guitar cases when your humidity is consistently 20% or lower. Get one for all of your valuable instruments. It's the smart, easy, and affordable way to protect your investments.

- Small size fits in any case
- Ideal for smaller acoustic, orchestral, and woodwind instruments
- Releases moisture slowly and evenly
- Safe for all instruments

Item #	Retail
PW-SIH-01	\$11.65



NEW! Screeching Halt™ Humidifier

The D'Addario Screeching Halt Humidifier allows you to humidify your guitar's body and neck joint, even in the driest conditions while on display, or during extended periods when your instrument will be outside its case. The humidifier releases moisture slowly and evenly while capturing the vapor inside the body of the instrument to retain the proper humidity level. Maintaining the humidifier is as simple as moistening the sponge when the humidity falls below a safe level (40-60% Relative Humidity). The Screeching Halt Humidifier can also be used as a feedback reducer when playing live, keeping your guitar properly humidified even during performances.

- Doubles as a feedback reducer and humidifier
- Humidifies the guitar outside of its case.
- Comes with hydrophilic sponge that holds 12x its weight in water

Item #	Retail
PW-ASHH-01	\$19.50



TOP ★ SELLER

Screeching Halt™

Take your electric acoustic playing to new levels...in volume, that is. The D'Addario Screeching Halt soundhole plug allows you to play your electric acoustic at far greater volume without unwanted feedback or howling. The tapered design allows for a great fit in most soundholes, while the inert material is safe for your guitar's finish. Simply place the Screeching Halt into your acoustic's soundhole and enjoy a feedback-free performance.

- Eliminate feedback and enhance stage volume
- Soft rubber insert is safe for guitar finishes
- Tapered design allows greater fit for a variety of guitars
- Quick and easy to install and remove

Item #	Retail
PW-SH-01	\$12.50



O-Port™

The O-Port will make any guitar sound richer, fuller, and louder, with more clarity and better projection. The O-Port material is custom blended for flexibility to prevent damage to your guitar finish and inlays. The O-Port will suppress feedback and give your acoustic or electric acoustic guitar a fuller sound with more volume, better clarity and enhanced projection.

- Simple installation by loosening or removing strings and fitting O-Port into soundhole
- Suppresses feedback
- Richer, fuller, louder sound with more clarity and better projection
- Available in two sizes to accommodate large and small soundholes



Item #	Description	Retail
PW-OPBKL	Black - Large	\$40.75
PW-OPBKS	Black - Small	\$40.75
PW-OPWHL	Ivory - Large	\$40.75
PW-OPWHS	Ivory - Small	\$40.75
PW-OPBKL-10B	Black - Large / Bulk 10-Pack	\$209.35

Before-and-After Comparison:

Standard Guitar
5th Fret Harmonic

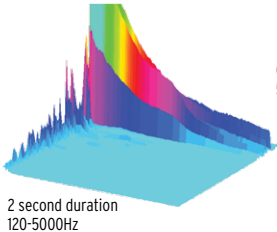

O-Port Guitar
5th Fret Harmonic

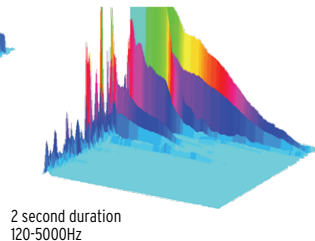

The O-Port really brings out the best qualities of my favorite guitars. I have one in every acoustic!
Devin Townsend

GUITAR SLIDES



Rich Robinson Brass Slide

Founding member of the Black Crowes and solo artist Rich Robinson is recognized as one of today's top slide players and known for his use of open tunings. Rich teamed up with D'Addario to create his signature slide. Made from solid brass, the satin finished slide features a custom interior taper to Rich's specifications. At home on both acoustic and electric guitars, Rich's signature slide gives you comfort, control, and exceptional tone.

Item #	Retail
PWBS-RR	\$35.75



Chrome-Plated Brass Slide

D'Addario Chrome-Plated Brass Slides provide a bright, bell-like tone with excellent sustain. The solid brass is chrome-plated to a mirror-like shine for effortless gliding and ease of playing.

Item #	Description	Retail
PWCBS-SS	Small	\$16.35
PWCBS-SM	Medium	\$21.00
PWCBS-SL	Large	\$21.00



Glass Bottle Slide

The Glass Bottle Slide is the secret behind the tones of many great slide players, past and present. Based on the specifications of a vintage medicine bottle, the unique glass surface and lightweight offer excellent tone, sustain, and playability.

- Unique glass surface for excellent tone and sustain
- Lightweight glass improves playability on guitars with lower action

Item #	Retail
PWGS-B	\$12.85



Glass Slides

D'Addario Glass Slides are made from boron silicate for enhanced durability, smoothness, and tone. Each slide is individually heat-treated to provide smooth edges and a perfect finish. Available in small, medium, and large.

Item #	Description	Retail
PWGS-SS	Glass Slide - Small	\$11.65
PWGS-SM	Glass Slide - Medium	\$11.65
PWGS-SL	Glass Slide - Large	\$11.65



D-Slyde™

The D'Addario D-Slyde is a premium glass guitar slide that attaches to any surface by the use of hook-and-loop material adhered to the custom flat surface of the slide. Each D-Slyde is handmade to achieve its custom shape before it's cut and fire-polished to a flawless finish.

- Mount slide to guitar headstock, mic stand, anywhere!
- Premium quality glass slide
- Warm tone and great sustain

Item #	Description	Retail
PWGS-DSS	Small	\$21.00
PWGS-DSM	Medium	\$21.00
PWGS-DSL	Large	\$21.00





Rotating Elliptical End Pin

D'Addario Rotating Elliptical End Pins allow easy application and removal of your strap while providing a secure locking feature. The locking ends allow the use of any strap without additional hardware or installation. Simply attach any strap and turn the top half off the end pin to securely lock it in place. Available in chrome finish only. US Patent # D679,743

Item #	Retail
PWREP202	\$28.05



Elliptical End Pins

The D'Addario Elliptical End Pins are not your ordinary end pins. The elliptical design combines function and style by securing any strap in place while complementing the aesthetics of any guitar or bass.

- Safely secures strap to instrument
- Works with all guitars and basses
- Easy installation

US Patent # D679,743

Item #	Description	Retail
PWEEP102	Black	\$11.25
PWEEP202	Chrome	\$11.25
PWEEP302	Gold	\$11.25



Solid Brass Guitar Strap End Pins

Designed to fit perfectly with D'Addario leather end and Planet Lock end guitar straps, D'Addario Guitar Strap End Pins are precision machined in the USA from solid brass stock.

Item #	Description	Retail
PWEP102	2 Black Oxide End Pins	\$11.25
PWEP202	2 Chrome End Pins	\$11.25
PWEP302	2 Brass End Pins	\$11.25



BRIDGE PINS & HARDWARE



NEW! Titanium Bridge Pin Set

The D'Addario Titanium Bridge Pins help take the tone and sustain of your acoustic to the next level.

- Enhanced tone for your acoustic guitar
- Increased sustain

Item #	Retail
PWPS13	\$109.95



Wood Bridge and End Pins

D'Addario Wood Bridge and End Pins are made from high-quality exotic woods, which enhance tone and last longer than ordinary plastic bridge pins.



Item #	Description	Retail
PWPS1	7 ebony bridge pins + 1 ebony end pin	\$25.35
PWPS2	7 ebony bridge pins + 1 ebony end pin with abalone inlay	\$41.75
PWPS3	7 ebony bridge pins + 1 ebony end pin with pearl inlay	\$41.75
PWPS6	7 boxwood bridge pins + 1 boxwood end pin	\$29.90

Molded Bridge and End Pins

D'Addario Molded Bridge and End Pins are precision molded from high-quality ABS plastic and offer extra strength and durability.



Item #	Description	Retail
PWPS9	7 plastic bridge pins + 1 plastic end pin - black	\$7.15
PWPS10	7 plastic bridge pins + 1 plastic end pin - black w/ivory dot	\$7.15
PWPS11	7 plastic bridge pins + 1 plastic end pin - ivory	\$7.15
PWPS12	7 plastic bridge pins + 1 plastic end pin - ivory w/black dot	\$7.15



Auto-Trim™ Tuning Machines (an NS Design product)

(With patented built-in String Cutters)

The D'Addario Auto-Trim Tuning Machines are precision tuners that automatically cut the excess string while changing strings, eliminating the need for string cutting tools to make string changes easy and fast. The 18:1 ratio worm gear construction ensures greater precision and tuning stability even during the hardest playing. Includes 6 tuners and mounting hardware. US Patent #6,365,809

Item #	Description	Retail
PWAT-6R1	(In-Line) Chrome Finish	\$133.70
PWAT-6R2	(In-Line) Black Finish	\$139.55
PWAT-6R3	(In-Line) Gold Finish	\$157.00
PWAT-331L	(3+3 version) Chrome Finish	\$133.70
PWAT-332L	(3+3 version) Black Finish	\$139.55
PWAT-333L	(3+3 version) Gold Finish	\$157.00

HEARING PROTECTION



Pacato Hearing Protection

D'Addario Pacato Hearing Protection is a reusable, universal-sized audio filter designed specifically for musicians and music enthusiasts. While other hearing protection can sound muffled and unnatural, Pacato filters provide full frequency and enjoyable audio at safe listening levels. The exclusive design offers an open air passage to the ear, minimizing occlusion effects (low frequency emphasis) while keeping the ear ventilated for unmatched comfort.

- Provides a noise reduction rating of 19dB
- Includes large and small earplugs, lanyard, and carrying case

Item #	Retail
PWPEP1	\$43.15



Comfort Fit Ear Plugs

D'Addario Comfort Fit Ear Plugs are made from slow recovery PVC foam, and provide a noise reduction rating of 29 dBs.

Item #	Description	Retail
PWEP1	1 pair	\$2.65
PWEP3	3 pairs	\$7.05
PWEP100	100 pairs in fish bowl	\$209.35

YOUR FAVORITE STRAPS AVAILABLE 3 WAYS!

1

LEATHER END

D'Addario standard leather end straps are far from standard. Meeting tight aesthetic, dimensional, and structural specifications, these leather ends can hold up to just about any abuse and fit all standard strap pins.



2

PLANET LOCK

The patented design of Planet Lock™ fits virtually any guitar and stays locked in place until you release the side pin. Unlike ordinary strap lock systems, the Planet Lock is designed to fit securely on your guitar's existing end pin. The Planet Lock is safe, secure, and easy to use.



Patent #6,032,339

3

ACOUSTIC QUICK RELEASE

The D'Addario Acoustic Quick Release™ eliminates tying and untying knots to secure and remove your strap. Attach the loop-through end to the headstock and attach the standard end to the strap pin. Simply unclip the quick release latch to remove.



Patent #5,868,293

POLY-PRO STRAPS

**TOP★
SELLER**

Poly-Pro Guitar Straps

Choose leather ends, Planet Lock, Acoustic Quick Release, or 3" wide straps.

**MORE
PLANET LOCK
STRAPS**
PAGE 65



	Retail	Black	Silver	Green	Rainbow	Brown	Yellow	Red	Blue	White	Pink
Leather End	\$9.35	PWS100	PWS105	PWS107	PWS111	PWS109	PWS110	PWS101	PWS102	PWS108	PWS106
Planet Lock	\$23.25	PWSPL200	PWSPL205		PWSPL211	PWSPL209	PWSPL210	PWSPL201	PWSPL202	PWSPL208	
Acoustic Quick Release	\$14.85	PWSPA200			PWSPA211	PWSPA209	PWSPA210		PWSPA202		
3" Poly-Pro Strap	\$30.90	75B000						75B001	75B002		



After years of thrashing around onstage with Periphery, there have been few elements of my rig that have never failed me once, broke, or gave in to the relentless nature of the show we put on: the D'Addario Planet Lock strap. It is undoubtedly the most reliable element of my live show.

**Mark Holcomb,
Periphery**



Cotton Guitar Straps

Item #	Description	Retail
5OCT04	Brown	\$22.15
5OCT00	Black	\$22.15
5OCTPL00	Black Planet Lock (not shown)	\$27.70
5OCT03	Blue	\$22.15
5OCT02	Army	\$22.15
5OCT05	Red	\$22.15
5OCT01	Natural	\$22.15



There's nothing more reliable than a D'Addario guitar strap. They are comfortable, lightweight and just look snazzy!

**Tim Millar,
Protest the Hero**



Seatbelt Guitar Straps

Item #	Description	Retail
5OSB00	Black	\$19.95
5OSB01	Red	\$19.95
5OSB02	Blue	\$19.95

WOVEN STRAPS



Item #	Description	Retail
T20W1504	Red & Black Tartan	\$33.25
T20W1404	Red Buffalo Check	\$33.25
T20S1500	Red & Navy Gingham	\$44.20
T20W1406	Gray Buffalo Check	\$33.25
T20W1503	Black & White Tartan	\$33.25



Item #	Description	Retail
T20W1409	Black & Gray Tie	\$33.25
T20W1410	Blue & Red Tie	\$33.25
T20S1506	Black & Gray Chevron	\$33.25
T20S1505	Blue & Navy Chevron	\$33.25



**TOP★
SELLER**

Item #	Description	Retail
★ P20W1419	Blue Paisley	\$33.25
P20W1502	Paisley Critters	\$33.25
P20W1418	White Paisley	\$33.25

WOVEN STRAPS



**TOP★
SELLER**

Item #	Description	Retail
T20W1419	Black Monterey	\$37.90
★ T20W1418	Blue Monterey	\$37.90
T20W1417	Red Monterey	\$37.90
50E08	Tapestry	\$33.25
T20W1502	Diamond Monterey	\$33.25
T20W1422	Green Monterey	\$33.25
T20W1501	Diagonal Monterey	\$33.25



Item #	Description	Retail
50G01	Hootenanny 2	\$12.25
50G05	Hootenanny 3	\$12.25
50G00	Hootenanny 1	\$12.25



Item #	Description	Retail
50G02	Red Bandana	\$27.70
50G04	Camouflage	\$27.70
50G03	Blue Bandana	\$27.70

WOVEN STRAPS

Item #	Description	Retail
50C02	Black & White Checkerboard	\$33.25
P20W1421	Black & Red Large Checkerboard	\$33.25
T20W1412	Black & Gray Checkerboard	\$33.25
50H03	Black & Pink Checkerboard	\$33.25



Item #	Description	Retail
20T05	Gold Stars	\$44.20
20T04	Gothica	\$44.20
T20W1407	Silver Polka Dots	\$33.25



**TOP★
SELLER**

Item #	Description	Retail
50H08	Leopard	\$33.25
50C01	Rock Star	\$33.25
★ 50B01	Black Satin	\$33.25
T20W1500	Dragon Tattoo	\$33.25

WOVEN STRAPS



**TOP★
SELLER**

Item #	Description	Retail
50A13	Henna	\$33.25
50C08	Yellow Monterey	\$33.25
50E02	Stained Glass	\$33.25
50B06	Tweed	\$33.25
20T00	Gray Saugerties	\$33.25
20T06	Blue Twist	\$44.20
★ 50E03	Red Saugerties	\$33.25



Item #	Description	Retail
T20W1509	Checkerboard Crosses	\$33.25
20T03	Dia De Los Muertos	\$44.20
T20W1416	Argyle Crosses	\$33.25
20T02	Immortal Love	\$44.20
50F03	Cross	\$33.25

WOVEN STRAPS



Item #	Description	Retail	Item #	Description	Retail	Item #	Description	Retail
50H10	Snakeskin	\$33.25	50H09	Zebra Stripe	\$33.25	P20S1506	Skull Burst	\$33.25
P20W1505	Blossom Tattoo	\$33.25	P20S1501	Digital Camouflage	\$33.25	50H01	Skull & Crossbones	\$33.25
P20W1405	Black Camouflage	\$33.25	P20W1408	Mixed Symbols	\$33.25	P20W1500	Graffiti Stars	\$33.25

TOP ★
SELLER

Item #	Description	Retail
50A10	Stars & Stripes	\$33.25
P20W1503	Patriotic Stars	\$33.25
★ 50A11	Union Jack	\$33.25



Item #	Description	Retail
50F078	Black & Gray Tattoo	\$33.25
50F04	Barbed Wire	\$33.25
50F06	Tribal	\$33.25
50A12	Voodoo	\$33.25

WOVEN STRAPS



Item #	Description	Retail
P20W1406	Optical Art	\$33.25
P20S1507	Red Optical Stripes	\$33.25
P20S1508	White Optical Stripes	\$33.25
P20W1506	Optical Orbs	\$33.25

Item #	Description	Retail
50D01	Hold 'Em	\$33.25
50F09	Red Hot Rod Flame	\$33.25
50F10	Blue Hot Rod Flame	\$33.25
50C03	Chopper	\$33.25
P20W1401	Pinstripe	\$33.25

**TOP★
SELLER**

★

WOVEN STRAPS

Item #	Description	Retail
50A04	Rainforest	\$33.25
T20W1408	African Geometric	\$33.25
T20W1423	Tiki Masks	\$37.90
T20W1508	Gray African Geometric	\$33.25
P20W1507	African Masks	\$33.25
P20S1504	Ndebele	\$33.25
P20W1508	Black & White African Masks	\$33.25



**TOP
SELLER**

Item #	Description	Retail
P20S1503	Blue Hibiscus	\$33.25
P20S1502	Red Hibiscus	\$33.25
50A05	Tiki	\$33.25
★ 50C04	Aloha	\$33.25



Item #	Description	Retail
T20S1501	Latin Stripes	\$44.20
T20W1413	Black Guatemalan Print	\$33.25
P20W1504	Watercolor Line Art	\$33.25
T20S1503	Latin Tiles	\$44.20
T20W1403	Traditional Baja	\$32.25
T20S1502	Multi-color Line Art	\$44.20
T20S1504	Blue Latin Tiles	\$44.20

**TOP★
SELLER**

Item #	Description	Retail
P20W1411	Green Sugar Skulls	\$33.25
★ P20W1414	Red Sugar Skulls	\$33.25
P20W1412	Gray Sugar Skulls	\$33.25
P20W1415	Blue Sugar Skulls	\$33.25

WOVEN STRAPS

NEW! Premium Woven Straps

D'Addario Premium Woven Straps have the perfect balance of elegance and durability. Available in three color options, each strap comes built with brushed die-cast zinc hardware, strong seatbelt material, and reinforced garment leather ends that will outlast the toughest performances.

- Brushed die-cast zinc loops and adjuster
- 3-ply reinforced garment leather ends
- Single panel seatbelt material strap
- Adjustable from 34" - 57"

Item #	Description	Retail
50PRW00	Black	\$60.70
50PRW01	Red	\$60.70
50PRW02	Silver	\$60.70



**TOP★
SELLER**

Item #	Description	Retail
50E09	Retro Sun	\$33.25
50J04	Brown Jacquard	\$44.20
50A06	Jamaica	\$33.25
50F08	Dragon	\$33.25
★ 50A07	Celtic	\$33.25
50J00	Blue Jacquard	\$44.20



PLANET LOCK STRAPS

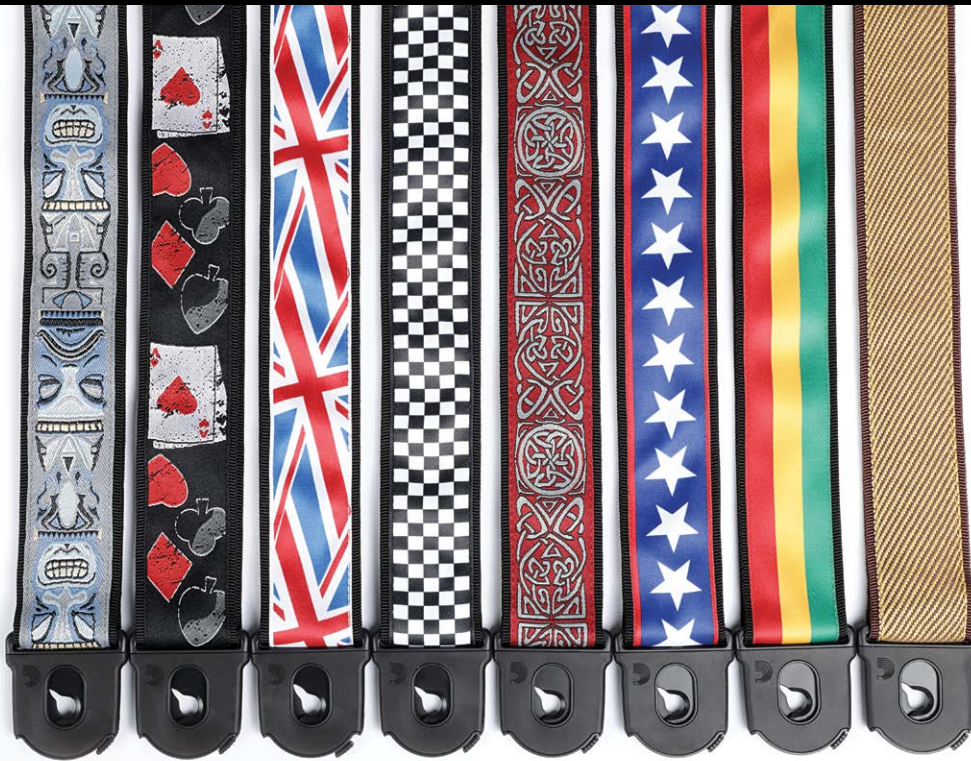

Planet Lock™ Straps

The patented design of Planet Lock fits virtually all end pins and stays locked in place until you release the side pin. Unlike ordinary strap lock systems, Planet Lock is designed to fit securely on your guitar's existing end pin. Planet Lock is safe, secure, easy to use, and available in our most popular designs.

Item #	Description	Retail
50PLA02	Tiki	\$40.90
50PLD01	Hold 'Em	\$40.90
50PLA11	Union Jack	\$40.90
50PLC02	Checkmate	\$40.90
50PLA07	Celtic	\$40.90
50PLA10	Stars & Stripes	\$40.90
50PLA06	Jamaica	\$40.90
50PLB06	Tweed	\$40.90



Item #	Description	Retail
50PLF03	Crosses	\$40.90
50PLA04	Barbed Wire	\$40.90
50PLA12	Voodoo	\$40.90
50PLC01	Rock Star	\$40.90
50PLB01	Black Satin	\$40.90
50PLF06	Tribal	\$40.90
50PLA05	Black Nylon	\$40.90
50PLL00	Black Leather	\$66.55
50CTPL00	Black Cotton	\$27.70

ACOUSTIC & PADDED STRAPS



Straps with Shoulder Pads

Our most popular woven strap designs are now available with a built-in shoulder pad to provide greater comfort while also allowing the strap to slide with the movement of the player.

Item #	Description	Retail
50PLA12-PD	Voodoo	\$42.35
50B01-PD	Black Satin	\$38.05
50E03-PD	Saugerties	\$38.05
50A11-PD	Union Jack	\$38.05
50PLA05-PD	Black	\$42.35



Acoustic Quick Release™ Straps

D'Addario Acoustic Quick Release Straps eliminate the need to tie and untie knots. Attach the loop-through end of the Acoustic Quick Release to the headstock and attach the standard end to the strap pin. Simply unclip the quick release latch to remove your strap. US Patent # 5,868,293

Item #	Description	Retail
50PAF05	Classic Black	\$39.75
50PAC08	Monterey	\$39.75
PWSPA209	Brown	\$14.85
PWSPA202	Blue	\$14.85
PWSPA200	Black	\$15.55

LEATHER STRAPS



Item #	Description	Retail
25VNER01-DX	Embossed Studded Brown	\$62.55
L25S1500	Snake Window	\$88.55
25SNK-01	Python	\$66.55
L25W1501	Decorative Stitch	\$87.35
25ALI-01	Alligator Embossed	\$66.55
L25S1501	Braided	\$120.25



**TOP★
SELLER**

Item #	Description	Retail
25SSC00	Conchos - Black	\$60.75
25SSC01	Conchos - Brown	\$60.75
★ 25LBB00	Black Belt Buckle	\$62.55
25PRF05	Vented - Honey Apache	\$65.25
25PRF04	Vented - Camel Rosettes	\$65.25

LEATHER STRAPS

Vented & Perforated Leather

Item #	Description	Retail
25PRF01	Vented - Black Rows	\$65.25
L25W1502	Perforated - White Flowers	\$84.75
25PRF02	Vented - Brown Diamonds	\$65.25



Embossed Leather

Item #	Description	Retail
L25W1403	Embossed Flowers - Black	\$112.35
L25W1404	Embossed Weave - Brown	\$112.35
25WSTB00	Basket Weave - Black	\$57.00
25WSTE01	Western Eagle Embossed - Brown	\$57.00
25LE00	Embossed - Black	\$66.30
25LE01	Embossed - Brown	\$66.30



**TOP
SELLER**



Blasted & Thick Garment Leather

Item #	Description	Retail
25VNR00-DX	Blasted w/ Brass Rivets (Rows) - Black	\$53.15
25VNR01-DX	Blasted w/ Brass Rivets (Diamond) - Brown	\$53.15
25VN01-DX	Blasted Brown	\$53.15
25TL00-DX	Garment Thick Leather - Black	\$86.50
25TL01-DX	Garment Thick Leather - Brown	\$86.50



Stonewashed & Soft Garment Leather

Item #	Description	Retail
25VNS00-DX	Stonewashed Contrast Stitch - Black	\$53.15
25VNS01-DX	Stonewashed Contrast Stitch - Brown	\$53.15
25SL00-DX	Garment Soft Leather - Black	\$70.50
25SL01-DX	Garment Soft Leather - Brown	\$70.50

**TOP★
SELLER**



LEATHER STRAPS



Basic Colored Leather

Item #	Description	Retail
25BL03	Red	\$25.30
25BL04	Blue	\$25.30
25BL02	White	\$25.30
25BL01	Brown	\$25.30
★ 25BL00	Black	\$25.30

TOP★
SELLER



Suede Leather

Item #	Description	Retail
25SS01-DX	Cognac	\$53.15
25SS03-DX	Burgundy	\$53.15
25SS00-DX	Black	\$53.15
25SS02-DX	Honey	\$53.15

TOP★
SELLER



Classic Leather

Item #	Description	Retail
25LS01-DX	Contrast Stitch - Brown	\$39.95
25LS00-DX	Contrast Stitch - Black	\$39.95
25L01-DX	Brown	\$30.70
25L00-DX	Black	\$30.70
25L00-DXXL	Black, Extra Long (not shown)	\$39.95



2" Suede Leather

Item #	Description	Retail	Item #	Description	Retail
20SD00	Silver Snakeskin	\$111.15	20SD04	Cork	\$111.15
20SD07	Embossed - Brown	\$111.15	20SD05	Cork Weave	\$111.15
20SD06	Embossed - Black	\$111.15	20LE03	Embossed Dots	\$111.15
20LE02	Quilted Yellow	\$111.15			



Reversible!



Wool padding
for comfort

Comfort Leather

Item #	Description	Retail
25L00-SS	Padded Leather Sheepskin	\$53.35
20PLC00-DX	Padded Leather - Black Piping	\$111.75
25RVP01-DX	Reversible Comfort Suede - Brown/Black	\$70.50

LEATHER STRAPS



NYXL Strap

Now players can show off their loyalty to NYXL guitar strings with this new, sleek-looking NYXL Guitar Strap. This guitar strap features "Eco-Leather," a repurposed leather material made with a standard leather-style length adjuster and embroidered NYXL branding.

Item #	Retail
20NYXL01	\$54.25



**TOP★
SELLER**

Black & White Leather

Item #	Description	Retail
25LIC03	Lightning	\$44.00
L25W1500	Tribal Tattoo	\$70.90
★ 25LIC01	Music Notes	\$44.00



Laced & Studded Leather

Item #	Description	Retail
L25S1502	Strings & Studs	\$88.55
L25S1504	Laced - Black	\$94.95
L25S1505	Laced - White	\$94.95
L25S1503	Hex Studs	\$94.94
25LGS02	Grommets	\$57.30
25LGS01	Diamond Studs	\$60.30



NEW! Hybrid Leather Strap

The D'Addario Hybrid Leather Strap combines the strength and quality of a leather strap with the easy adjustability of a woven strap. Each strap features an Eco-Leather top and matching strap end (repurposed leather), backed with "Super Suede" (synthetic suede), and a polypropylene woven end with a brushed die-cast zinc adjuster.

- Leather strap with the easy adjustability of a woven strap
- Eco-Leather top with super suede backing
- Strong polypropylene material with brushed die-cast zinc hardware
- Adjustable from 44" - 56"

Item #	Retail
25HYB00	\$58.50

NEW! Reversible Leather Straps

D'Addario Reversible Leather Straps give two strap styles in one. Sold in a variety of colors, each strap is 3-ply garment leather and adjustable from 41" - 60".

- 2 color-way straps offer 2 styles in 1
- 3-ply garment leather
- Precision accent stitching
- Adjustable from 41" - 60"

Item #	Description	Retail
25REV00	Black/Red	\$129.90
25REV01	Black/White	\$129.90
25REV02	Black/Brown	\$129.90
25REV03	Black/Brown Suede	\$129.90



Premium Leather Straps

D'Addario Premium Leather Straps take guitar strap quality to the next level. Made from the highest quality of leather, this line of straps uses precision stitching and cut-out designs that not only look great but feel great. Each strap is padded for comfort and adjustable from 49"-58". Made in the USA.

Item #	Description	Retail
25PRL00	Onyx	\$354.40
25PRL02	Crimson Burst	\$354.40
25PRL01	Rustic Cutout	\$354.40

STRAP INNOVATIONS



NEW! Universal Strap Locks

D'Addario's Universal Strap Locks, designed by Ned Steinberger, give you the certainty and peace of mind that your instrument and strap are firmly locked in place. With hassle-free installation, our strap locks make it quick and easy to connect and remove your strap, leaving you free to move about the stage with confidence. Strap Buttons are available in black, gold and nickel.

- Complete strap security
- Tool-free installation
- Strap buttons available in 3 colors

Item #	Description	Retail
PW-SLS-01	Black	\$38.65
PW-SLS-02	Nickel	\$36.55
PW-SLS-03	Gold	\$40.75



NEW! Dual-Lock Strap Locks

The D'Addario Dual-Lock Strap Lock provides a low-cost alternative to strap security for additional instrument protection. Without need of modification, the Dual-Lock clips onto your existing strap button to prevent your strap from releasing accidentally. Additionally, the Dual-Lock can be clipped onto your instrument cable, securing your cable to your instrument to prevent the plug from being pulled unintentionally from the input jack. D'Addario Dual-Lock Strap Lock – protecting your instrument and your performance.

- Sold in pairs (30 pairs per fishbowl*)
- Secures both the strap and instrument cable
- Cost effective solution to strap security

Item #	Description	Retail
PW-DLC-01	Black	\$4.70
PW-DLC-30	Fishbowl (30 ct)	\$4.55*

*Must be ordered in quantities of 30.
Retail value \$141.00

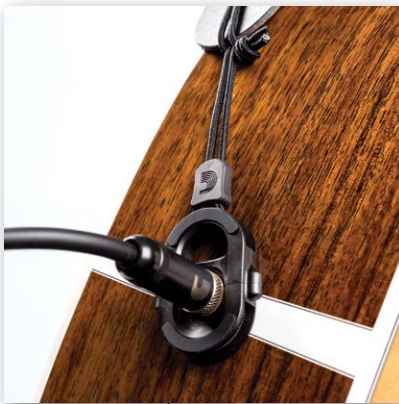

Acoustic Cinch Fit

The Acoustic Cinch Fit is the fast-and-easy way to attach your strap to electric acoustic guitars with endpin output jacks. Endpin jacks are notorious for creating hassles when applying and removing standard guitar straps, and usually require modification to the strap which results in a less-than-desirable fit.

The Acoustic Cinch Fit loops through the end of any instrument strap. Its cinch clamping action allows easy application and removal, utilizing the weight of the instrument to remain locked onto the endpin so your guitar is always held securely.

- Securely attach any strap to acoustic endpin jacks
- Easy application and removal
- No strap modification required

Item #	Retail
PW-AJL-01	\$19.05

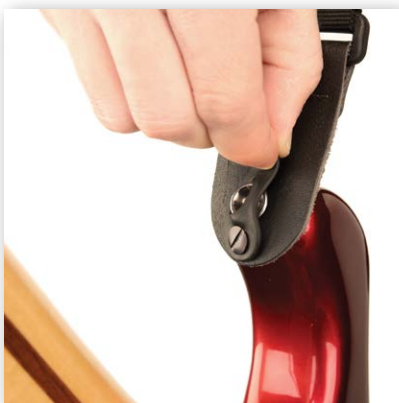

Pad Lock Guitar Strap

The Pad Lock Guitar Strap is the latest in strap lock innovation. Simply put the strap on your guitar and pull the attached rubber tab over the guitar's end pin and that's it. This strap was inspired by an old technique of placing rubber washers between the strap and end pin. The Pad Lock Guitar Strap requires no extra parts or hardware.

- Secured rubber locking tabs on both strap ends
- No need for additional locking hardware
- 2" black tubular nylon material
- Adjustable length from 35" - 56"

Patent pending

Item #	Retail
50F05-RL	\$35.75





TOP★SELLER

Acoustic Quick Release™ System

The Acoustic Quick Release System takes just seconds to set up, won't come loose while playing, and the extra length of the cord keeps the guitar strap's webbing from interfering with the guitarist's hand when playing near the headstock. Best of all, just squeeze the quick release and you're free – no knots!

US Patent #5,868,293

Item #	Retail
DGS15	\$8.20



Gel Guitar Strap Shoulder Pad

The Gel Guitar Strap Shoulder Pad makes use of a revolutionary gel that transforms your favorite strap into a comfortable, stress-relieving solution for even the heaviest instruments. Thanks to a secure hook-and-loop attachment system, the Gel Guitar Strap Shoulder Pad is interchangeable between multiple guitars and straps in an instant! Fits most manufacturer's woven straps.

Item #	Retail
PW-GSP	\$27.70



Air Cell Guitar Strap Shoulder Pad

The Air Cell Guitar Strap Shoulder Pad slides over most popular fabric straps for quick relief of playing discomfort. Fits most manufacturer's woven straps!

Item #	Retail
PW-FSP-1	\$24.05



31" Leather Strap Extender

Converts any leather strap to super long.

Item #	Retail
LSE-XL	\$13.35



Dare™ Strap

D'Addario teamed up with product designer Troy Dare to bring you the patented Dare Strap. Unlike conventional straps, the patented Dare Strap allows you to spread the weight of your instrument over both shoulders instead of only one. Great for heavy instruments and players with back or neck conditions.

Patent #6,581,812

Item #	Retail
SODARE000	\$33.25

SIGNATURE STRAPS



Joe Satriani Signature Strap Collection

The JS Collection was designed in partnership with legendary guitarist Joe Satriani. The original art pulled directly from Joe's personal sketchbooks or inspired by his guitars. Known as a guitar innovator with 13 Grammy® nominations and over 10 million copies of his albums and DVDs sold around the world, Joe has achieved huge success in his more than 20-year career. His love for character sketching has yielded volumes of original artwork, available to the public in JS Series straps and picks from D'Addario.



JS Silver Embossed Leather

Item #	Description	Retail
25LS-JS1	Frog Man	\$49.20
25LS-JS2	Gray Man	\$49.20

These straps just turned out looking and feeling so great, it puts a smile on my face every time I pick up the guitar.

Joe Satriani



		Skulls n' Bones	Up in Flames	Snakes	Souls of Distortion	Drops	Silver Sketches	Skulls	Spaceman	Ghost	Relic
	Retail	Item #	Item #	Item #	Item #	Item #	Item #	Item #	Item #	Item #	Item #
Leather End	\$40.90	50JS01	50JS02	50JS04	50JS03	50JS10	50JS05	50JS07	50JS06	50JS11	50JS09
Planet Lock	\$44.20	50PLJS01	50PLJS02								

THE BEATLES

NEW! The Beatles™ Black Poly-pro Guitar Strap

D'Addario combines the classic black polypropylene guitar strap with embroidered art of "The Beatles" iconic logo.

- Classic black polypropylene
- Embroidered "The Beatles" logo
- Adjustable from 34" - 59"



Item #	Retail
PWSBT100	\$21.70

NEW! The Beatles™ "Sgt. Pepper's Lonely Hearts Club Band" 50th Anniversary Collection

On June 1st, 1967, The Beatles released what was arguably one of the best rock albums of all time - "Sgt. Pepper's Lonely Hearts Club Band". Now, 50 years later, D'Addario is adding a 2 guitar strap and guitar pick collection to The Beatles music accessory product line to celebrate this historic album. Available for a limited time only.

- Woven: printed polyester with nylon ends
- Vegan: vinyl strap w/ "leather strap styled" adjuster

Item #	Description	Retail
50BTL09	50th Anniversary Sgt. Pepper - Woven	\$40.95
25LB09	50th Anniversary Sgt. Pepper - Vegan	\$67.60



The Beatles™ Signature Strap Collection

From *Love Me Do* to *Revolution*, The Beatles were arguably the most creative, diverse and influential band in pop music history. D'Addario honors The Beatles' legacy with a unique collection of guitar straps, featuring iconic album covers and timeless images which capture the enduring spirit and essence of the "Fab Four."



Woven Straps

Item #	Description	Retail
50BTL05	White Album	\$40.90
50BTL01	Classic Logo	\$40.90
50BTL02	Beatlemania	\$40.90
50BTL06	Revolution	\$40.90
50BTL00	Sgt. Pepper	\$40.90

Vegan Straps

Item #	Description	Retail
25LB01	Meet The Beatles	\$67.60
25LB06	Yellow Submarine	\$67.60
25LB05	Sgt. Pepper	\$67.60
25LB04	Revolver	\$67.60
25LB00	Sgt. Pepper	\$67.60

SIGNATURE STRAPS



Alchemy Gothic™ Strap Collection

Since 1977 Alchemy Gothic™ has been the leader in gothic jewelry, art, and lifestyle products. Designed and produced in their Leicester, England workshops, Alchemy Gothic has amassed an incredible collection of authentic gothic, mythology, and fantasy art now featured on this officially licensed strap collection. Express your dark side!



Woven Straps

Item #	Description	Retail
50AL01	Muted Skulls	\$40.90
50AL05	Gods of War	\$40.90
50AL06	Rogues Gallery	\$40.90
50AL02	Gothic Crosses	\$40.90



Leather Straps

Item #	Description	Retail
25LAL01	Blackbloods Skull	\$59.95
25LAL02	Dead Draw	\$59.95

Pat Metheny Woven Strap Collection

From the mind of jazz great Pat Metheny comes an exciting strap collection. Hailed by countless polls as "Best Jazz Guitarist," and known as the artist that brought jazz music to the masses, Pat and D'Addario bring these exciting strap designs to you.

Item #	Description	Retail
50PM01	Travels	\$40.90
50PM02	Watercolors	\$40.90



OTHER INSTRUMENT STRAPS



NEW! Eco-Comfort Ukulele Straps

The D'Addario Ukulele Strap line is an eco-friendly soundhole hook style strap made specifically to support all ukuleles with a standard soundhole. The full line is made from an eco-friendly fabric, made from recycled water bottles, and is super comfortable while also being super durable with a color scheme inspired by beach elements. The hook is made from a soft rubber that will not harm or scratch your ukulele but is strong enough to support the weight of the instrument.

- Soft and durable eco-friendly strap material made from recycled plastic bottles
- Soundhole hook made from soft rubber
- 5 beach-inspired color designs

Item #	Description	Retail
19UKE02	Stone	\$52.45
19UKE04	Coral	\$52.45
19UKE00	Black	\$52.45
19UKE01	Sand	\$52.45
19UKE03	Seafoam	\$52.45



Small Instrument Straps

Item #	Description	Retail
15UKE00	1.5" Jacquard - Aloha Design	\$23.90
15UKE01	1.5" Jacquard - Flower 1 Design	\$23.90
15UKE02	1.5" Jacquard - Flower 2 Design	\$23.90
PWSUKE301	1.5" Poly Pro - Red	\$10.05
PWSUKE300	1.5" Poly Pro - Black	\$10.05
PWSUKE302	1.5" Poly Pro - Blue	\$10.05

TOP ★
SELLER



Banjo Straps

D'Addario offers a variety of banjo straps. Styles range from cradle style with a choice of leather to nylon with non-marring clips.

Item #	Description	Retail	Item #	Description	Retail
20N00BJ	Hootenanny - Red & Silver	\$22.15	25SLBNJ02-DX	Garment Leather w/coated metal hooks	\$95.20
20N01BJ	Hootenanny - Yellow & Brown	\$22.15	50BNJ000	Nylon Banjo Strap - Black	\$22.15
25LBNJ00-DX	Classic Leather - Black	\$59.95			

OTHER INSTRUMENT STRAPS



3" Wide Guitar/Bass Straps

74T is a 3" (74mm) wide tubular strap with an internal pad. Perfect for heavy bass guitars.

Item #	Description	Retail
74T000	Black	\$35.75
74T001	Red	\$34.70
74T002	Blue	\$35.75

75B is a 3" (75mm) basic wide strap made of polypropylene.

Item #	Description	Retail
75B000	Black	\$30.90
75B001	Red	\$30.90
75B002	Blue	\$30.90

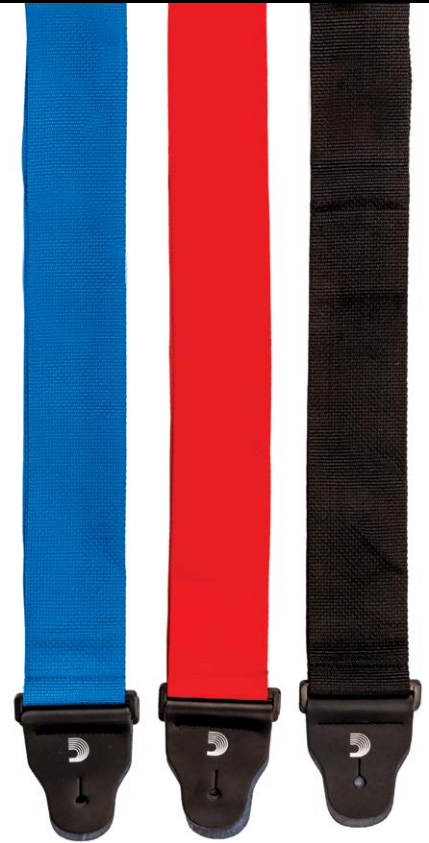

Classical Guitar Strap

The 2" wide nylon classical strap is fully adjustable and features a non-marring soundhole hook. Available in black only.

Item #	Description	Retail
50CL000	Black Nylon	\$16.30
20T01CL	Black Satin	\$33.25



Mandolin Straps

D'Addario Mandolin Straps are 3/4" wide and made with premium leathers that are safe for all mandolin finishes.

Item #	Description	Retail
75M00	Black	\$26.60
75M01	Brown	\$26.60



THE BEATLES

The Beatles™ Signature Pick Collection

From *Love Me Do* to *Revolution*, The Beatles were arguably the most creative, diverse and influential band in pop music history. D'Addario honors The Beatles' legacy with a unique collection of guitar picks, featuring iconic album covers and timeless images which capture the enduring spirit and essence of the "Fab Four."

	Format	Retail	Description	Light Gauge Item #	Medium Gauge Item #	Heavy Gauge Item #
NEW!	10-pack	\$11.95	Sgt. Pepper 50th	1CWH2-10B6	1CWH4-10B6	1CWH6-10B6
	10-pack	\$11.95	Revolver	1CWH2-10B1	1CWH4-10B1	1CWH6-10B1
	10-pack	\$11.95	Meet The Beatles	1CBK2-10B2	1CBK4-10B2	1CBK6-10B2
	10-pack	\$11.95	Albums	1CWH2-10B3	1CWH4-10B3	1CWH6-10B3



Format	Retail	Item #	Description	Gauge
15-pick Tin	\$14.95	1CAB4-15BT3	Sgt. Pepper	Medium
15-pick Tin	\$14.95	1CAB4-15BT2	Stripes Tin	Medium
15-pick Tin	\$14.95	1CAB4-15BT1	Logo Tin	Medium



NEW! Keith Urban Signature Guitar Picks

Put to the test on stage and in the studio, the Keith Urban Signature Guitar Pick is designed in partnership by D'Addario and Keith Urban to capture superior and versatile tone. Made from a custom Ultem blend, this pick features three distinct playing surfaces: a standard, pointed tip; a rounded smooth tip for warmer tone; and a textured rounded tip for a harmonically edgier tone. Available in medium, heavy, and extra heavy thicknesses.

Format	Retail	Item #	Description	Gauge
5-pack	\$17.30	1UKU4-05	Bone	Medium
5-pack	\$17.30	1UKU6-05	Gray	Heavy
5-pack	\$17.30	1UKU7-05	Black	Extra Heavy



Joe Satriani Signature Pick Collection

JS Design picks are made of premium celluloid and are available in white with black printing or black with silver printing. Each 10-pack includes 1 each of 10 different original Joe Satriani Designs.

The JS Chrome Dome pick is made of stainless steel and packaged with four regular JS designed picks.



			Light Gauge .018in (.46mm)	Medium Gauge .028in (.71 mm)	Heavy Gauge .038in (.96 mm)
Format	Retail	Description	Item #	Item #	Item #
10-pack	\$11.80	Silver on Black	1CBK2-10JS	1CBK4-10JS	1CBK6-10JS
10-pack	\$11.80	Black on White	1CWH2-10JS	1CWH4-10JS	1CWH6-10JS
Format	Retail	Description	Item #		
1-pack	\$11.65	Chrome Dome	JSCD-01		

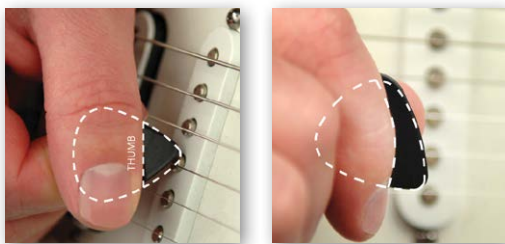

Pick Rite™

- Ensures proper finger placement for optimum picking
- Builds speed, dexterity, and accuracy
- Ends the frustration of pick slippage for beginners
- For right-handed guitarists

Item #	Retail
1RBK4-5R	\$7.05



Pick Holder

The D'Addario Pick Holder holds up to 5 medium-heavy gauge picks, and the included hook-and-loop tab makes it easy to attach to any surface so you always have picks nearby.

Item #	Retail
PW-PH-01	\$5.35



Mic Stand Pick Holder

The D'Addario Mic Stand Pick Holder features not one but two pick holding channels to fit twice the amount of picks as the competitors in the same space. The holder attaches easily to any microphone stand so you always have plenty of picks on hand.

- Holds 10 standard-shape picks
- Two channels for pick storage
- Clips onto any microphone stand

Item #	Retail
PW-MPH-01	\$11.95



Mic Stand Pick Holder Fish Bowl

D'Addario's two-channel Mic Stand Pick Holder now in a short cut, 2-inch version. Holds up to 4 standard-sized guitar picks.

Item #	Retail
PW-MMPH-01	\$5.65*

*Must be ordered in increments of 30. Retail value of \$169.50



Black rubber pick with 3 different inserts – choose your gauge

Adjustable Insert Pick

- Customizable solution to achieve a variety of picking sounds and attacks
- The perfect tool to obtain finger-plucked sound on bass or electric guitar
- Can be used on any stringed instrument

Item #	Format	Retail
PW-IP	1 pack	\$7.05

Pick Holder with LED Light

- Holds up to 4 medium gauge (.71mm) picks
- Bright blue LED light illuminates dark settings
- Keychain design keeps picks on hand
- Runs on 2 CR1616 3V batteries (included)

Item #	Retail
PW-LED-01	\$10.75



Canadian Picks

Red pearl celluloid picks which feature a white maple leaf. Single sided. Medium gauge. 100 pcs.

Item#	Retail
SP-1EH	\$50.25



Fleur De Lis Picks

Blue pearl celluloid picks which feature a white Fleur De Lis. Single sided. Medium gauge. 100 pcs.

Item#	Retail
SP-1FDL	\$50.25



Finger & Thumb Picks

D'Addario classic shell color celluloid Finger & Thumb Picks are produced from the highest quality celluloid and offer consistency and durability that is unmatched.

Thumb Picks			
Format	Retail	Description	Item #
5-pack	\$5.80	Medium Thumb Pick	5CSH4-5
50-pack	\$58.15	Medium Thumb Pick	5CSH4-50
5-pack	\$5.80	Large Thumb Pick	5CSH6-5
50-pack	\$58.15	Large Thumb Pick	5CSH6-50



Finger Picks			
Format	Retail	Description	Item #
5-pack	\$5.80	Medium Finger Pick	4CSH4-5
50-pack	\$58.15	Medium Finger Pick	4CSH4-50
5-pack	\$5.80	Large Finger Pick	4CSH6-5
50-pack	\$58.15	Large Finger Pick	4CSH6-50

CELLULOID PICKS

One of the first polymers ever created, cellulose nitrate is made by reacting cotton fibers with nitric acid. Used for more than a century as the base for movie and 35mm film, celluloid was substituted for natural tortoise shell picks in the early 1900s. Still one of the most popular pick materials available today, they are available in a variety of thicknesses, shapes, and colors, and provide a natural feel with warm, fat tone.

Classic Celluloid Picks

Standard and Wide Shapes



Format	Retail	Description	Black Celluloid Item #	Multi-Color Celluloid Item #	Shell Celluloid Item #	White Celluloid Item #	White Pearl Celluloid Item #	Camouflage Celluloid Item #	Rainbow Celluloid Item #	Checker Celluloid Item #	Cellu-Glo Celluloid Item #
10-pack	\$5.35	Light Gauge	1CBK2-10	1CMC2-10	1CSH2-10	1CWH2-10	1CWP2-10	1CCF2-10	1CRB2-10	1CCB2-10	1CCG2-10
25-pack	\$11.80	Standard Shape	1CBK2-25	1CMC2-25	1CSH2-25	1CWH2-25	1CWP2-25	1CCF2-25	1CRB2-25	1CCB2-25	1CCG2-25
100-pack	\$41.55	.020in (.50 mm)	1CBK2-100	1CMC2-100	1CSH2-100	1CWH2-100	1CWP2-100	1CCF2-100	1CRB2-100	1CCB2-100	1CCG2-100
10-pack	\$5.35	Medium Gauge	1CBK4-10	1CMC4-10	1CSH4-10	1CWH4-10	1CWP4-10	1CCF4-10	1CRB4-10	1CCB4-10	1CCG4-10
25-pack	\$11.80	Standard Shape	1CBK4-25	1CMC4-25	1CSH4-25	1CWH4-25	1CWP4-25	1CCF4-25	1CRB4-25	1CCB4-25	1CCG4-25
100-pack	\$41.55	.028in (.70 mm)	1CBK4-100	1CMC4-100	1CSH4-100	1CWH4-100	1CWP4-100	1CCF4-100	1CRB4-100	1CCB4-100	1CCG4-100
10-pack	\$5.35	Heavy Gauge	1CBK6-10	1CMC6-10	1CSH6-10	1CWH6-10	1CWP6-10	1CCF6-10	1CRB6-10	1CCB6-10	1CCG6-10
25-pack	\$11.80	Standard Shape	1CBK6-25	1CMC6-25	1CSH6-25	1CWH6-25	1CWP6-25	1CCF6-25	1CRB6-25	1CCB6-25	1CCG6-25
100-pack	\$41.55	.039in (1.0 mm)	1CBK6-100	1CMC6-100	1CSH6-100	1CWH6-100	1CWP6-100	1CCF6-100	1CRB6-100	1CCB6-100	1CCG6-100
10-pack	\$5.35	Extra Heavy Gauge	1CBK7-10	1CMC7-10	1CSH7-10	1CWH7-10	1CWP7-10	1CCF7-10	1CRB7-10	1CCB7-10	1CCG7-10
25-pack	\$11.80	Standard Shape	1CBK7-25	1CMC7-25	1CSH7-25	1CWH7-25	1CWP7-25	1CCF7-25	1CRB7-25	1CCB7-25	1CCG7-25
100-pack	\$41.55	.049in (1.25 mm)	1CBK7-100	1CMC7-100	1CSH7-100	1CWH7-100	1CWP7-100	1CCF7-100	1CRB7-100	1CCB7-100	1CCG7-100
10-pack	\$6.55	Light Gauge	2CBK2-10	2CMC2-10	2CSH2-10	2CWH2-10	2CWP2-10				
25-pack	\$14.70	Wide Shape	2CBK2-25	2CMC2-25	2CSH2-25	2CWH2-25	2CWP2-25				
100-pack	\$51.90	.020in (.50 mm)	2CBK2-100	2CMC2-100	2CSH2-100	2CWH2-100	2CWP2-100				
10-pack	\$6.55	Medium Gauge	2CBK4-10	2CMC4-10	2CSH4-10	2CWH4-10	2CWP4-10				
25-pack	\$14.70	Wide Shape	2CBK4-25	2CMC4-25	2CSH4-25	2CWH4-25	2CWP4-25				
100-pack	\$51.90	.028in (.70 mm)	2CBK4-100	2CMC4-100	2CSH4-100	2CWH4-100	2CWP4-100				
10-pack	\$6.55	Heavy Gauge	2CBK6-10	2CMC6-10	2CSH6-10	2CWH6-10	2CWP6-10				
25-pack	\$14.70	Wide Shape	2CBK6-25	2CMC6-25	2CSH6-25	2CWH6-25	2CWP6-25				
100-pack	\$51.90	.039in (1.0 mm)	2CBK6-100	2CMC6-100	2CSH6-100	2CWH6-100	2CWP6-100				
10-pack	\$6.55	Extra Heavy Gauge	2CBK7-10	2CMC7-10	2CSH7-10	2CWH7-10	2CWP7-10				
25-pack	\$14.70	Wide Shape	2CBK7-25	2CMC7-25	2CSH7-25	2CWH7-25	2CWP7-25				
100-pack	\$51.90	.049in (1.25 mm)	2CBK7-100	2CMC7-100	2CSH7-100	2CWH7-100	2CWP7-100				

Pearl Celluloid Picks

Standard Shape

Format	Retail	Description	Red Pearl Celluloid Item #	Green Pearl Celluloid Item #	Blue Pearl Celluloid Item #	Black Pearl Celluloid Item #	White Pearl Celluloid Item #
10-pack	\$5.35	Light Gauge	1CRP2-10	1CGP2-10	1CBUP2-10	1CBKP2-10	1CWP2-10
25-pack	\$11.80	Standard Shape	1CRP2-25	1CGP2-25	1CBUP2-25	1CBKP2-25	1CWP2-25
100-pack	\$41.55	.020in (.50 mm)	1CRP2-100	1CGP2-100	1CBUP2-100	1CBKP2-100	1CWP2-100
10-pack	\$5.35	Medium Gauge	1CRP4-10	1CGP4-10	1CBUP4-10	1CBKP4-10	1CWP4-10
25-pack	\$11.80	Standard Shape	1CRP4-25	1CGP4-25	1CBUP4-25	1CBKP4-25	1CWP4-25
100-pack	\$41.55	.028in (.70 mm)	1CRP4-100	1CGP4-100	1CBUP4-100	1CBKP4-100	1CWP4-100
10-pack	\$5.35	Heavy Gauge	1CRP6-10	1CGP6-10	1CBUP6-10	1CBKP6-10	1CWP6-10
25-pack	\$11.80	Standard Shape	1CRP6-25	1CGP6-25	1CBUP6-25	1CBKP6-25	1CWP6-25
100-pack	\$41.55	.039in (1.0 mm)	1CRP6-100	1CGP6-100	1CBUP6-100	1CBKP6-100	1CWP6-100
10-pack	\$5.35	Extra Heavy Gauge	1CRP7-10	1CGP7-10	1CBUP7-10	1CBKP7-10	1CWP7-10
25-pack	\$11.80	Standard Shape	1CRP7-25	1CGP7-25	1CBUP7-25	1CBKP7-25	1CWP7-25
100-pack	\$41.55	.049in (1.25 mm)	1CRP7-100	1CGP7-100	1CBUP7-100	1CBKP7-100	1CWP7-100

Pearl Celluloid Assortments

Includes each color pearl celluloid pick.

Item #	Description	Retail	Item #	Description	Retail
1CAP2-10	Light - 10-pack	\$5.35	1CAP6-10	Heavy - 10-pack	\$5.35
1CAP2-25	Light - 25-pack	\$11.80	1CAP6-25	Heavy - 25-pack	\$11.80
1CAP2-100	Light - 100-pack	\$41.55	1CAP6-100	Heavy - 100-pack	\$41.55
1CAP4-10	Medium - 10-pack	\$5.35	1CAP7-10	XHeavy - 10-pack	\$5.35
1CAP4-25	Medium - 25-pack	\$11.80	1CAP7-25	XHeavy - 25-pack	\$11.80
1CAP4-100	Medium - 100-pack	\$41.55	1CAP7-100	XHeavy - 100-pack	\$41.55

NEW! Acrylux Picks: Reso & Nitra

D'Addario has a wide variety of pick types, and now introduced to the assorted materials is the Acrylux series. Acrylux is available in 2 blends (Reso and Nitra) to offer two distinct tones while providing the grip and output that is expected of acrylic picks. Available in standard, jazz, and mandolin shapes in 1.5mm thickness sold in 3-packs and 25-pick bulk packs for "per pick" sales.



Acrylux Reso Picks

Translucent Red

- Pure acrylic
- Brighter tone
- Strong output and grip
- Transparent red



Acrylux Nitra Picks

Black Pearl

- Blended acrylic and nitrate
- Warmer tone
- Strong output and grip
- Black pearl



Format	Retail	Reso Standard Item #	Nitra Standard Item #	Reso Jazz Item #	Nitra Jazz Item #
3-pack	\$16.25	1AR7-03	1AN7-03	3AR7-03	3AN7-03
25-pack	\$97.65	1AR7-25	1AN7-25	3AR7-03	3AN7-25

Format	Retail	Reso Mandolin Item #	Nitra Mandolin Item #
3-pack	\$16.25	2AR7-03	2AN7-03
25-pack	\$97.65	2AR7-25	2AN7-25

NEW! Ukulele Felt Picks

Traditional picks produce a harsh tone on the ukulele, which is why felt has been the go-to material for ukulele picks for years. The D'Addario Ukulele Felt Pick creates that same warm tone with more projection, while the elliptical cutout provides extra grip and flexibility. In addition to ukulele, these picks are excellent alternatives to finger plucking on bass guitar.



- 3.0mm thickness
- Felt material for warm tone
- Elliptical cutout for grip and flexibility
- Available in packs of (4) and (25)

Retail	Description	Item #
\$10.85	4-pack	1FLT9-04
\$54.25	25-pack	1FLT9-25

Nylpro Picks

The Nylpro jazz-shaped nylon pick provides a warm tone while the sharp tip radius allows for greater articulation, speed, and control. The polished tip allows the pick to glide effortlessly across the strings while the textured top provides excellent grip and control. Perfect for intricate playing styles such as jazz, progressive rock, and shred.

Format	Gauge	Item #	Retail
10-pack	1.4mm	3NPR7-10	\$5.35
25-pack	1.4mm	3NPR7-25	\$11.80
100-pack	1.4mm	3NPR7-100	\$41.55



Nylpro Plus Picks

The Nylpro Plus is an injected molded nylon and fiberglass jazz pick. By adding fiberglass to the pick, the Nylpro Plus provides a brighter tone and harder texture for extra control, while maintaining the same size, shape, and feel of our standard Nylpro jazz pick.

Format	Gauge	Item #	Retail
10-pack	1.4mm	3NPP7-10	\$5.35
25-pack	1.4mm	3NPP7-25	\$11.80
100-pack	1.4mm	3NPP7-100	\$41.55



Nylflex Picks

Inspired by the revered nylon picks of the 50s and 60s, the D'Addario Nylflex is the first nylon pick to capture the flexible feel, warm tone, and molded grip pattern of the original – delivering an authentic, vintage-playing experience in its entirety. Now you can finally experience the feel and tone that was so eagerly sought out by Hall of Fame guitarists during the birth of rock-n-roll. Nylflex – the modern pick for vintage tone!



		Light Gauge .029in (.50mm)	Medium Gauge .029in (.75mm)	Heavy Gauge .039in (1.00 mm)
Format	Retail	Item #	Item #	Item #
10-pack	\$5.35	1NFX2-10	1NFX4-10	1NFX6-10
25-pack	\$11.80	1NFX2-25	1NFX4-25	1NFX6-25
100-pack	\$41.55	1NFX2-100	1NFX4-100	1NFX6-100

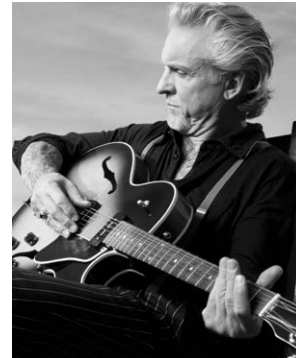

The classic design and sound of Nylflex picks give me exactly what I need to get my desired tone.

**Neil "Spyder" Giraldo,
Pat Benatar**



Cortex Picks

Cortex Picks are precision-molded to eliminate grain structures, allowing for dynamic pick response. This unique material closely resembles actual tortoise shell in feel and sound yet offers high strength, durability, and heat resistance. Cortex long-lasting picks offer excellent attack with a clean, crisp tone for superior note definition, allowing notes to leap from your strings. Attack, control, clarity, and durability...Cortex Picks!

- Long lasting, durable material
- Superior note definition
- For excellent speed and control

		Light Gauge .020in (.50mm)	Medium Gauge .028in (.70mm)	Heavy Gauge .039in (1.00mm)	Extra Heavy .049in (1.25mm)
Format	Retail	Item #	Item #	Item #	Item #
10-pack	\$8.90	1UCT2-10	1UCT4-10	1UCT6-10	1UCT7-10
25-pack	\$22.55	1UCT2-25	1UCT4-25	1UCT6-25	1UCT7-25
100-pack	\$88.95	1UCT2-100	1UCT4-100	1UCT6-100	1UCT7-100

Variety Guitar Pick Pack

The Variety Guitar Pick Pack features a pick from each of our pick material line-ups as well as additional shapes. Each pack contains Celluloid, Nylflex, Nylpro, Cortex, Delrin, Black Ice, and Duragrip. Find the pick that best suits you!

- 7 pack of picks featuring various materials and shapes
- The perfect way to find your pick
- Available in medium and heavy (exact thickness varies depending on pick type)

Format	Retail	Item #	Description
7-pack	\$5.25	1XVP4-5	Medium Gauge
7-pack	\$5.25	1XVP6-5	Heavy Gauge



Duralin™ Picks

Standard and Wide Shapes

Duralin (also known as Acetal or Delrin®) is a unique material with an extraordinary combination of strength, stiffness, dimensional stability, abrasion resistance, and low friction. Duralin picks allow an artist to highlight the bright “clicking” sound of the pick hitting the strings when playing acoustic, rhythm guitar, and fast single-note passages.



			Super Light .020in (.50mm) Red	Light .024in (.60mm) Orange	Light/Medium .028in (.70mm) Yellow	Medium .033in (.85mm) Green	Medium/Heavy .039in (1.0mm) Blue	Heavy .047in (1.2mm) Purple	Extra Heavy .059in (1.5mm) Black
Format	Retail	Description	Item #	Item #	Item #	Item #	Item #	Item #	Item #
10-pack	\$5.25	Standard Shape	1DRD1-10	1DOR2-10	1DYL3-10	1DGN4-10	1DBU5-10	1DPR6-10	1DBK7-10
25-pack	\$11.60	Standard Shape	1DRD1-25	1DOR2-25	1DYL3-25	1DGN4-25	1DBU5-25	1DPR6-25	1DBK7-25
100-pack	\$40.75	Standard Shape	1DRD1-100	1DOR2-100	1DYL3-100	1DGN4-100	1DBU5-100	1DPR6-100	1DBK7-100
10-pack	\$6.40	Wide Shape	2DRD1-10	2DOR2-10	2DYL3-10	2DGN4-10	2DBU5-10	2DPL6-10	N/A
25-pack	\$14.00	Wide Shape	2DRD1-25	2DOR2-25	2DYL3-25	2DGN4-25	2DBU5-25	2DPL6-25	N/A
100-pack	\$46.55	Wide Shape	2DRD1-100	2DOR2-100	2DYL3-100	2DGN4-100	2DBU5-100	2DPL6-100	N/A

*Delrin® is a registered trademark of E.I. DuPont de Nemours & Co. (Inc.)



Duragrip™ Picks

Standard Shape

Utilizing all the same great characteristics of Duralin™ Picks, Duragrip Picks feature a unique, pressure-stamped checkerboard texture that offers superior grip while playing.

			Super Light .020in (.50mm) Red	Light .024in (.60mm) Orange	Light/Medium .028in (.70mm) Yellow	Medium .033in (.85mm) Green	Medium/Heavy .039in (1.0mm) Blue	Heavy .047in (1.2mm) Purple	Extra-Heavy .059in (1.5mm) Black
Format	Retail	Description	Item #	Item #	Item #	Item #	Item #	Item #	Item #
10-pack	\$11.05	Standard	7DRD1-10	7DOR2-10	7DYL3-10	7DGN4-10	7DBU5-10	7DPR6-10	7DBK7-10
25-pack	\$25.45	Standard	7DRD1-25	7DOR2-25	7DYL3-25	7DGN4-25	7DBU5-25	7DPR6-25	7DBK7-25
100-pack	\$99.60	Standard	7DRD1-100	7DOR2-100	7DYL3-100	7DGN4-100	7DBU5-100	7DPR6-100	7DBK7-100



Duralin™ Precision Picks

Standard Shape

Duralin Precision Picks add a sharp tip radius that glides across strings for greater articulation, speed, and control. It is the perfect pick for progressive rock, speed metal, jazz, or any style that requires increased control and dynamics while maintaining a bright sound and extreme durability which Duralin picks are known for.

			Super Light .020in (.50mm) Red	Light .024in (.60mm) Orange	Light/Medium .028in (.70mm) Yellow	Medium .033in (.85mm) Green	Medium/Heavy .039in (1.0mm) Blue	Heavy .047in (1.2mm) Purple	Extra-Heavy .059in (1.5mm) Black
Format	Retail	Description	Item #	Item #	Item #	Item #	Item #	Item #	Item #
10-pack	\$5.25	Standard	6DRD1-10	6DOR2-10	6DYL3-10	6DGN4-10	6DBU5-10	6DPR6-10	6DBK7-10
25-pack	\$11.60	Standard	6DRD1-25	6DOR2-25	6DYL3-25	6DGN4-25	6DBU5-25	6DPR6-25	6DBK7-25
100-pack	\$40.75	Standard	6DRD1-100	6DOR2-100	6DYL3-100	6DGN4-100	6DBU5-100	6DPR6-100	6DBK7-100

Black Ice™ Picks

Black Ice Picks feature a custom jazz shape that is perfect for fast picking and playing where precise articulation is required. Perfect for both rhythm and lead work, the Black Ice Picks are triple “tumbled,” delivering a soft-touch texture that provides an incredibly smooth surface and superb grip. Made from D’Addario Duralin™, this ultra-durable material delivers strength and resilience, and resists abrasion while providing a balanced tone with a bright attack. Black only.



		Light .021in (.55mm)	Medium .031in (.80mm)	Heavy .043in (1.10mm)	Extra-Heavy .059in (1.5mm)
Format	Retail	Item #	Item #	Item #	Item #
10-pack	\$6.40	3DBK2-10	3DBK4-10	3DBK6-10	3DBK7-10
25-pack	\$14.00	3DBK2-25	3DBK4-25	3DBK6-25	3DBK7-25
100-pack	\$49.40	3DBK2-100	3DBK4-100	3DBK6-100	3DBK7-100

THE CURE FOR PEDALBOARD OCD



D'ADDARIO DIY PEDALBOARD POWER CABLE KIT

Pedalboard perfectionists are a different breed of guitarist. They won't accept straight out of the box power solutions for their carefully curated effect chains. That's why the D'Addario Pedalboard Power Cable Kit is designed to organize and customize even the most eclectic collection of pedals to share the same board. This kit allows you to create six premium-quality power cables of any length, each capable of being configured straight on, or at a 90° angle. This gives you superior reliability, control, and the flexibility to create the perfect home for your audio arsenal.

[DADDARIO.COM/PEDALPOWERKIT](https://www.daddario.com/pedalpowerkit)

D'Addario



American Stage™ Cables

American Stage Instrument Cables all add up to tone: the best materials, a customized design, and USA precision manufacturing combine to deliver a truly unique, professional performance cable.

Our custom USA-made wire reproduces full lows and rich highs to accurately transfer your true tone with clarity and noise-free operation. Our in-line HeliOfused solder process utilizes modern micro-flame technology and specially formulated RoHS compliant solder to create a permanent bond between the wire and connector for unsurpassed strain relief and durability. And speaking of connectors, ours are exclusively designed to exacting specifications and built with confidence by Neutrik® in their state-of-the-art facility in Lichtenstein.

And finally, our patented GeoTip™ provides a seamless and secure connection between your guitar and amp. Built from the ground up, American Stage Instrument Cables ensure that nothing comes between you and your tone.

Patent #US 7967643

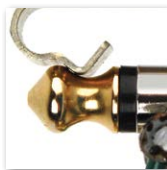

GEOTIP™ CONNECTION:

Patented GeoTip design ensures a secure connection in any instrument, pedal, or amp jack.



ORDINARY CONNECTION:

Mechanical tolerances on 1/4" jacks used in most guitars over the last sixty years vary. As a result, some plugs may not connect and lock in well. GeoTip is designed to accommodate these out-of-tolerance jacks.



American Stage™ Killswitch Cables

The American Stage Killswitch cables feature a momentary kill switch for silencing the cable during live instrument changes, avoiding loud pops and squeals that can damage amplifiers.

Instrument

Item #	Length	Retail
PW-AMSK-10	10ft.	\$73.05
PW-AMSK-15	15ft.	\$79.05

Instrument

Item #	Length	Retail
PW-AMSK-20	20ft.	\$86.05
PW-AMSK-30	30ft.	\$99.00



Straight to Straight

Item #	Length	Retail
PW-AMSG-10	10ft.	\$42.05
PW-AMSG-15	15ft.	\$52.65
PW-AMSG-20	20ft.	\$63.10
PW-AMSG-30	30ft.	\$73.60



Right Angle to Right Angle

Item #	Length	Retail
PW-AMSGRR-10	10ft.	\$52.65
PW-AMSGRR-15	15ft.	\$66.60
PW-AMSGRR-20	20ft.	\$73.60



Right Angle to Straight

Item #	Length	Retail
PW-AMSGRA-10	10ft.	\$47.40
PW-AMSGRA-15	15ft.	\$61.60
PW-AMSGRA-20	20ft.	\$63.10



Right Angle to Right Angle Patch

Item #	Length	Retail
PW-AMSPRR-105	6in	\$37.00



Microphone

Item #	Length	Retail
PW-AMSM-05	5ft.	\$56.85
PW-AMSM-10	10ft.	\$63.10
PW-AMSM-25	25ft.	\$94.65

CLASSIC SERIES CABLES



Classic Series Instrument Cables

D'Addario Classic Series Instrument Cables utilize ultra-pure, oxygen-free copper conductors for low capacitance and pure tone. A single-molded strain relief plug provides durability and worry-free reliability, and the 90% spiral shielding eliminates virtually all handling noise.

- Special coaxial cable design provides extra-clean signal and low capacitance
- Molded connectors provide extra protection over ordinary plugs
- Patch cables have low capacitance cable design with dense copper shield and are perfect for use with effects pedals



Single Conductor Instrument Cables

Item #	Length	Retail
PW-CGT-05	5ft.	\$15.55
PW-CGT-10	10ft.	\$18.30
PW-CGT-15	15ft.	\$21.05
PW-CGT-20	20ft.	\$22.90



Single Conductor Patch Cables

Item #	Length	Retail
PW-CGTP-01	1ft.	\$11.90
PW-CGTP-03	3ft.	\$13.80

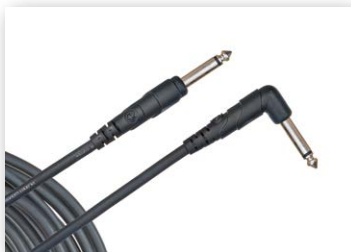

Right Angle Single Conductor Instrument Cables

Item #	Length	Retail
PW-CGTRA-10	10ft.	\$18.30
PW-CGTRA-20	20ft.	\$22.85



TOP★SELLER

Right Angle Single Conductor Patch Cables

Item #	Length	Retail
PW-CGTP-305	0.5 ft. (3-pack)	\$22.85
PW-CGTPRA-01	1ft.	\$11.90
PW-CGTPRA-03	3ft.	\$13.80



Right Angle Single Conductor Patch Cables Fish Bowl

- 25 individual Classic Series 6" right angle patch cables
- Save counter space with just a 7" footprint

Item #	Length	Retail
PW-CGTP-105	0.5ft	\$7.15*

*Must be ordered in increments of 25.
Retail value of \$178.75

Classic Series Microphone Cables

D'Addario Classic Series Microphone Cables feature ultra-pure, oxygen-free copper conductors with a dense spiral shield for improved signal clarity and maximum RFI and EMI rejection. The cable design allows your instrument's brilliance, presence, and character to be transmitted with the utmost transparency, while the plug's chuck style strain relief ensures the durability of the soldered connections.

- Oxygen-free copper conductor
- Dense spiral shielding
- Extra heavy, flexible outer jacket is durable and abrasion resistant



XLR Male to XLR Female

Item #	Length	Retail
PW-CMIC-10	10ft.	\$25.45
PW-CMIC-25	25ft.	\$32.00
PW-CMIC-50	50ft.	\$53.70

Classic Series Speaker Cables

D'Addario Classic Series Speaker Cables utilize ultra-fine, stranded, premium-quality 16 AWG copper conductors for maximum signal transfer and flexibility. A single-molded strain relief plug provides durability and worry-free reliability.

- Extra heavy, flexible outer jacket is durable and abrasion resistant
- Ultra-fine stranded premium-quality copper 16 AWG conductor offers maximum signal transfer and flexibility



1/4" Speaker Cables

Item #	Length	Retail
PW-CSPK-03	3ft.	\$14.10
PW-CSPK-05	5ft.	\$15.55
PW-CSPK-10	10ft.	\$20.05
PW-CSPK-25	25ft.	\$34.70
PW-CSPK-50	50ft.	\$63.15

Unbalanced Microphone Cable

- Nickel-plated brass connectors offer reliable, corrosion-resistant contact
- Flexible, molded collar for outstanding strain relief
- Heavy-duty, copper spiral shielding



XLR Female to 1/4"

Item #	Length	Retail
PW-CGMIC-25	25ft.	\$32.00



D'Addario strings & D'Addario cables are a must-have for every gig.

Lyle Workman

CUSTOM SERIES CABLES



Custom Series Instrument Cables

D'Addario Custom Series Instrument Cables utilize ultra-pure, oxygen-free copper conductors for low capacitance and pure tone. Encapsulated and impenetrable soldering points with double-molded strain relief provide maximum durability and worry-free reliability. Two layers of shielding provide 100% coverage for superior insulation and noise rejection, making this the ultimate high-performance cable.

- Gold-plated plugs ensure reliable, corrosion-resistant contact
- Exclusive D'Addario overmolded connectors provide extra protection with unmatched strain relief
- Special double-insulated, double-shielded cable design provides the cleanest signal available while eliminating hum and triboelectric noise

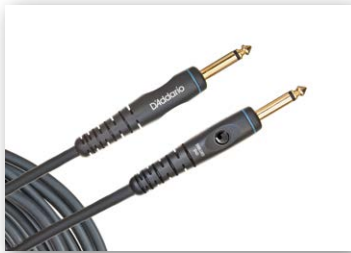

Mono Twisted Pair Instrument Cables

Item #	Length	Retail
PW-G-05	5ft.	\$26.90
PW-G-10	10ft.	\$32.25
PW-G-15	15ft.	\$37.60
PW-G-20	20ft.	\$42.95
PW-G-30	30ft.	\$53.70



Patch Cables

Item #	Length	Retail
PW-PC-01	1ft.	\$18.30
PW-PC-02	2ft.	\$20.40

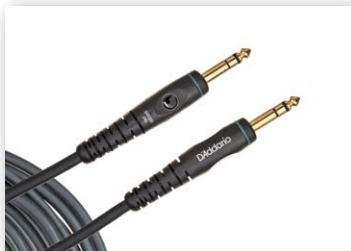

Stereo Twisted Pair Instrument Cables

Item #	Length	Retail
PW-GS-10	10ft.	\$37.60
PW-GS-25	25ft.	\$48.35

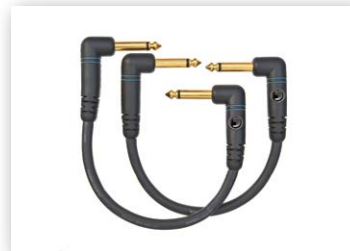

Right Angle Patch Instrument Cables

(Sold in pairs)

Item #	Length	Retail
PW-PRA-205	6in.	\$42.95

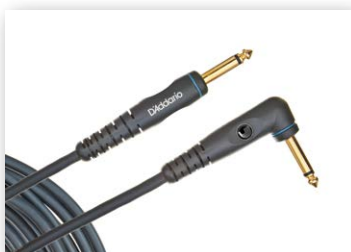

Right Angle Twisted Pair Instrument Cables

Item #	Length	Retail
PW-GRA-10	10ft.	\$32.25
PW-GRA-20	20ft.	\$42.95

Custom Series Speaker Cables

D'Addario Custom Series Speaker Cables utilize ultra-fine, stranded, premium-quality 14AWG copper conductors for maximum signal transfer and flexibility. Encapsulated and impenetrable soldering points with double-molded strain relief provide maximum durability and worry-free reliability. Our exclusive D'Addario overmolded connectors provide extra protection with unmatched strain relief.



1/4" Speaker Cables

Item #	Length	Retail
PW-S-03	3ft.	\$29.15
PW-S-05	5ft.	\$32.25
PW-S-10	10ft.	\$37.60
PW-S-25	25ft.	\$55.15



Twist Connector Speaker Cables

- Ultra-fine stranded premium-quality copper 14 AWG conductor offers maximum signal transfer and flexibility
- Twist connectors ensure positive connection into speaker terminals

Item #	Length	Retail
PW-SO-03	3ft.	\$44.70
PW-SO-05	5ft.	\$45.95
PW-SO-10	10ft.	\$48.35
PW-SO-25	25ft.	\$75.15



NEW! Twist to 1/4" Speaker Cable

The Twist to 1/4" Speaker Cable connects twist speaker jacks (also commonly known as SpeakOn) to speaker cabinets or amplifiers that only have 1/4" jacks.

Item #	Length	Retail
PW-SOS-05	5ft.	\$42.95

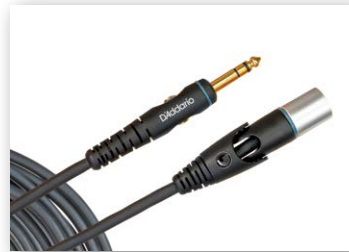

Custom Series Swivel XLR Male to Balanced 1/4" Connectors

- Perfect for connecting powered studio monitors
- 24-gauge OFC conductors with double-shielding provide clear, low-noise signal

Item #	Length	Retail
PW-GMMS-05	5ft.	\$35.50
PW-GMMS-10	10ft.	\$46.20



MIDI Cables

- Gold-plated plugs provide superior data transfer
- Double-shielded cable for 100% shield coverage and error-free data transmission
- Exclusive D'Addario overmolded connectors provide extra protection with unmatched strain relief

Item #	Length	Retail
PW-MD-05	5ft.	\$24.70
PW-MD-10	10ft.	\$28.00
PW-MD-20	20ft.	\$36.55



D'Addario cables are the veins in my rig, pumping consistent, quality tone.

**Anders Nyström,
Katatonia / Bloodbath**

CUSTOM SERIES CABLES

Custom Series Circuit Breaker™ Cables

The Circuit Breaker plug includes a momentary kill switch, allowing noise-free live instrument changes even at blaring concert volume. Simply activate the mute function while plugging and unplugging the cable to avoid unnecessary and possibly damaging pops and squeals. Circuit Breaker Cables utilize ultra-pure, oxygen-free copper conductors for low capacitance and pure tone. Solderless plugs ensure a solid connection, and are easy to fix on the gig. Two layers of shielding provide 100% coverage for superior insulation and noise rejection, making this the ultimate high-performance cable.

Available in momentary (press and hold for mute) and the new latching (on-off-on) models.

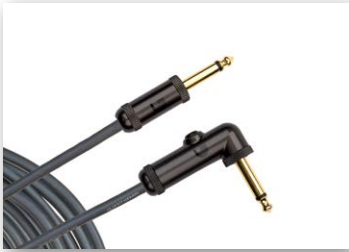

Momentary Straight

Item #	Length	Retail
PW-AG-10	10ft.	\$44.20
PW-AG-15	15ft.	\$49.85
PW-AG-20	20ft.	\$55.35
PW-AG-30	30ft.	\$66.40

Momentary Right Angle

Item #	Length	Retail
PW-AGRA-10	10ft.	\$44.20
PW-AGRA-20	20ft.	\$55.35

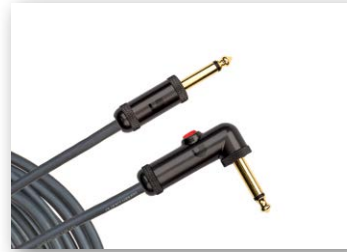

Latching Straight

Item #	Length	Retail
PW-AGL-10	10ft.	\$44.20
PW-AGL-15	15ft.	\$49.85
PW-AGL-20	20ft.	\$55.35
PW-AGL-30	30ft.	\$66.30

Latching Right Angle

Item #	Length	Retail
PW-AGLRA-10	10ft.	\$44.20
PW-AGLRA-20	20ft.	\$55.35

Swivel XLR Cables

- Patented swivel XLR plug easily fits in tight coffin cases and racks
- Double-insulated, double-shielded cable provides ultra-clean signal
- Exclusive D'Addario overmolded connectors provide extra protection with unmatched strain relief
US Patent# D 491,526



180° rotation



Swivel XLR Female to Swivel XLR Male

Item #	Length	Retail
PW-MS-10	10ft.	\$48.35
PW-MS-25	25ft.	\$64.35

Custom Series Microphone Cables

Custom Series Cables utilize ultra-pure, oxygen-free copper conductors for low capacitance and pure tone. Encapsulated and impenetrable soldering points with double-molded strain relief provide maximum durability and worry-free reliability. Two layers of shielding provide 100% coverage for superior insulation and noise rejection, making this the ultimate, high-performance cable.

- 24k gold-plated plugs ensure premium sound quality and corrosion resistance
- Special double-insulated, double-shielded cable provides cleanest signal available while eliminating hum and triboelectric noise
- Exclusive D'Addario overmolded connectors provide extra protection with unmatched strain relief



XLR Male to XLR Female

Item #	Length	Retail
PW-M-05	5ft.	\$34.65
PW-M-10	10ft.	\$42.95
PW-M-25	25ft.	\$59.05

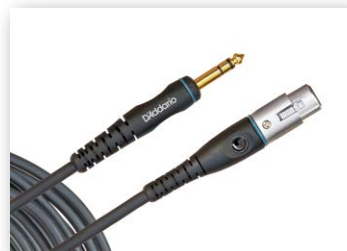

XLR Female to 1/4" Connectors

Item #	Length	Retail
PW-GM-10	10ft.	\$37.60
PW-GM-25	25ft.	\$59.05

SOLDERLESS CABLE SYSTEMS



DIY Solderless Cables

D'Addario Solderless Cable Kits are the ultimate solution for custom wiring pedalboards, rack gear, and your entire layout from guitar to amp. Say goodbye to messy, unreliable wiring, and custom-cut cable lengths to best suit your needs. D'Addario plugs and cables are specially designed to provide the most accurate and reliable sound reproduction, from guitar to amp and all points in-between.

Cable Station™ Plugs, Cutters & Cables

Item #	Description	Retail
PW-GRAP-2	Right Angle 1/4" Un-switched Patch Plug - 2-pack	\$29.60
PW-GP-2	Straight 1/4" Un-switched Patch Plug - 2-pack	\$25.55
PW-AGRAP-1	Right Angle 1/4" Circuit Breaker Plug	\$15.60
NEW! PW-AGRAP-2	DIY 1/4" Rt Angle Plug w/ latching circuit breaker switch	\$19.05
PW-AGP-1	Straight 1/4" Circuit Breaker Plug	\$15.60
NEW! PW-AGP-2	DIY Straight plug w/ latching circuit breaker switch	\$19.05

Cable Station™ Plugs, Cutters & Cables

Item #	Description	Retail
PW-GP-1	Straight 1/4" Un-switched Plug - Large	\$11.85
PW-CCM	Mini Cable Cutter	\$7.20
PW-CCT	Cable Cutter & Tester	\$40.90
PW-INSTC-25	Bulk 25' coil of instrument cable w/ mini cable cutter	\$41.05



Cable Ties

The D'Addario Cable Ties are the perfect way to keep cables neat and organized—simply clip onto all cables with a 1/4" diameter and use resilient elastic to secure the cable. Sold in 10-packs or choose 25 3-packs in a convenient POP counter top fish bowl, containing 25- and 3-packs

Item #	Description	Retail
PW-ECT-10	10-pack	\$14.20
PW-ECT-03	3-Pack	\$4.95



Gaffers Tape

- US Made
- Premium Quality
- Residue free
- Non Reflective

Item #	Description	Retail
PW-GTP-25	2 in x 25 yds - black	\$31.45
NEW! PW-GTP-25W	2 in x 25 yds - white	\$31.45

SOLDERLESS CABLE SYSTEMS



**NO SOLDERING.
NO HASSLES.
NO EXCUSES.**



NEW! DIY Solderless Pedalboard Power Cable Kit

The D'Addario DIY Solderless Pedalboard Power Cable Kit is the ultimate solution for custom wiring the DC cables of your pedalboard. Common power supplies come with pre-made cables that lead to excess wire and clutter on your pedalboard. The D'Addario cable kits are as simple as cutting the included cable to length, placing the cable into the plug end, and securing the set screw to produce flawless, perfect length cables. This proprietary cable has 3 times the amount of copper over standard cables for superior voltage transfer and reliability, and the plugs configure for straight or right-angle connections. The DIY Pedalboard Power Cable Kit comes complete with a cable tester to easily check the cables for proper connection before installation. Make your pedalboard the neatest it can be with D'Addario DIY Cable Kits.

Item #	Retail
PW-PWRKIT-20	\$145.00



TOP★SELLER

DIY Solderless Pedalboard Cable Kit

- Includes 10ft. of cable and 10 right-angled 1/4" plugs
- Solderless plugs connect to cable in seconds, creating exact, required lengths easily!
- 24k gold-plated plugs for improved signal flow and corrosion resistance
- Cable features a 24-gauge OFC conductor in a low capacitance design with two layers of impenetrable shielding
- Includes mini cable cutter and screwdriver

Item #	Retail
PW-GPKIT-10	\$127.65



DIY Solderless Instrument Cable Kit

- Based on our best-selling Pedalboard Cable Kit
- Allows custom cable lengths from instrument to pedals to amplifier
- Includes 40ft. of cable, 6 right-angled 1/4" plugs, and 4 straight 1/4" plugs
- 24k gold-plated plugs and a solderless connection design for easy construction
- Cable features a 24-gauge OFC conductor in a low capacitance design with two layers of impenetrable shielding
- Includes mini cable cutter and screwdriver

Item #	Retail
PW-GPKIT-50	\$163.45

NEW! IEC Power Line

Newly added to the cable offering, the D'Addario Premium Power Cables are designed to take the toughest treatment and performance schedules possible. These cables feature more copper than standard 18AWG cables supplied with most amplifiers. The larger conductor size prohibits any possible current degradation of inferior cables, while the 10ft length allows you to reach most outlets without the need for extension cords or power strips.

In addition to the standard power cable, we also have the Power Cable+ which has an **integrated accessory outlet**. Now you have an extra outlet on the stage which is perfect for mobile devices, pedal boards, and other electronics used in gigging situations.

Lastly, we have the IEC to standard plug adaptor. Did you ever get to your rehearsal or show only to realize you left your power cable at home? Every musician has been there. The D'Addario IEC adaptor saves the day by allowing you to convert any standard extension cord into an IEC power cable. With its compact size, it's an essential gig bag item!

The adaptor and cables are available in NEMA, F, and G plug styles (NEMA shown below).

Item #	Description	Retail
A	PW-IECG-10 IEC TO G Plug Power Cable 10FT (UK)	\$47.20
B	PW-IECF-10 IEC TO F Plug Power Cable 10FT (Euro)	\$39.10
C	PW-IECB-10 IEC TO NEMA Power Cable 10FT (North America)	\$46.75
D	PW-IECPG-10 IEC TO G Power Cable Plus 10FT (UK)	\$59.15
E	PW-IECPF-10 IEC TO F Power Cable Plus (Euro)	\$47.70
F	PW-IECPB-10 IEC TO NEMA Power Cable Plus (North America)	\$57.25
G	PW-IECGA-01 IEC-G Plug Adaptor (UK)	\$17.15
H	PW-IECFA-01 IEC-F Plug Adaptor (Euro)	\$14.30
I	PW-IECBA-01 IEC-NEMA Adaptor (North America)	\$11.40



A



B



C



**INTEGRATED
ACCESSORY
OUTLET**

D



**INTEGRATED
ACCESSORY
OUTLET**

E



**INTEGRATED
ACCESSORY
OUTLET**

F



G



H



I

MODULAR SNAKE SYSTEM



Modular Snake System

The D'Addario Modular Snake System makes it easy to customize a cable configuration to your specific needs. The snakes feature interchangeable breakouts for easy and flexible wiring options, utilizing industry standard analog pinouts. It's as easy as choosing the core cable length and the proper breakouts for the situation. D'Addario snakes are made with our proprietary multi-pair snake cable, featuring oxygen-free copper conductors and 100% shielding in a low-noise, low-signal loss construction. Additionally, the snakes feature Amphenol gold-plated connectors for optimal signal transference, corrosion resistance and strain relief.



Core Cables

Item #	Length	Retail
PW-DB25MM-05	5ft.	\$38.95
PW-DB25MM-10	10ft.	\$51.90
PW-DB25MM-25	25ft.	\$77.95
PW-DB25MM-50	50ft.	\$155.75
PW-DB25FC-01	DB25 Female Coupler	\$22.10

Breakout Cables

Item #	Description	Retail
PW-TRSB-01	TRS Breakout	\$77.90
PW-XLRMB-01	XLR Male Breakout	\$129.80
PW-XLRFB-01	XLR Female Breakout	\$129.80
PW-XLRMFB-01	4 XLR Male/4 XLR Female Breakout	\$129.80
PW-CFB-01	Connector-Free Breakout	\$22.10

AUDIO CABLES



NEW! Custom Series 1/8" to Dual 1/4" and XLR Audio Cables

The D'Addario Custom Series line of audio cables now features a way to connect your mobile device to your sound system in stereo with ease. Available in two varieties, simply plug the 1/8" plug into the headphone jack of your mobile device and insert the two plugs (L/R XLR or 1/4" plugs) into the desired channel in your sound system.

- Connects your mobile device to your sound system
- 2-channel stereo output
- Available in dual 1/4" and XLR plugs

Item #	Description	Retail
PW-MPXLR-06	1/8" Straight to dual XLR male - 6ft	\$28.55
PW-MPTS-06	1/8" Straight to dual 1/4" straight - 6ft	\$32.45

Coupler Adaptors

Item #	Connector	Retail
A	PW-P047A 1/4" Male Mono (Inline)	\$11.35
B	PW-P047B 1/4" Male Mono (Offset)	\$13.65
C	PW-P047CC XLR Female	\$12.10
D	PW-P047EE XLR Male	\$9.90
E	PW-P047T 1/4" Female Stereo	\$9.90

Dual Adaptors

Item #	Connector	Retail
F	PW-P047C 1/8" Male Stereo to Dual RCA Female	\$12.50
G	PW-P047ZZ 1/8" Male Stereo to Dual 1/8" Female Stereo	\$17.55

Single Adaptors

Item #	Connector	Retail
H	PW-P047E 1/4" Male Stereo to 1/8" Female Stereo	\$12.10
I	PW-P047Z XLR Male to 1/4" Female Balanced	\$9.90
J	PW-P047BB XLR Female to 1/4" Female Balanced	\$12.10
K	PW-P047AA 1/4" Male Balanced to XLR Female	\$13.20
L	PW-P035N SpeakOn® Female to 1/4" Female Mono	\$31.05

Headphone Extension Cables

Item #	Length	Retail
PW-EXT-HD-10	10 ft.	\$26.90
PW-EXT-HD-20	20 ft.	\$34.40

Dual RCA to Stereo Mini Cable

Item #	Length	Retail
PW-MP-05	5ft.	\$21.90

1/8" to 1/8" Stereo Cable

Item #	Length	Retail
PW-MC-03	3ft.	\$17.40

**GREAT
FOR MP3
PLAYERS**

D'Addario cables and adaptors may be protected by one or more of the following U.S. patents: D491,526 6,494,746 · 6,533,617 · 6,561,846 · 6,568,964 · 6,729,912 · D496,909 · D510,071 and foreign rights.

Capo Display

This attractive display allows customers to demo a variety of capos on a simulated guitar neck labeled with model names and descriptions. From screw trigger style, D'Addario features a full line of capos that are sure to fit the preference of every guitarist.

Capo Display is FREE with a buy-in of 5 of each featured capo:

- NS Capo Pro (PW-CP-02) (see page 36)
- NS Capo Lite (PW-CP-07) (see page 37)
- NS Artist Capo (PW-CP-10) (see page 34)
- NS Tri-Action Capo (PW-CP-09) (see page 38)

Capos are secured with a discreet black cord to deter theft. 7.5" base diameter, 14" in height.

Item #	Description
PW-CAPODIS	Capo Display
PW-CAPODISB	Capo Display Bracket



D'Addario Brochure Rack

This wire frame holder attaches neatly onto any slatwall, EVUMS or JRUMS fixture and will fit any of our branded gear or survival guide brochures.

Item # DD-WLH



Countertop Pick Display

D'Addario stocks a full line of the most popular guitar pick materials, all USA-made and now showcased in an attractive countertop display. This one-stop-shop makes it convenient for customers to reach peak pick performance within moments.

- Comfortably holds up to 50 bulk picks
- Up to 30 different SKU types in a sleek, attractive counter display

Item #	Description	Retail
PW-WDPICKDIS	Empty Counter Unit	
PW-WDPICKDIS-25	Counter Unit w/ Assortment	\$1191.35



NEW! Guitar Strap Slat Wall Display

D'Addario's Guitar Strap Slat Wall Display features a swinging hook design that keeps all straps front-facing on the display. Now customers can casually browse the D'Addario strap assortment without worrying about digging through a rack and dropping straps all over the floor. Each display holds 48 straps (24 SKUs and 2/hook). Contact your sales rep for full assortment buy-ins.

Item #
PW-STRAPDIS-01

A note from Sales

Please contact your D'Addario sales representative for information on pre-selected strap styles and assortments. Call 1-800-268-6855 or email orders@daddariocanada.com



Strap Tree Display

This Strap Tree Display provides a 360° efficient footprint with a classy look. Two levels of hooks neatly display folded straps while each side panel includes two hooks for leather.

Item #	Description
STD	Strap Tree
LSDA	Sign

Suggested Product Mix

Item #	Description	Qty
T20W1404	Red Buffalo Check	3
T20W1407	Silver Polka Dots	4
T20W1410	Blue and Red Tie	4
T20W1422	Monterey, Green	3
P20W1405	Camouflage	4
P20W1406	Optical Art	3
P20W1411	Green Sugar Skulls	3
P20W1412	Black Sugar Skulls	4
P20W1419	Blue Paisley	3
P20W1421	Black & Red Large Checkerboard	3
T20W1503	Black & White Tartan	3
20T04	Gothica	3
20T05	Gold Star	3
P20S1508	White Optical Stripes	3
50F05-RL	Pad Lock Guitar Strap	4
50PAC08	Monterey, Acoustic Quick Release	3
50PLA04	Barbed Wire, Planet Lock	3
PWSPL200	Poly-pro Black, Planet Lock	4
50PLA05-PD	Black Nylon, Planet Lock w/ Shoulder Pad	4
L25W1403	Embossed Flowers - Black	1
L25W1404	Embossed Weave - Brown	1
25L00-DX	Classic Leather - Black	1
L25S1501	Braided Leather	1
L25W1502	Perforated Flowers - White	1
L25S1503	Hex Studs	1
L25S1504	Laced - Black	1
L25S1505	Laced - White	1
L25W1500	Tribal Tattoo	1
L25S1502	Strings & Studs	1
L25S1500	Snake Window	1
L25W1501	Decorative Stitch	1
20SD04	Suede with Cork Design	1
L25S1500	Snake Window	1
L25W1501	Decorative Stitch	1
20SD04	Cork - Suede	1
20SD00	Silver Snakeskin - Suede	1
25L01-DX	Classic Leather - Brown	1
25VNS00-DX	Stonewashed Contrast Stitch - Black	1

DISPLAYS

Floor Displays

The Junior UMS is a compact display solution ideal for any size retail store. Each of the existing D'Addario display components may be applied to this UMS, including drumhead baskets, cable shelving, strap fixtures and slatwall hooks. Suggested assortments are available and may be customized to meet the particular needs of the retailer. Includes hooks.

The Cable Floor Display is the perfect way to show off the vast lineup of D'Addario cables. The slim, free-standing floor display is two-sided, holding 8 total SKU's with hooks comfortably holding 5-6 units.

A note from Sales

Please contact your D'Addario sales representative for information on pre-selected cable buy-in options. 1-800-268-6855 or email orders@daddariocanada.com



JRUMS Suggested Product Mix

Panel A: Premium Cables

Item #	Description	Qty
Row 1		
PW-AMSG-10	10' American Stage Instrument	5
PW-AMSG-20	20' American Stage Instrument	5
Row 2		
PW-AMSGRA-10	10' American Stage Instrument (R-S)	5
PW-AMSGRA-20	20' American Stage Instrument (R-S)	5
Row 3		
PW-AMSK-15	15' American Stage Killswitch Cable	5
PW-GPKIT-10	DIY Solderless Pedalboard Cable Kit	5
Row 4		
PW-AMSM-10	10' American Stage Microphone	5
PW-AMSM-25	25' American Stage Microphone	5

Suggested Product Mix

Panel B: Classic Series & Non-Instrument Cables

Item #	Description	Qty
Row 1		
PW-G-10	10' Custom Series Instrument	5
PW-G-20	20' Custom Series Instrument	5
Row 2		
PW-AGL-10	10' Circuit Breaker Latching Instrument	5
PW-S-05	5' Custom Series Speaker	5
Row 3		
PW-CGT-10	10' Classic Series Instrument	5
PW-CGT-20	20' Classic Series Instrument	5
Row 4		
PW-CGTRA-10	10' Classic Series Instrument (R-S)	5
PW-CSPK-03	3' Classic Series Speaker Cable	5

Suggested Product Mix

Panel A: Tuners & Accessories

Item #	Description	Qty
Row 1		
PW-CT-12	NS Micro Tuner	5
PW-CT-15	NS Micro Soundhole Tuner	5
PWTF-A	Tuning Fork - A	5
Row 2		
PW-CT-15	NS Micro Soundhole Tuner	5
PW-CT-17BK	Eclipse Tuner - Black	5
DGS15	Acoustic Quick Release	5
Row 3		
PW-SH-01	Screeching Halt	5
PW-GD-01	Guitar Dock	5
PWPEP1	Pacato Hearing Protection	5
Row 4		
PW-OPBKL	O-Port Black - Large	5
PW-MPH-01	Mic Stand Pick Holder	5

Suggested Product Mix

Panel B: Capos & Care

Item #	Description	Qty
Row 1		
PW-CP-10	NS Artist Capo	5
PW-CP-09	Tri-Action Capo - Black	5
PW-CP-13	NS Artist Classical Capo	5
Row 2		
PW-CP-02	NS Capo Pro - Black	5
PW-CP-04	NS Classical Capo Pro	5
PW-CP-07	NS Lite Capo	5
Row 3		
DP0002	Pro-Winder Guitar	5
DP0002B	Pro-Winder Bass	5
PW-HDS	Headstand	5
Row 4		
GH	Acoustic Guitar Humidifier	5
UHP	Ukulele Humidifier Pro	5
PW-VG-01	Varigrip	5

D'ADDARIO

PERCUSSION



PROMARK
BY D'ADDARIO

PROMARK
BY D'ADDARIO

MEDIUM WEIGHT
5A/5B/5C/5D/5E/5F/5G/5H/5I/5J/5K/5L/5M/5N/5O/5P/5Q/5R/5S/5T/5U/5V/5W/5X/5Y/5Z/5AA/5AB/5AC/5AD/5AE/5AF/5AG/5AH/5AI/5AJ/5AK/5AL/5AM/5AN/5AO/5AP/5AQ/5AR/5AS/5AT/5AU/5AV/5AW/5AX/5AY/5AZ/5BA/5BB/5BC/5BD/5BE/5BF/5BG/5BH/5BI/5BJ/5BK/5BL/5BM/5BN/5BO/5BP/5BQ/5BR/5BS/5BT/5BU/5BV/5BW/5BX/5BY/5BZ/5CA/5CB/5CC/5CD/5CE/5CF/5CG/5CH/5CI/5CJ/5CK/5CL/5CM/5CN/5CO/5CP/5CQ/5CR/5CS/5CT/5CU/5CV/5CW/5CX/5CY/5CZ/5DA/5DB/5DC/5DD/5DE/5DF/5DG/5DH/5DI/5DJ/5DK/5DL/5DM/5DN/5DO/5DP/5DQ/5DR/5DS/5DT/5DU/5DV/5DW/5DX/5DY/5DZ/5EA/5EB/5EC/5ED/5EE/5EF/5EG/5EH/5EI/5EJ/5EK/5EL/5EM/5EN/5EO/5EP/5EQ/5ER/5ES/5ET/5EU/5EV/5EW/5EX/5EY/5EZ/5FA/5FB/5FC/5FD/5FE/5FF/5FG/5FH/5FI/5FJ/5FK/5FL/5FM/5FN/5FO/5FP/5FQ/5FR/5FS/5FT/5FU/5FV/5FW/5FX/5FY/5FZ/5GA/5GB/5GC/5GD/5GE/5GF/5GG/5GH/5GI/5GJ/5GK/5GL/5GM/5GN/5GO/5GP/5GQ/5GR/5GS/5GT/5GU/5GV/5GW/5GX/5GY/5GZ/5HA/5HB/5HC/5HD/5HE/5HF/5HG/5HH/5HI/5HJ/5HK/5HL/5HM/5HN/5HO/5HP/5HQ/5HR/5HS/5HT/5HU/5HV/5HW/5HX/5HY/5HZ/5IA/5IB/5IC/5ID/5IE/5IF/5IG/5IH/5II/5IJ/5IK/5IL/5IM/5IN/5IO/5IP/5IQ/5IR/5IS/5IT/5IU/5IV/5IW/5IX/5IY/5IZ/5JA/5JB/5JC/5JD/5JE/5JF/5JG/5JH/5JI/5JJ/5JK/5JL/5JM/5JN/5JO/5JP/5JQ/5JR/5JS/5JT/5JU/5JV/5JW/5JX/5JY/5JZ/5KA/5KB/5KC/5KD/5KE/5KF/5KG/5KH/5KI/5KJ/5KK/5KL/5KM/5KN/5KO/5KP/5KQ/5KR/5KS/5KT/5KU/5KV/5KW/5KX/5KY/5KZ/5LA/5LB/5LC/5LD/5LE/5LF/5LG/5LH/5LI/5LJ/5LK/5LL/5LM/5LN/5LO/5LP/5LQ/5LR/5LS/5LT/5LU/5LV/5LW/5LX/5LY/5LZ/5MA/5MB/5MC/5MD/5ME/5MF/5MG/5MH/5MI/5MJ/5MK/5ML/5MM/5MN/5MO/5MP/5MQ/5MR/5MS/5MT/5MU/5MV/5MW/5MX/5MY/5MZ/5NA/5NB/5NC/5ND/5NE/5NF/5NG/5NH/5NI/5NJ/5NK/5NL/5NM/5NN/5NO/5NP/5NQ/5NR/5NS/5NT/5NU/5NV/5NW/5NX/5NY/5NZ/5OA/5OB/5OC/5OD/5OE/5OF/5OG/5OH/5OI/5OJ/5OK/5OL/5OM/5ON/5OO/5OP/5OQ/5OR/5OS/5OT/5OU/5OV/5OW/5OX/5OY/5OZ/5PA/5PB/5PC/5PD/5PE/5PF/5PG/5PH/5PI/5PJ/5PK/5PL/5PM/5PN/5PO/5PP/5PQ/5PR/5PS/5PT/5PU/5PV/5PW/5PX/5PY/5PZ/5QA/5QB/5QC/5QD/5QE/5QF/5QG/5QH/5QI/5QJ/5QK/5QL/5QM/5QN/5QO/5QP/5QQ/5QR/5QS/5QT/5QU/5QV/5QW/5QX/5QY/5QZ/5RA/5RB/5RC/5RD/5RE/5RF/5RG/5RH/5RI/5RJ/5RK/5RL/5RM/5RN/5RO/5RP/5RQ/5RR/5RS/5RT/5RU/5RV/5RW/5RX/5RY/5RZ/5SA/5SB/5SC/5SD/5SE/5SF/5SG/5SH/5SI/5SJ/5SK/5SL/5SM/5SN/5SO/5SP/5SQ/5SR/5SS/5ST/5SU/5SV/5SW/5SX/5SY/5SZ/5TA/5TB/5TC/5TD/5TE/5TF/5TG/5TH/5TI/5TJ/5TK/5TL/5TM/5TN/5TO/5TP/5TQ/5TR/5TS/5TT/5TU/5TV/5TW/5TX/5TY/5TZ/5UA/5UB/5UC/5UD/5UE/5UF/5UG/5UH/5UI/5UJ/5UK/5UL/5UM/5UN/5UO/5UP/5UQ/5UR/5US/5UT/5UU/5UV/5UW/5UX/5UY/5UZ/5VA/5VB/5VC/5VD/5VE/5VF/5VG/5VH/5VI/5VJ/5VK/5VL/5VM/5VN/5VO/5VP/5VQ/5VR/5VS/5VT/5VU/5VV/5VW/5VX/5VY/5VZ/5WA/5WB/5WC/5WD/5WE/5WF/5WG/5WH/5WI/5WJ/5WK/5WL/5WM/5WN/5WO/5WP/5WQ/5WR/5WS/5WT/5WU/5WV/5WW/5WX/5WY/5WZ/5XA/5XB/5XC/5XD/5XE/5XF/5XG/5XH/5XI/5XJ/5XK/5XL/5XM/5XN/5XO/5XP/5XQ/5XR/5XS/5XT/5XU/5XV/5XW/5XX/5XY/5XZ/5YA/5YB/5YC/5YD/5YE/5YF/5YG/5YH/5YI/5YJ/5YK/5YL/5YM/5YN/5YO/5YP/5YQ/5YR/5YS/5YT/5YU/5YV/5YW/5YX/5YY/5YZ/5ZA/5ZB/5ZC/5ZD/5ZE/5ZF/5ZG/5ZH/5ZI/5ZJ/5ZK/5ZL/5ZM/5ZN/5ZO/5ZP/5ZQ/5ZR/5ZS/5ZT/5ZU/5ZV/5ZW/5ZX/5ZY/5ZZ

HEAVYWEIGHT
EVANS
LEVEL 360
A D'ADDARIO INNOVATION
USA

RAISING THE BAR

Evans by D'Addario is in constant search of new materials and technologies to create new products that solve problems and offer newfound benefits for drummers.

Earlier in 2017, Evans launched two marching heads to cater to the pipe band community as well as the drum corps circuit. The **Evans Pipe Band Snare Batter Head** combined durability with extreme sensitivity for both indoor and outdoor playing settings, solving two common issues in the field. Our **System Blue Marching Snare Heads** gave snare lines access to the best of both tone and feel, and they were on the field when Scott Johnson and the Blue Devils took first place at the 2017 DCI World Championships.

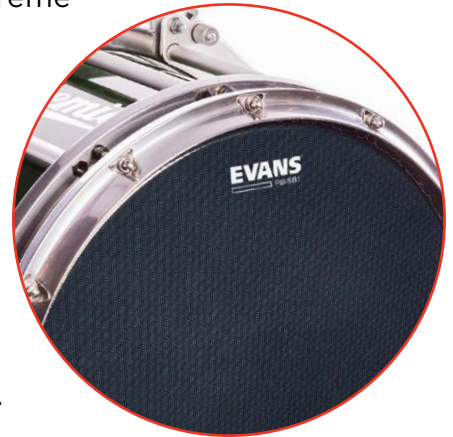

With the launch of **Evans UV1 Series**, we've seen a change in the mindset and buying habits of drummers, and it comes as no surprise. The combination of a unique, 10mil film with our patented new super coating and built-in Level 360 technology have brought an entirely new set of standards and expectations for a drumhead's sound, response, and durability. And under the hands of drummers like Omar Hakim, Larnell Lewis, and Ari Hoenig, there's no debate that UV1s are designed for the widest range of sonic possibilities.

But D'Addario Percussion has a constant drive and hunger to push the limits, so we're raising the bar yet again. By popular demand, Evans recently added a **UV1 Line Extension** to include an 8" tom head and tom packs in fusion, rock and standard configurations.



And to kick off the new year, we created the **UV1 Bass Head** for kick drums ranging from 16-26", with offerings in a standard UV1 along with two favorites in UV EQ4 and UV EMAD. Featuring the same warm, rich tones and durability benefits of UV1 tom and snare heads, the UV EQ4 has a fixed internal overtone control ring that reduces sustain and focuses the tonal response of the drum, while the UV EMAD offers the benefit of adjustable damping for added attack and focus.

Stay tuned for these and more exciting innovations from D'Addario Percussion to help inspire your playing and give you the most versatile and durable products that drummers have ever laid their hands on.

TOP SELLERS & MUST HAVES



UV1 DRUMHEADS

(see page 106 + 114)



CALFTONE TOM & SNARE SINGLE-PLY HEADS

(see page 106)



G1 TOM & SNARE SINGLE-PLY HEADS

(see page 106)



G2 TOM & SNARE TWO-PLY HEADS

(see page 107)



HD DRY SNARE HEADS

(see page 111)



RESO 7 TOM RESONANT HEADS

(see page 109)



HYDRAULIC RED TOM & SNARE TWO-PLY HEADS

(see page 108)



SNARE SIDE 300 HEADS

(see page 112)



HEAVYWEIGHT SNARE & BASS HEADS

(see page 111 + 113)



EMAD2 BASS BATTER HEADS

(see page 113)

TOM & SNARE SINGLE-PLY HEADS



NEW! UV1

The UV1 series is designed for the widest range of sonic possibilities while remaining the most durable single-ply drumhead available. The patented UV-cured coating provides unmatched durability and consistency of texture, while the unique 10mil film delivers exceptional strength and versatility for a full range of musical applications. These drumheads are the number one solution for drummers who are tired of flaked, chipped, and worn out coatings. They also feature increased surface texture, making them extremely responsive for brush playing. Combined with Level 360 Technology™, the UV1 series is the most versatile and durable 10mil drumhead drummers have ever laid their hands on.

Coated (single-ply, 10mil)

Item #	Diameter	Retail
B08UV1	8"	\$29.10
B10UV1	10"	\$30.00
B12UV1	12"	\$31.30
B13UV1	13"	\$33.30
B14UV1	14"	\$35.30
B15UV1	15"	\$38.65
B16UV1	16"	\$39.75
B18UV1	18"	\$52.00



NEW! Calf-tone

Calf-tone drumheads are a synthetic alternative to traditional calfskin. These heads embody the calfskin look and sound but with the consistency, fit, and tuning range made standard with Level 360 Technology™. Made with a 7mil film base and blended with unique materials, these heads are thinner than our bass heads to help optimize the sound for smaller drums, higher tunings, and greater tonal response. They bring out the best of a vintage kit and evoke a classic appearance and sound from modern drums.

(single-ply, 7.5mil+7mil)

Item #	Diameter	Retail
TT08C7	8"	\$30.00
TT10C7	10"	\$31.50
TT12C7	12"	\$33.00
TT13C7	13"	\$35.25
TT14C7	14"	\$37.25
TT15C7	15"	\$39.75
TT16C7	16"	\$42.50
TT18C7	18"	\$51.75



TOP★SELLER

G1™

The single-ply industry standard G1s blend warmth, sustain, and articulation. The high-performance 10mil film ensures that the G1s are both durable and expressive. Excellent option for tom resonant heads.

Clear (single-ply, 10mil)

Item #	Diameter	Retail
TT06G1	6"	\$26.25
TT08G1	8"	\$27.25
TT10G1	10"	\$28.25
TT12G1	12"	\$29.25
TT13G1	13"	\$31.50
TT14G1	14"	\$33.00
TT15G1	15"	\$36.50
TT16G1	16"	\$37.50
TT18G1	18"	\$48.75
TT20G1	20"	\$54.75

Coated (single-ply, 10mil)

Item #	Diameter	Retail
B06G1	6"	\$26.25
B08G1	8"	\$27.25
B10G1	10"	\$28.25
B12G1	12"	\$29.25
B13G1	13"	\$31.50
B14G1	14"	\$33.00
B15G1	15"	\$36.50
B16G1	16"	\$37.50
B18G1	18"	\$48.75
B20G1	20"	\$54.75



G12™

Using an exclusive 12mil film, the G12 delivers the open and warm tone of a single-ply while the added thickness provides increased durability, attack, and projection for heavy hitters. On snare, the head produces a definitive "crack" while maintaining an ambient sound. The coating adds additional warmth, focus, and depth. Excellent option for tom resonant heads.

Clear (single-ply, 12mil)

Item #	Diameter	Retail
TT06G12	6"	\$26.25
TT08G12	8"	\$27.25
TT10G12	10"	\$28.25
TT12G12	12"	\$29.25
TT13G12	13"	\$31.50
TT14G12	14"	\$33.00
TT15G12	15"	\$36.50
TT16G12	16"	\$37.50
TT18G12	18"	\$48.75
TT20G12	20"	\$54.75

Coated (single-ply, 12mil)

Item #	Diameter	Retail
B06G12	6"	\$26.25
B08G12	8"	\$27.25
B10G12	10"	\$28.25
B12G12	12"	\$29.25
B13G12	13"	\$31.50
B14G12	14"	\$33.00
B15G12	15"	\$36.50
B16G12	16"	\$37.50
B18G12	18"	\$48.75
B20G12	20"	\$54.75



G14™

Evans G14 batter heads are the loudest, most durable single-ply drum heads on the market. Crafted using premium-quality film that is 14mil thick instead of the industry standard 10mil, the G14 delivers unprecedented durability without losing the strong, dynamic response of a single-ply drumhead. Ideal for use in high-volume performance situations, the G14 can withstand heavy playing while projecting through the mix to provide a full, aggressive sound.

Clear (single-ply, 14mil)

Item #	Diameter	Retail
TT06G14	6"	\$26.25
TT08G14	8"	\$27.25
TT10G14	10"	\$28.25
TT12G14	12"	\$29.25
TT13G14	13"	\$31.50
TT14G14	14"	\$33.00
TT15G14	15"	\$36.50
TT16G14	16"	\$37.50
TT18G14	18"	\$48.75
TT20G14	20"	\$54.75

Coated (single-ply, 14mil)

Item #	Diameter	Retail
B06G14	6"	\$26.25
B08G14	8"	\$27.25
B10G14	10"	\$28.25
B12G14	12"	\$29.25
B13G14	13"	\$31.50
B14G14	14"	\$33.00
B15G14	15"	\$36.50
B16G14	16"	\$37.50
B18G14	18"	\$48.75
B20G14	20"	\$54.75

TOM & SNARE SINGLE-PLY HEADS



J1™ Etched

J for “Jazz,” these 10mil single-ply heads have an etched finish that’s ideal for brushes but doesn’t chip away under sticks. With maximized sustain and frequency balance, the J1 emits a natural earthiness. Excellent option for tom resonant heads.

(single-ply, 10mil)

Item #	Diameter	Retail
E10J1	10”	\$31.25
E12J1	12”	\$32.25
E13J1	13”	\$35.00
E14J1	14”	\$37.25
E15J1	15”	\$39.25
E16J1	16”	\$42.25



Strata™ 1000 Concert Tom

As the mid-range voice within the Strata family, a calfskin-colored coating provides the 10mil Strata 1000 Concert Tom heads with a warm, round tone and a darker fundamental.

Coated (single-ply, 10mil)

Item #	Diameter	Retail
CT06S	6”	\$25.00
CT08S	8”	\$26.50
CT10S	10”	\$27.50
CT12S	12”	\$28.50
CT13S	13”	\$30.75
CT14S	14”	\$31.75
CT15S	15”	\$36.25
CT16S	16”	\$41.50
CT18S	18”	\$58.25

TOM & SNARE TWO-PLY HEADS



TOP★SELLER

G2™

A two-ply head featuring consistency and durability, the G2 offers the perfect blend of depth, sustain, and attack. It makes small toms sing and floor toms growl.

Clear (two-ply, 7mil +7mil)

Item #	Diameter	Retail
TT06G2	6”	\$26.25
TT08G2	8”	\$27.25
TT10G2	10”	\$28.25
TT12G2	12”	\$29.25
TT13G2	13”	\$31.50
TT14G2	14”	\$33.00
TT15G2	15”	\$36.50
TT16G2	16”	\$37.50
TT18G2	18”	\$48.75
TT20G2	20”	\$54.75

Coated (two-ply, 7mil +7mil)

Item #	Diameter	Retail
B06G2	6”	\$26.25
B08G2	8”	\$27.25
B10G2	10”	\$28.25
B12G2	12”	\$29.25
B13G2	13”	\$31.50
B14G2	14”	\$33.00
B15G2	15”	\$36.50
B16G2	16”	\$37.50
B18G2	18”	\$48.75
B20G2	20”	\$54.75



Onyx™

Onyx heads are designed with two plies of 7.5mil film that will deliver enhanced durability while making the drums cut live. A frost coating gives the Onyx heads a matte black appearance and increases low-end response and attack. The Onyx tom heads are pitch black and rock solid.

Frosted (two-ply, 7.5mil +7.5mil)

Item #	Diameter	Retail
B06ONX2	6”	\$34.00
B08ONX2	8”	\$35.00
B10ONX2	10”	\$36.25
B12ONX2	12”	\$38.25
B13ONX2	13”	\$41.00

Frosted (two-ply, 7.5mil +7.5mil)

Item #	Diameter	Retail
B14ONX2	14”	\$43.25
B15ONX2	15”	\$47.75
B16ONX2	16”	\$49.00
B18ONX2	18”	\$65.25
B20ONX2	20”	\$71.75



TOP★SELLER

Black Chrome™

Black Chrome batter heads feature a two-ply construction with a top ply of 7mil optically clear film over a 7.5mil black film to create a black mirror-like aesthetic. The opposing film combination provides a robust tone with accentuated mid-to-low frequency response. Black Chromes are ideal for progressive rock and metal drummers looking for a deep sound with an articulate attack and reliable durability.

(two-ply, 7mil +7.5mil)

Item #	Diameter	Retail
TT06CHR	6”	\$34.00
TT08CHR	8”	\$35.00
TT10CHR	10”	\$36.25
TT12CHR	12”	\$38.25
TT13CHR	13”	\$41.00

(two-ply, 7mil +7.5mil)

Item #	Diameter	Retail
TT14CHR	14”	\$43.25
TT15CHR	15”	\$47.75
TT16CHR	16”	\$49.00
TT18CHR	18”	\$64.25
TT20CHR	20”	\$72.75

TOM & SNARE TWO-PLY HEADS



TOP★SELLER

EC2S™

EC2S tom heads feature Sound Shaping Technology (SST™), a new ink-based damping technique that ensures optimized performance for each individually sized drumhead. Made using two plies of 7mil film, the new design increases attack, tone, length of sustain, and ease of tuning for each head size – delivering a more balanced and pre-EQ'd sound across the full kit. *US Patent # 7,214,867

Clear (two-ply, 7mil +7mil)

Item #	Diameter	Retail
TT06EC2S	6"	\$30.50
TT08EC2S	8"	\$31.50
TT10EC2S	10"	\$33.00
TT12EC2S	12"	\$34.25
TT13EC2S	13"	\$36.50
TT14EC2S	14"	\$38.50
TT15EC2S	15"	\$43.25
TT16EC2S	16"	\$43.50
TT18EC2S	18"	\$53.75

Frosted (two-ply, 7mil +7mil)

Item #	Diameter	Retail
B06EC2S	6"	\$30.50
B08EC2S	8"	\$31.50
B10EC2S	10"	\$33.00
B12EC2S	12"	\$34.25
B13EC2S	13"	\$36.50
B14EC2S	14"	\$38.50
B15EC2S	15"	\$43.25
B16EC2S	16"	\$43.50
B18EC2S	18"	\$53.75

TOP★SELLER

Hydraulic™

The Hydraulic series features a thin layer of oil between two plies of film, offering maximum durability and the fat, deep and short sound pioneered by early 70s rock and roll. Hydraulics are famously easy to tune, making them a perfect fix for troublesome drums and players with little tuning experience.



Hydraulic Blue (7mil+7mil)

Item #	Diameter	Retail
TT06HB	6"	\$30.25
TT08HB	8"	\$31.25
TT10HB	10"	\$32.75
TT12HB	12"	\$35.00
TT13HB	13"	\$37.00
TT14HB	14"	\$39.50
TT15HB	15"	\$41.75
TT16HB	16"	\$43.75
TT18HB	18"	\$52.25
TT20HB	20"	\$64.00



Hydraulic Red (7mil+7mil)

Item #	Diameter	Retail
TT06HR	6"	\$30.25
TT08HR	8"	\$31.25
TT10HR	10"	\$32.75
TT12HR	12"	\$35.00
TT13HR	13"	\$37.00
TT14HR	14"	\$39.50
TT15HR	15"	\$41.75
TT16HR	16"	\$43.75
TT18HR	18"	\$52.25
TT20HR	20"	\$64.00



Hydraulic Glass (6.5mil+6.5mil)

Item #	Diameter	Retail
TT06HG	6"	\$30.25
TT08HG	8"	\$31.25
TT10HG	10"	\$32.75
TT12HG	12"	\$35.00
TT13HG	13"	\$37.00
TT14HG	14"	\$39.50
TT15HG	15"	\$41.75
TT16HG	16"	\$43.75
TT18HG	18"	\$52.25
TT20HG	20"	\$64.00



Hydraulic Black (6.5mil+7.5mil)

Item #	Diameter	Retail
TT06HBG	6"	\$30.25
TT08HBG	8"	\$31.25
TT10HBG	10"	\$32.75
TT12HBG	12"	\$35.00
TT13HBG	13"	\$37.00
TT14HBG	14"	\$39.50
TT15HBG	15"	\$41.75
TT16HBG	16"	\$43.75
TT18HBG	18"	\$52.25
TT20HBG	20"	\$64.00



If there's one instrument Square Peg Round Hole is unapologetically picky about, it's the floor tom. We have three floor toms in our setup, and thunderous, hocketing tom rhythms have become a strong part of our musical identity. It is virtually impossible for the Hydraulic Glass head to sound bad on our toms. The minute we threw them on for the first time, they already delivered the pure, present, and deep tone that we are constantly looking for. These heads have the perfect ratio of attack to resonance, and have a clear tone without producing unnecessary overtones.

Square Peg Round Hole



TOP★SELLER

Reso 7

The Reso 7 coated resonant head is designed to provide a warm, full tone combined with a shortened sustain for increased clarity and control.

Coated (7mil)

Item #	Diameter	Retail
B06RES7	6"	\$30.50
B08RES7	8"	\$31.50
B10RES7	10"	\$33.00
B12RES7	12"	\$34.25
B13RES7	13"	\$36.50

Coated (7mil)

Item #	Diameter	Retail
B14RES7	14"	\$38.50
B15RES7	15"	\$42.25
B16RES7	16"	\$43.50
B18RES7	18"	\$52.50



Genera™ Resonant

Genera Resonants have brighter overtones than G1. The line offers bright, open sustain with any batter head.

Clear (10mil)

Item #	Diameter	Retail
TT06GR	6"	\$26.25
TT08GR	8"	\$27.25
TT10GR	10"	\$28.25
TT12GR	12"	\$29.25
TT13GR	13"	\$31.50

Clear (10mil)

Item #	Diameter	Retail
TT14GR	14"	\$33.00
TT15GR	15"	\$35.50
TT16GR	16"	\$37.50
TT18GR	18"	\$47.50



Resonant Glass and Black

Resonant Glass and Black heads are some of the thinnest resonant heads we make. When used with either a single- or two-ply head, they will increase attack and shorten sustain.

Resonant Glass (6.5mil)

Item #	Diameter	Retail
TT06RGL	6"	\$26.25
TT08RGL	8"	\$27.25
TT10RGL	10"	\$28.25
TT12RGL	12"	\$29.25
TT13RGL	13"	\$31.50
TT14RGL	14"	\$33.00
TT15RGL	15"	\$35.50
TT16RGL	16"	\$37.50
TT18RGL	18"	\$47.50

Resonant Black (7.5mil)

Item #	Diameter	Retail
TT06RBG	6"	\$30.50
TT08RBG	8"	\$31.50
TT10RBG	10"	\$33.00
TT12RBG	12"	\$34.25
TT13RBG	13"	\$36.50
TT14RBG	14"	\$38.50
TT15RBG	15"	\$41.25
TT16RBG	16"	\$43.50
TT18RBG	18"	\$54.00



TOP★SELLER

EC™ Resonant

The EC Resonant has the ability to control and correct tuning inconsistencies while offering a more centered pitch, increased resonance and dynamic range, and enhanced projection. Made with a 10mil ultra-clear film that provides a mid-range frequency bump, the EC Resonant highlights the natural sound of the drum.

*US Patent # 7,214,867

(10mil)

Item #	Diameter	Retail
TT06ECR	6"	\$30.50
TT08ECR	8"	\$31.50
TT10ECR	10"	\$33.00
TT12ECR	12"	\$34.25
TT13ECR	13"	\$36.50

(10mil)

Item #	Diameter	Retail
TT14ECR	14"	\$38.50
TT15ECR	15"	\$42.25
TT16ECR	16"	\$43.50
TT18ECR	18"	\$52.50

DID YOU KNOW

the G1 can also be used as a resonant head? (see page 106)



EC Resonant: Great resonant heads giving a full, round tone to the drum.

Glenn Kotche

TOM PACKS & PRO PACKS



Tom Packs & Pro Packs

Save more when buying our most popular tom head offerings in bundled packages for fusion (10", 12", 14"), rock (10", 12", 16"), and standard (12", 13", 16") configurations. Pro Packs include the added value of a 14" snare batter.

Tom Packs

Fusion Packs (10", 12", 14")

NEW!

Description	Item #	Retail
G1 Clear	ETP-G1CLR-F	\$81.75
G1 Coated	ETP-G1CTD-F	\$81.75
UV1 Coated	ETP-UV1-F	\$98.00
G2 Clear	ETP-G2CLR-F	\$81.75
G2 Coated	ETP-G2CTD-F	\$81.75
EC2 Clear	ETP-EC2SCLR-F	\$94.50
EC2 Frosted	ETP-EC2SCTD-F	\$94.50
Hydraulic	ETP-HYDGL-F	\$91.25
Onyx	ETP-ONX2-F	\$103.75
Black Chrome	ETP-CHR-F	\$107.00

Rock Packs (10", 12", 16")

NEW!

Description	Item #	Retail
G1 Clear	ETP-G1CLR-R	\$85.50
G1 Coated	ETP-G1CTD-R	\$85.50
UV1 Coated	ETP-UV1-R	\$102.50
G2 Clear	ETP-G2CLR-R	\$85.50
G2 Coated	ETP-G2CTD-R	\$85.50
EC2 Clear	ETP-EC2SCLR-R	\$102.75
EC2 Frosted	ETP-EC2SCTD-R	\$102.75
Hydraulic	ETP-HYDGL-R	\$96.00
Onyx	ETP-ONX2-R	\$108.75
Black Chrome	ETP-CHR-R	\$110.50

Standard Packs (12", 13", 16")

NEW!

Description	Item #	Retail
G1 Clear	ETP-G1CLR-S	\$87.50
G1 Coated	ETP-G1CTD-S	\$87.50
UV1 Coated	ETP-UV1-S	\$105.75
G2 Clear	ETP-G2CLR-S	\$87.50
G2 Coated	ETP-G2CTD-S	\$87.50
EC2 Clear	ETP-EC2SCLR-S	\$102.75
EC2 Frosted	ETP-EC2SCTD-S	\$102.75
Hydraulic	ETP-HYDGL-S	\$99.25
Onyx	ETP-ONX2-S	\$115.25
Black Chrome	ETP-CHR-S	\$113.75

GREATEST★VALUE

NEW! Pro Packs

G2 Clear

Description	Item #	Retail
G2 Clear with 14" HD Dry Snare - Fusion	EPP-G2HDD-F	\$110.00
G2 Clear with 14" HD Dry Snare - Rock	EPP-G2HDD-R	\$116.00
G2 Clear with 14" HD Dry Snare - Standard	EPP-G2HDD-S	\$120.00

UV1 Coated

Description	Item #	Retail
UV1 Coated with 14" UV1 Snare - Fusion	EPP-UV1-F	\$132.00
UV1 Coated with 14" UV1 Snare - Rock	EPP-UV1-R	\$136.00
UV1 Coated with 14" UV1 Snare - Standard	EPP-UV1-S	\$139.95

EC2S Clear

Description	Item #	Retail
EC2S Clear with 14" HD Dry Snare - Fusion	EPP-EC2SHDD-F	\$126.25
EC2S Clear with 14" HD Dry Snare - Rock	EPP-EC2SHDD-R	\$132.50
EC2S Clear with 14" HD Dry Snare - Standard	EPP-EC2SHDD-S	\$136.50

Hydraulic Red

Description	Item #	Retail
Hydraulic Red with 14" UV1 Snare - Fusion	EPP-HRUV1-F	\$132.00
Hydraulic Red with 14" UV1 Snare - Rock	EPP-HRUV1-R	\$136.00
Hydraulic Red with 14" UV1 Snare - Standard	EPP-HRUV1-S	\$140.00



Black Chrome tom heads provide a warm tone with powerful attack, and are able to endure a punishing tour schedule.

Jay Weinberg, Slipknot



FOR ADDED DURABILITY & FOCUS

TOP★SELLER

Power Center™

The 10mil single-ply Power Center offers durability and focus in the center with a 5mil patch. Unique slots in the 5" diameter dot allow it to flex, keeping the head open at the edges. The Reverse Dot head moves the dot to the underside, and out of the way for brushes. *US Patent #5,986,196

Power Center
(single-ply, 10mil+5mil patch)

Item #	Diameter	Retail
B13G1D	13"	\$35.00
B14G1D	14"	\$38.50

Power Center Reverse Dot
(single-ply, 10mil+5mil reverse dot)

Item #	Diameter	Retail
B10G1RD	10"	\$31.25
B12G1RD	12"	\$32.25
B13G1RD	13"	\$35.00
B14G1RD	14"	\$38.50



FOR THE HEAVIEST HITTERS

TOP★SELLER

Heavyweight Snare

The Heavyweight Snare batter features two identical plies of high-performance 10mil film with a 3mil reverse dot patch to provide maximum durability with a compressed attack and short sustain.

(two-ply, 10mil+10mil+3mil reverse dot)

Item #	Diameter	Retail
B12HW	12"	\$38.25
B13HW	13"	\$41.00
B14HW	14"	\$43.25

The Heavyweight snare head has the ability to be tuned to ear-splitting tension, allowing for fast response & full-bodied tone.

Jay Weinberg, Slipknot



TOP★SELLER

Genera™ and Genera™ Dry

This classic Evans head is 10mil single-ply with the fat sound of a two-ply, featuring a 2mil overtone control ring on the underside that "floats" with the head, suppressing excessive overtones and controlling sustain. Genera Dry features small vent holes around the edge that eliminate stray harmonics and tighten the sound.

Genera (10mil+2mil control ring)

Item #	Diameter	Retail
B13GEN	13"	\$35.00
B14GEN	14"	\$37.25

Genera Dry
(10mil+2mil control ring + vents)

Item #	Diameter	Retail
B12DRY	12"	\$32.25
B13DRY	13"	\$35.00
B14DRY	14"	\$37.25



TOP★SELLER

HD™ (Heavy Duty) and HD™ Dry

The HD is a durable two-ply (5mil external, 7.5mil internal) that barks live, yet is ideal for the studio. HD Dry features small vent holes around the edge that eliminate stray harmonics and tighten the sound.

HD (5mil+7.5mil+2mil control ring)

Item #	Diameter	Retail
B12HD	12"	\$34.25
B13HD	13"	\$36.50
B14HD	14"	\$38.50

HD Dry (5mil+7.5mil+2mil control ring + vents)

Item #	Diameter	Retail
B12HDD	12"	\$34.25
B13HDD	13"	\$36.50
B14HDD	14"	\$38.50



ST™ (Super Tough) and ST™ Dry

Packing two layers of 7.5mil film, the ST promotes durability and a full bandwidth rimshot. It delivers all the volume and ring needed, yet amazingly responds to the flick of a fingernail. On the "Dry" version, small vent holes around the edge eliminate stray harmonics and tighten the sound.

ST (two-ply, 7.5mil+7.5mil)

Item #	Diameter	Retail
B13ST	13"	\$36.50
B14ST	14"	\$38.50

ST Dry (two-ply, 7.5mil+7.5mil+vents)

Item #	Diameter	Retail
B13STD	13"	\$36.50
B14STD	14"	\$38.50

SNARE & SNARE SIDE HEADS



EC (Edge Control)

EC snare heads combine Evans' Edge Control technology that pre-EQs the sound, removing troublesome mid-range overtones that muddy the snare drum's sound. The addition of a specially designed patch on the Reverse Dot models lends extra durability, focus, and attack in the center.

*US Patent # 7,214,867

EC (two-ply, 7mil+10mil)

Item #	Diameter	Retail
B10ECS	10"	\$35.50
B12ECS	12"	\$37.50
B13ECS	13"	\$39.50
B14ECS	14"	\$42.50



EC1 Reverse Dot

(single-ply, 14mil+3mil reverse dot)

Item #	Diameter	Retail
B13EC1RD	13"	\$39.50
B14EC1RD	14"	\$42.50



Hydraulic Snare Batter

The classic Evans Hydraulic in a coated version for snare use. With short sustain and superb durability, this head is a blanket cure for troublesome snare drums and reflective rooms.

Hydraulic Black Snare Coated
(two-ply, 6.5mil+7.5mil)

Item #	Diameter	Retail
B14HBG	14"	\$41.00

Hydraulic Blue Snare Coated
(two-ply, 7mil+7mil)

Item #	Diameter	Retail
B14HB	14"	\$41.00



Hybrid™ Coated Drum Set Snare

By utilizing two unique high-tensile fibers, one chosen for flexibility and the other for durability, the Hybrid snare batter achieves greater snare response and dynamic range, while maintaining the extreme durability and accentuated attack preferred by the hardest hitters.

(single-ply)

Item #	Diameter	Retail
B13MHG	13"	\$119.75
B14MHG	14"	\$130.00



Snare Side 200

The 2mil Snare Side 200 will enhance sensitivity for softer dynamics and brushwork while reducing sustain for greater articulation.

(2mil)

Item #	Diameter	Retail
S10H20	10"	\$26.25
S12H20	12"	\$28.25
S13H20	13"	\$28.25
S14H20	14"	\$30.50

FOR
PURESOUND
SNARE WIRES
SEE PAGES
127-128

TOP★SELLER

Snare Side 300

The 300 is Evans' most versatile snare side head. The 3mil film yields a wide dynamic range and controlled snare response at all dynamic levels.

(3mil)

Item #	Diameter	Retail
S08H30	8"	\$26.25
S10H30	10"	\$26.25
S12H30	12"	\$28.25
S13H30	13"	\$28.25
S14H30	14"	\$30.50
S15H30	15"	\$33.50

Snare Side 500

The 5mil Snare Side 500 produces a dark, throaty sound that is best suited for deep drums or heavy rock performances.

(5mil)

Item #	Diameter	Retail
S13R50	13"	\$28.25
S14R50	14"	\$30.50



\$AVE

Snare Head Bulk 10-Packs

Item #	Description	Retail	Item #	Description	Retail
B14G1-B	14" G1 Coated	\$33.00	B14G1RD-B	14" Power Center Reverse Dot Coated	\$38.50
B14G2-B	14" G2 Coated	\$33.00	B14DRY-B	14" Genera Dry Coated	\$37.25
B14G14-B	14" G14 Coated	\$33.00	B14HDD-B	14" HD Dry Coated	\$38.50
B14G1D-B	14" Power Center Coated	\$38.50	B14ST-B	14" ST Coated	\$38.50
			S14H30-B	14" Snare Side 300	\$30.50



Choice of
2 foam rings

EMAD™

Tailor degrees of damping and attack without removing the head or reaching inside the drum. is a 10mil single-ply head with two interchangeable damping rings that maximize attack and low-end. The coating adds additional warmth, focus, and depth. The GMAD is a 12mil single-ply version of the original EMAD that adds punch, low-end, and 20% extra durability. The EMAD2 has an outer ply of 6.5mil and an inner ply of 10mil to enhance attack, focus, and durability.

*US Patent# 6,291,754



EMAD™ Heavyweight

The EMAD Heavyweight features two identical plies of high-performance 10mil film combined with the groundbreaking EMAD system to provide maximum attack, low-frequency response, and ultimate durability.



EMAD™ Onyx

The EMAD Onyx utilizes a single-ply of 10mil black film with an improved EMAD damping ring and a frosted coating that produces an extra dark sound while delivering additional punch. It's the perfect aesthetic and sonic compliment to the Onyx tom heads and bass resonant.



EQ3™

The two-ply EQ3 with an internal overtone control ring and removable muffle ring puts the "kick" back in kick drum. Controlled low-end rumble and focused attack make it the perfect live head. Due to its two plies, it will not distort under heavy hitting. The coated version lends a little warmth.



TOP★SELLER

EQ4™

Providing optimum slap without sacrificing bottom end, you kick the EQ4 and it kicks back! A special film makes this 10mil single-ply extra rugged and the width of the fixed internal ring is proportional to the head size, optimizing control from 16" to 26".

EMAD Clear (single-ply, 10mil)

Item #	Diameter	Retail
TT16EMAD	16"	\$89.00
BD16EMAD	16"	\$89.00
BD18EMAD	18"	\$93.50
BD20EMAD	20"	\$98.00
BD22EMAD	22"	\$102.75
BD24EMAD	24"	\$108.75
BD26EMAD	26"	\$118.00

EMAD Coated (single-ply, 10mil)

Item #	Diameter	Retail
BD18EMADCW	18"	\$93.50
BD20EMADCW	20"	\$98.00
BD22EMADCW	22"	\$102.75
BD24EMADCW	24"	\$108.75
BD26EMADCW	26"	\$118.00

Clear (two-ply, 10mil+10mil)

Item #	Diameter	Retail
BD18EMADHW	18"	\$93.50
BD20EMADHW	20"	\$98.00
BD22EMADHW	22"	\$102.75
BD24EMADHW	24"	\$108.75
BD26EMADHW	26"	\$118.00

Frosted (single-ply 10mil)

Item #	Diameter	Retail
BD18EMADONX	18"	\$98.25
BD20EMADONX	20"	\$101.25
BD22EMADONX	22"	\$108.25
BD24EMADONX	24"	\$124.00
BD26EMADONX	26"	\$140.75

Clear (two-ply, 6.5mil+6.5mil+10mil ring)

Item #	Diameter	Retail
BD18GB3	18"	\$93.75
BD20GB3	20"	\$98.50
BD22GB3	22"	\$107.00
BD24GB3	24"	\$116.25
BD26GB3	26"	\$123.50

Clear (10mil+10mil ring)

Item #	Diameter	Retail
TT16GB4	16"	\$66.75
BD16GB4	16"	\$66.75
BD18GB4	18"	\$71.25
BD20GB4	20"	\$75.50
BD22GB4	22"	\$81.50
BD24GB4	24"	\$87.25
BD26GB4	26"	\$94.75

GMAD Clear (single-ply, 12mil)

Item #	Diameter	Retail
BD18GMAD	18"	\$93.50
BD20GMAD	20"	\$98.00
BD22GMAD	22"	\$102.75
BD24GMAD	24"	\$108.75
BD26GMAD	26"	\$118.00

TOP★SELLER

EMAD2 Clear (6.5mil + 10mil)

Item #	Diameter	Retail
BD18EMAD2	18"	\$93.50
BD20EMAD2	20"	\$98.00
BD22EMAD2	22"	\$102.75
BD24EMAD2	24"	\$108.75
BD26EMAD2	26"	\$118.00



I love the durability, sensitivity, and tonal response that Heavyweight provides. Kenny Aronoff, John Fogerty

Frosted (two-ply, 6.5mil+6.5mil+10mil ring)

Item #	Diameter	Retail
BD18GB3C	18"	\$93.75
BD20GB3C	20"	\$98.50
BD22GB3C	22"	\$107.00
BD24GB3C	24"	\$116.25
BD26GB3C	26"	\$123.50

Frosted (10mil+10mil ring)

Item #	Diameter	Retail
BD18GB4C	18"	\$71.25
BD20GB4C	20"	\$75.50
BD22GB4C	22"	\$81.50
BD24GB4C	24"	\$87.25
BD26GB4C	26"	\$94.75

BASS BATTER HEADS



NEW! UV1

The UV1 series is designed for the widest range of sonic possibilities while remaining the most durable single-ply drumhead available. The patented UV-cured coating provides unmatched durability and consistency of texture, while the unique 10mil film delivers exceptional strength and versatility for a full range of musical applications. Standard UV1s feature the same durable 10mil, single-ply film featured on the tom heads. The UV EQ4 has a fixed internal overtone control ring that reduces sustain and focuses the tonal response of the drum, while the EMAD version has the benefit of adjustable damping for added attack and focus.

UV1

(single-ply, 10mil)

Item #	Diameter	Retail
B16UV1	16"	\$39.75
BD16UV1	16"	\$80.00
BD18UV1	18"	\$82.75
BD20UV1	20"	\$86.00
BD22UV1	22"	\$91.25
BD24UV1	24"	\$97.50

UV EQ4

(single-ply, 10mil+10mil ring)

Item #	Diameter	Retail
B16GB4UV	16"	\$80.00
BD16GB4UV	16"	\$80.00
BD18GB4UV	18"	\$85.00
BD20GB4UV	20"	\$90.00
BD22GB4UV	22"	\$97.50
BD24GB4UV	24"	\$105.00
BD26GB4UV	26"	\$115.00

UV EMAD

(single-ply, 10mil)

Item #	Diameter	Retail
B16UVEMAD	16"	\$95.00
BD16UVEMAD	16"	\$95.00
BD18UVEMAD	18"	\$100.00
BD20UVEMAD	20"	\$107.50
BD22UVEMAD	22"	\$115.00
BD24UVEMAD	24"	\$125.00
BD26UVEMAD	26"	\$135.00

Calf-tone

Calf-tone drumheads are a synthetic alternative to traditional calfskin. They embody the look and sound of a natural skin but with the consistency, fit, and tuning range made standard with Level 360 Technology™. These heads bring out the best of a vintage kit and evoke a classic appearance and sound from modern drums. Calf-tone bass heads are made using a 12mil film base blended with unique materials to produce warm, full, and rich tones. As an EQ4, a fixed internal overtone control ring helps focus the tonal response of the drum. Combined with EMAD features, these heads have the benefit of adjustable damping for added attack and focus. Standard Calf-tone and EQ4 Calf-tone can be used as either a batter or resonant head.



Calf-tone

(single-ply, 12mil+7.5mil)

Item #	Diameter	Retail
TT16CT	16"	\$42.50
BD16CT	16"	\$72.50
BD18CT	18"	\$75.00
BD20CT	20"	\$78.25
BD22CT	22"	\$82.75
BD24CT	24"	\$89.00
BD26CT	26"	\$95.25

EQ4 Calf-tone

(single-ply, 12mil+7.5mil+10mil ring)

Item #	Diameter	Retail
TT16GB4CT	16"	\$75.00
BD16GB4CT	16"	\$75.00
BD18GB4CT	18"	\$78.25
BD20GB4CT	20"	\$82.75
BD22GB4CT	22"	\$89.25
BD24GB4CT	24"	\$94.75
BD26GB4CT	26"	\$103.50

EMAD Calf-tone

(single-ply, 12mil+7.5mil)

Item #	Diameter	Retail
TT16EMADCT	16"	\$97.75
BD16EMADCT	16"	\$97.75
BD18EMADCT	18"	\$102.50
BD20EMADCT	20"	\$107.75
BD22EMADCT	22"	\$112.75
BD24EMADCT	24"	\$119.00
BD26EMADCT	26"	\$129.50



G1™

A starting point in traditional bass drum sounds, the G1 is a 10mil single-ply head that provides bright attack, warm sustain, and a broad tuning range. Can also be used as a resonant head.

Clear (single-ply, 10mil)

Item #	Diameter	Retail
BD18G1	18"	\$68.50
BD20G1	20"	\$71.25
BD22G1	22"	\$75.50

Coated White (single-ply, 10mil)

Item #	Diameter	Retail
BD16G1CW	16"	\$66.25
BD18G1CW	18"	\$68.50
BD20G1CW	20"	\$71.25
BD22G1CW	22"	\$75.50



G2™

The two 7mil plies of the G2 bass head offer maximum durability with wide-open response and undeniably fat low-end. A modern, full resonance you can tailor to taste.

Clear (two-ply, 7mil+7mil)

Item #	Diameter	Retail
BD20G2	20"	\$71.25
BD22G2	22"	\$75.50

Coated White (two-ply, 7mil+7mil)

Item #	Diameter	Retail
BD20G2CW	20"	\$71.25
BD22G2CW	22"	\$75.50



EMAD Heavyweight is the perfect balance of tonality and durability.
Matt Halpern,
Periphery

BASS BATTER HEADS



Hydraulic™

A classic sound, short in sustain. Tension it tight for a real thump or loose and slappy. Two plies sandwich a thin film of oil that suppresses unwanted overtones.

Hydraulic Blue (7mil+7mil)

Item #	Diameter	Retail
BD20HB	20"	\$77.00
BD22HB	22"	\$81.50

Hydraulic Red (7mil+7mil)

Item #	Diameter	Retail
BD20HR	20"	\$77.00
BD22HR	22"	\$81.50

Hydraulic Black (6.5mil+7.5mil)

Item #	Diameter	Retail
BD22HBG	22"	\$81.50

Hydraulic Glass (6.5mil+6.5mil)

Item #	Diameter	Retail
BD22HG	22"	\$81.50

BUNDLE PACKS



\$AVE

EMAD™ System Pack

The EMAD System Pack is a 22" EMAD batter head and a 22" Resonant EMAD head in one convenient package. Designed to deliver the ideal balance of punch, power, and low-end at a reduced price compared to buying the heads individually.

Item #	Diameter	Retail
EBP-EMADSYS	22"	\$193.70



Heavyweight Knockout Pack

Contains:

- 14" Heavyweight Snare Batter
- 22" EMAD Heavyweight Bass Batter

Item #	Retail
EBP-EMADHW	\$124.25



EQ3™ Bass Head Set

Contains:

- 1 EQ3 Batter Head
- 1 EQ3 Resonant Head
- 1 EQ Pad
- 1 EQ Patch

Item #	Retail
BD22B3	\$237.95

\$AVE

BASS RESO HEADS



EMAD™ Resonant

A 10mil head with a fixed internal ring, the EMAD Bass Resonant features an improved ring design. Like the EMAD batter, a black plastic sleeve holds in place a foam damping ring that controls overtones around the edge of the 4" offset port, focusing the pitch and enhancing attack. The ring also provides protection for the mic port.



The redesigned EMAD Resonant Control Ring adds durability, attack, control and low-end.

Frosted (single-ply, 10mil)

Item #	Diameter	Retail
BD18REMAD	18"	\$95.50
BD20REMAD	20"	\$100.25
BD22REMAD	22"	\$107.00
BD24REMAD	24"	\$114.00
BD26REMAD	26"	\$123.50



Resonant Black

A 10mil single-ply head with no rings or vents, the Resonant Black provides a wide-open tone with maximum sustain that's ideal for jazz and bop.

Black (single-ply, 10mil)

Item #	Diameter	Retail
BD18RBG	18"	\$74.75
BD20RBG	20"	\$79.75
BD22RBG	22"	\$85.50



Retro Screen™ Mesh Resonant

Rediscover the punch of a 60s single-headed bass drum sound. The black mesh of the Retro Screen looks good and keeps your shell in round. Zero sympathetic resonance promotes solid oomph!

Item #	Diameter	Retail
BD22SCR	22"	\$85.50



EQ1™ Dry Resonant

This solid resonant head with an internal overtone control ring and dry vents produces a cavernous rumble that is microphone friendly. It also responds with a clean fundamental and a controlled but full sustain when tuned high for jazz and bop.

Smooth Black (10mil+10mil ring + vents)

Item #	Diameter	Retail
BD20RA	20"	\$89.75
BD22RA	22"	\$97.00

BASS RESO HEADS & CUSTOM HEADS



TOP ★ SELLER

EQ3™ Resonant

Featuring the offset 5" hole for internal miking, the EQ3 resonant is the popular choice for both players and engineers. With an internal overtone control ring, this head is made for every miking situation, from the studio to the arena.

DID YOU KNOW

Calf-tone & EQ4 Calf-tone can also be used as a bass reso? (See page 114)



EQ3 Resonant, No Port

The EQ3 Resonant is the popular choice for both players and engineers, featuring a 10mil internal overtone control ring which provides a resonant yet controlled tone with attenuated high-frequency response. The latest addition to the line offers the EQ3 Resonant without a microphone port.

Smooth Black (10mil+10mil ring)

Item #	Diameter	Retail
BD18RB	18"	\$83.75
BD20RB	20"	\$90.25
BD22RB	22"	\$97.00
BD24RB	24"	\$108.50
BD26RB	26"	\$118.75

Onyx (10mil+10mil ring + frost coating)

Item #	Diameter	Retail
BD18RONX	18"	\$89.75
BD20RONX	20"	\$94.75
BD22RONX	22"	\$101.75
BD24RONX	24"	\$113.25
BD26RONX	26"	\$124.75

Smooth White (7.5mil+10mil ring)

Item #	Diameter	Retail
BD18RSW	18"	\$83.75
BD20RSW	20"	\$90.25
BD22RSW	22"	\$97.00
BD24RSW	24"	\$108.50
BD26RSW	26"	\$118.75

Coated White (6.5mil+10mil ring)

Item #	Diameter	Retail
BD18RCW	18"	\$83.75
BD20RCW	20"	\$90.25
BD22RCW	22"	\$97.00
BD24RCW	24"	\$108.50
BD26RCW	26"	\$118.75

Smooth Black (10mil+10mil ring)

Item #	Diameter	Retail
TT16RB-NP	16"	\$77.25
BD16RB-NP	16"	\$77.25
BD18RB-NP	18"	\$83.75
BD20RB-NP	20"	\$90.25
BD22RB-NP	22"	\$97.00
BD24RB-NP	24"	\$108.50
BD26RB-NP	26"	\$118.75

Smooth White (7.5mil+10mil ring)

Item #	Diameter	Retail
TT16RSW-NP	16"	\$77.25
BD16RSW-NP	16"	\$77.25
BD18RSW-NP	18"	\$83.75
BD20RSW-NP	20"	\$90.25
BD22RSW-NP	22"	\$97.00
BD24RSW-NP	24"	\$108.50
BD26RSW-NP	26"	\$118.75

Coated White (6.5mil+10mil ring)

Item #	Diameter	Retail
BD18RCW-NP	18"	\$83.75
BD20RCW-NP	20"	\$90.25
BD22RCW-NP	22"	\$97.00
BD24RCW-NP	24"	\$108.50
BD26RCW-NP	26"	\$118.75

INKED BY EVANS

Custom Bass Heads & Custom Marching Bass Heads

Inked by Evans Custom Bass Drumheads are made using a high-resolution printing system, resulting in photo-quality images. Instead of printing and applying a laminate like many other custom bass heads, the image is printed directly onto the drumhead, resulting in an uncompromised sound.

- Easy-to-use online interface
- Customizable printing technology
- Multi-graphic options
- 2-week turnaround time
- Available worldwide

Visit inkedbyevans.com to view:

- Licensed designs by well-known music artists and graphic designers
- Interesting textures, nature scenes, abstract photography, and clever graphics
- Or upload your own art!

CREATE YOUR OWN CUSTOM DESIGN WITH THE INKED BY EVANS GIFT CARD



Custom Bass Heads Available in sizes 18-26"



Custom Marching Bass Heads Available MX or MS in sizes 14-32"



Inked by Evans Gift Card

Sell custom bass heads over the counter with the Inked by Evans gift card!

Not valid on marching bass heads.

Item #	Diameter	Retail
INKCARDB	18" - 26"	\$180.25

AFRO CUBAN & CONGA HEADS



Tri-Center™ Bongo

The Tri-Center Bongo heads deliver a bright, penetrating slap with a full, round bottom end, and feature a natural-feeling coating which simulates the touch and response of a natural head. A new tooth-grip extruded hoop*, combined with laser cuts** around the collar, ensures a clean look, precision tuning, and flawless performances at high tension, while the Tri-Center dot removes unwanted overtones and enhances the fundamental.

Item #	Description	Retail
EB07	7-1/4"	\$77.00
EB09	8-5/8"	\$79.75

Fits: LP® Valje & Generation II, Meinl Fibercraft & Wood FWB400, Toca® 4500 & 4600

Bongo Combo Pack

Get both heads at one economical price with this combo pack.

Item #	Description	Retail
EB0709	7-1/4" and 8-5/8" (1 each)	\$140.00

J1™ Etched For Timbale

These single-ply, 10mil heads have a specially etched finish that combines the sustain of an uncoated head with the warmth of a traditional coating. The Evans J1 head delivers a brilliant rimshot without sacrificing depth and is warm and dense in the center with a full sustain at the edges.



(single-ply, 10mil)

Item #	Diameter	Retail
E10J1	10"	\$31.25
E12J1	12"	\$32.25
E13J1	13"	\$35.00
E14J1	14"	\$37.25
E15J1	15"	\$39.25
E16J1	16"	\$42.25

Fits most manufacturers' timbales.
Specifications subject to change without notice.

*US Patent #6,350,941

**US Patent #6,184,451



Tri-Center™ Conga

Evans conga heads provide superior tone, reliable durability, and unsurpassed resistance to climatic and temperature changes. A tapered hoop* provides better fit on out-of-spec drums, and "v"-shaped laser cut** radial slits help seat the head. The Tri-Center dot removes unwanted overtones and adds weight to the center, thus dropping the fundamental frequency and producing more low-end.

For LP® Classic Models with "Comfort Curve" Hoop

Item #	Description	Retail
EC1100	Fits 11" LP Professional Series	\$118.75
EC1175	Fits 11-3/4" LP Professional Series	\$121.00
EC1250	Fits 12-1/2" LP Professional Series	\$123.50

Fits Classic/Salsa/Valje (tight fit)/Gio Old Models/Original & Patato Fiberglass/Old Galaxy® Fiberglass

EC1100 also serves as a replacement head for LP's Compact Conga

For LP® Giovanni Models with "Comfort Curve" Hoop

Item #	Description	Retail
EC0975	Fits LP 9-3/4" Requinto	\$116.25
EC1100E	Fits LP 11" Conga	\$118.75
EC1175E	Fits LP 11-3/4" Conga	\$121.00
EC1250E	Fits LP 12-1/2" Conga	\$123.50

For Toca® Professional Models with "Easy Play" Hoop

Item #	Description	Retail
EC1100	Fits 11" Toca Professional Series	\$118.75
EC1175	Fits 11-3/4" Toca Professional Series	\$121.00
EC1250	Fits 12-1/2" Toca Professional Series	\$123.50

Fits Limited Edition (LE), Custom Deluxe, and Premier models

For 11-3/4" Premier, use EC1175E



The consistency and quality of Evans heads help me achieve the best sounds under any conditions.

Giovanni Hidalgo

PIPE BAND HEADS



NEW! Pipe Band Snare Batter

Designed in collaboration with Stephen Creighton, the Evans Pipe Band Snare Head was designed to meet the rigorous demands of the modern snare drummer while also catering to the traditionalists. Previously, pipe band drummers had to choose between a head that offered a bright and articulate sound for solo performances and a heavier head for more projection in outdoor settings. The Evans Pipe Band Snare batter offers the best of both worlds which drummers can appreciate on and off the green.

Item #	Diameter	Retail
PB-SB1A	14" (Oversized)	\$102.50
PB-SB1B	14" (Standard)	\$102.50



Snare Side 300

3mil snare side head for a bright and articulate tone. The snare side head of choice for Stephen Creighton and the St. Laurence O'Toole Pipe Band.

Item #	Diameter	Retail
S14H30	14"	\$30.50



The new Evans Pipe Band snare head is by far the best head I have ever played on. With its crystal clear clarity, unmatched durability, and ability to maintain pitch and tone, I could play this head all day!
Stephen Creighton

MARCHING SNARE BATTER



NEW! System Blue Marching Snare

The Evans System Blue snare head was designed in collaboration with Scott Johnson of the world-renowned Blue Devils Drum and Bugle Corps. It features a softer feel yet maintains the tonal clarity and projection necessary for a championship-winning drum corps. Snare lines will benefit from reduced fatigue during extended rehearsals when using these drumheads.

System Blue Marching Snare		
Item #	Diameter	Retail
SB13MSB	13"	\$129.10
SB14MSB	14"	\$139.40



We've been working on this snare head for years; we now have it. The best feel for the hands and the warmest sound at every dynamic level. System Blue and Evans—the finest in the world of pageantry.
Scott Johnson



Hybrid Series Snare Batter

By utilizing two unique high-tensile fibers for flexibility and durability, the Hybrid marching snare batter achieves a much softer feel, greater sensitivity, and a broader dynamic range while enhancing projection and durability.

Gray Batter			White Batter		
Item #	Diameter	Retail	Item #	Diameter	Retail
SB13MHG	13"	\$129.10	SB13MHW	13"	\$129.10
SB14MHG	14"	\$139.40	SB14MHW	14"	\$139.40



Hybrid-S Soft Series Snare Batter

Inspired by the design of the award-winning Hybrid batter series, the Hybrid-S batter features two unique fibers that, when blended together, deliver a soft and sensitive feel with a warm, full, and tonally rich sound with superior snare response desired by the world's top marching ensembles. Without sacrificing durability, the Hybrid-S achieves a softer feel perfect for younger hands, and wider response that makes smaller lines sound big.

Item #	Diameter	Retail
SB13MHSB	13"	\$116.05
SB14MHSB	14"	\$122.75

MARCHING HEADS

MARCHING SNARE SIDES



Hybrid Series Snare Side

By embedding high-tensile fibers in an open weave pattern between two ultra-thin layers of clear film, the Hybrid marching snare side head produces the sound and sensitivity of a polyester bottom with a resistance to stretch that is closer to Kevlar™.

Gray Batter

Item #	Diameter	Retail
SS13MH1	13"	\$77.75
SS14MH1	14"	\$82.75



MX5™ Snare Side

The 5mil, thin aramid fiber/polyester laminate gives the MX5 maximum snare response, while a thin polyester overtone control ring reinforces the edge durability and eliminates unwanted overtones, further enhancing articulation.

(5mil)

Item #	Diameter	Retail
SS13MX5	13"	\$109.95
SS14MX5	14"	\$114.95



MS3™ Polyester Snare Side

Clear MS3 Polyester snare side heads deliver a dark, rich sound. A 2mil flap helps suppress unwanted overtones while providing reinforcement at the collar to increase longevity.

(3mil)

Item #	Diameter	Retail
SS13MS3C	13"	\$30.25
SS14MS3C	14"	\$31.25

MARCHING TENOR HEADS



System Blue™

Designed in cooperation with the Blue Devils percussion staff, the System Blue tenor head is a two-ply design with 7mil top-ply and 7.5mil bottom. This combination delivers tonal clarity and projection while also increasing durability and pitch stability, reducing the need for frequent tuning. The series also utilizes Evans' unique Sound Shaping Technology™, a damping technique that targets unwanted overtones and provides the control needed to enhance attack, projection, and note definition. The damping pattern on each head also provides a visual reference for the optimal 'playing zone' for each drum, offering a target for less experienced lines.

(7mil+7.5mil)

Item #	Diameter	Retail
TT06SB1	6"	\$33.60
TT08SB1	8"	\$34.70
TT10SB1	10"	\$35.80

(7mil+7.5mil)

Item #	Diameter	Retail
TT12SB1	12"	\$38.90
TT13SB1	13"	\$41.35
TT14SB1	14"	\$43.60



Corps Clear™

The two-ply design with 6.5mil top-ply and 10mil bottom-ply not only delivers clarity of tone over the drum, but enables the drums to cut through the ensemble in clear and discernible pitches to reach out front and into the stands. The extra thickness (16.5mil total) compared to standard tenor heads (14-15mil total) makes the Corps Clear more durable, which not only prolongs the life of the head but keeps it in tune longer.

(two-ply, 6.5mil+10mil)

Item #	Diameter	Retail
TT06CC	6"	\$28.00
TT08CC	8"	\$29.00
TT10CC	10"	\$30.25

(two-ply, 6.5mil+10mil)

Item #	Diameter	Retail
TT12CC	12"	\$32.25
TT13CC	13"	\$35.00
TT14CC	14"	\$37.25

MARCHING TENOR & BASS HEADS



MEC2S™ Tenor

The Marching EC2S features two matching plies of 7mil film for greater strength and durability. Sound Shaping Technology™ controls overtones for focused sound. The hoop profile is specially designed to withstand higher tensions and offer greater durability.

(two-ply, 7mil+7mil)

Item #	Diameter	Retail
TT06MEC2S	6"	\$31.50
TT08MEC2S	8"	\$33.00
TT10MEC2S	10"	\$34.25

(two-ply, 7mil+7mil)

Item #	Diameter	Retail
TT12MEC2S	12"	\$36.50
TT13MEC2S	13"	\$38.50
TT14MEC2S	14"	\$41.25



MX™ Tenor

MX Tenor Heads are designed with an advanced hoop concept that prevents pull-out. The MX Frost are made using two 7mil plies of tonally rich and durable film with a unique frosted coating that produces a warm but resonant tone.

MX Black (two-ply, 7.5mil+7.5mil)

Item #	Diameter	Retail
TT06MXB	6"	\$31.50
TT08MXB	8"	\$33.00
TT10MXB	10"	\$34.25
TT12MXB	12"	\$36.50
TT13MXB	13"	\$38.50
TT14MXB	14"	\$41.25

MX Frosted (two-ply, 7mil+7mil)

Item #	Diameter	Retail
TT06MXF	6"	\$31.50
TT08MXF	8"	\$33.00
TT10MXF	10"	\$34.25
TT12MXF	12"	\$36.50
TT13MXF	13"	\$38.50
TT14MXF	14"	\$41.25

MX White (two-ply, 7.5mil+7.5mil)

Item #	Diameter	Retail
TT06MXW	6"	\$31.50
TT08MXW	8"	\$33.00
TT10MXW	10"	\$34.25
TT12MXW	12"	\$36.50
TT13MXW	13"	\$38.50
TT14MXW	14"	\$41.25



MX™ White Bass

The 10mil single-ply MX1 Marching Bass head is equipped with a unique tone-damping system that enhances articulation and focuses low-end. A series of felt damping arcs can be manipulated for indoor or outdoor marching. The MX2 utilizes the same tone-damping system as the MX1, but features two plies of 7.5mil white film for enhanced durability, attack, focus, and projection, ideal for indoor use.

MX1 White (single-ply, 10mil)

Item #	Diameter	Retail
BD14MX1W	14"	\$86.65
BD16MX1W	16"	\$103.55
BD18MX1W	18"	\$111.35
BD20MX1W	20"	\$118.85
BD22MX1W	22"	\$129.10
BD24MX1W	24"	\$139.40
BD26MX1W	26"	\$149.95
BD28MX1W	28"	\$165.20
BD30MX1W	30"	\$183.55
BD32MX1W	32"	\$201.60

MX2 White (two-ply, 7.5mil+7.5mil)

Item #	Diameter	Retail
BD16MX2W	16"	\$103.55
BD18MX2W	18"	\$111.35
BD20MX2W	20"	\$118.85
BD22MX2W	22"	\$129.10
BD24MX2W	24"	\$139.40
BD26MX2W	26"	\$149.95
BD28MX2W	28"	\$165.20
BD30MX2W	30"	\$183.55
BD32MX2W	32"	\$201.60



MX™ Black Bass

The MX Black Bass Heads produce a bright tone and are equipped with the same tone-damping system as the MX White, which enhances articulation and focuses low-end. A series of felt damping arcs can be manipulated for indoor or outdoor marching.

MX1 Black (single-ply, 10mil)

Item #	Diameter	Retail
BD14MX1B	14"	\$95.80
BD16MX1B	16"	\$116.05
BD18MX1B	18"	\$124.10
BD20MX1B	20"	\$131.90
BD22MX1B	22"	\$142.45
BD24MX1B	24"	\$152.70
BD26MX1B	26"	\$163.00
BD28MX1B	28"	\$178.55
BD30MX1B	30"	\$196.60
BD32MX1B	32"	\$214.90

MX2 Black (two-ply, 7.5mil+7.5mil)

Item #	Diameter	Retail
BD16MX2B	16"	\$116.05
BD18MX2B	18"	\$124.10
BD20MX2B	20"	\$131.90
BD22MX2B	22"	\$142.45
BD24MX2B	24"	\$152.70
BD26MX2B	26"	\$163.00
BD28MX2B	28"	\$178.55
BD30MX2B	30"	\$196.60
BD32MX2B	32"	\$214.90



MS1™ White Bass (10mil)

This traditional-sounding, smooth white, 10mil single-ply head gives discerning drummers the option to customize their sound with the damping system of their choice. With durability equal to the MX bass head series, these heads will project warm, musical tones indoors and outdoors. No muffling included.

(single-ply, 10mil)

Item #	Diameter	Retail
BD14MS1W	14"	\$64.25
BD16MS1W	16"	\$72.25
BD18MS1W	18"	\$75.50
BD20MS1W	20"	\$80.50
BD22MS1W	22"	\$88.25

(single-ply, 10mil)

Item #	Diameter	Retail
BD24MS1W	24"	\$97.50
BD26MS1W	26"	\$107.00
BD28MS1W	28"	\$118.75
BD30MS1W	30"	\$130.50
BD32MS1W	32"	\$142.00

CONCERT HEADS

CONCERT SNARE HEADS



Strata™ Concert Snare

The Strata Concert Snare Heads have a natural sustain with midrange overtones that yield a darker timbre with a warm, calfskin-like response. The 700 series is designed for sensitivity and expression, whereas the 1000 series is designed for more robust playing. Strata Staccato comes with a 2mil overtone control ring for increased articulation in either thickness.

Strata 700 (single-ply, 7.5mil)

Item #	Diameter	Retail
CS14S	14"	\$31.50

Strata 1000 (single-ply, 10mil)

Item #	Diameter	Retail
CT14S	14"	\$31.75

Strata Staccato 700 (single-ply, 7.5mil+2mil ring)

Item #	Diameter	Retail
CS14SS	14"	\$37.50

Strata Staccato 1000 (single-ply, 10mil+2mil ring)

Item #	Diameter	Retail
CT14SS	14"	\$37.50



Orchestral Snare

The Orchestral Snare is a thin, 7.5mil head designed for symphonic playing with a warm, open sound and sensitive snare response. The Orchestral Staccato Snare comes with an internal overtone control ring to increase articulation for delicate passages.

Orchestral Snare (single-ply, 7.5mil)

Item #	Diameter	Retail
B14GCS	14"	\$33.00

Orchestral Staccato (single-ply, 7.5mil+ring)

Item #	Diameter	Retail
B14GCSS	14"	\$38.50

Orchestral 200 Side (single-ply, 2mil)

Item #	Diameter	Retail
S14GEN20	14" Resonant	\$30.50

Orchestral 300 Side (single-ply, 3mil)

Item #	Diameter	Retail
S14GEN30	14" Resonant	\$30.50



The Evans Strata Concert Bass Drum heads provide an ensemble with top notch low-end & punch! Also, they hold their pitch incredibly well, even in the most demanding environments.

**Jim Wunderlich,
Blue Devils**

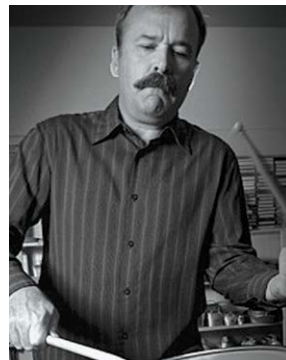

I use Evans Strata heads on all my concert instruments. They provide incredible response and tone. The Level 360 design makes them easy to tune, and gives me more tuning options than ever before.

**Jim Campbell,
University of Kentucky**

CONCERT TOM & BASS HEADS



Strata™ 1000 Concert Tom Heads (10mil)

As the mid-range voice within the Strata family, a calfskin-colored coating provides the 10mil Strata Concert Tom Heads with a warm, round tone and a darker fundamental.

Coated (single-ply, 10mil)

Item #	Diameter	Retail
CT06S	6"	\$25.00
CT08S	8"	\$26.50
CT10S	10"	\$27.50
CT12S	12"	\$28.50
CT13S	13"	\$30.75

Coated (single-ply, 10mil)

Item #	Diameter	Retail
CT14S	14"	\$31.75
CT15S	15"	\$36.25
CT16S	16"	\$41.50
CT18S	18"	\$58.25



Strata™ Concert Bass

The Strata Concert Bass Head is a synthetic head with the appearance, warmth, and full-bodied tone of calfskin. It features mid-range attack with rich depth of sustain and projection. Available with or without a Power Center Dot, which deepens the fundamental.

Strata 1000 (single-ply, 10mil)

Item #	Diameter	Retail
CB2810S	28"	\$184.10
CB3010S	30"	\$193.25
CB3210S	32"	\$205.75
CB3610S	36"	\$225.20
CB4010S	40"	\$244.90

Strata 1400 with Power Center (single-ply, 14mil+5mil patch)

Item #	Diameter	Retail
CB3614SD	36"	\$241.55
CB4014SD	40"	\$262.10

Strata 1400 (single-ply, 14mil)

Item #	Diameter	Retail
CB3614S	36"	\$232.70
CB4014S	40"	\$257.40



Orchestral Timpani Heads

Our Orchestral Timpani heads are pre-tensioned for tuning consistency and have a black, powder-coated steel insert ring that delivers desired effect when pedaled, and affords additional support once the head is under tension. It will perform magnificently at *ppp* with soft mallets, yet will not break up or sound harsh at *fff*. Through all this, it retains definite pitch.

(single-ply, 7.5mil)

Item #	Diameter	Retail
ET20	20"	\$196.60
ET20625	20-5/8"	\$196.60
ET21	21"	\$196.60
ET22	22"	\$201.60
ET2250	22-1/2"	\$201.60
ET23	23"	\$201.60
ET2350	23-1/2"	\$201.60
ET24	24"	\$201.60
ET2425	24-1/4"	\$201.60
ET2450	24-1/2"	\$208.25
ET25	25"	\$208.25
ET2550	25-1/2"	\$208.25
ET26	26"	\$208.25
ET2650	26-1/2"	\$214.90
ET27	27"	\$214.90
ET2750	27-1/2"	\$214.90

(single-ply, 7.5mil)

Item #	Diameter	Retail
ET2775	27-3/4"	\$214.90
ET28	28"	\$214.90
ET2850	28-1/2"	\$221.05
ET29	29"	\$221.05
ET30	30"	\$221.05
ET3050	30-1/2"	\$221.05
ET31	31"	\$221.05
ET3150	31-1/2"	\$229.90
ET32	32"	\$229.90
ET33	33"	\$229.90
ET3350	33-1/2"	\$237.70
ET34	34"	\$237.70
ET3450	34-1/2"	\$237.70
ET3475	34-3/4"	\$249.35
ET35	35"	\$249.35
ET36	36"	\$249.35

Strata™ Timpani Heads

Strata Timpani heads feature a lightly-textured, calfskin-colored coating to provide warm tone, clarity of pitch, and articulation that blends naturally with the ensemble. Strata Timpani heads are pre-tensioned with a black, powder-coated insert ring for tuning consistency and additional hoop support.

Coated (single-ply, 7.5mil)

Item #	Diameter	Retail
EST20	20"	\$211.85
EST20625	20-5/8"	\$211.85
EST21	21"	\$211.85
EST22	22"	\$217.15
EST2250	22-1/2"	\$217.15
EST23	23"	\$217.15
EST2350	23-1/2"	\$217.15
EST24	24"	\$217.15
EST2425	24-1/4"	\$227.95
EST2450	24-1/2"	\$234.65
EST25	25"	\$234.65
EST2550	25-1/2"	\$234.65
EST26	26"	\$234.65
EST2650	26-1/2"	\$240.75
EST27	27"	\$240.75
EST2750	27-1/2"	\$240.75

Coated (single-ply, 7.5mil)

Item #	Diameter	Retail
EST2775	27-3/4"	\$240.75
EST28	28"	\$240.75
EST2850	28-1/2"	\$245.75
EST29	29"	\$252.15
EST30	30"	\$252.15
EST3050	30-1/2"	\$252.15
EST31	31"	\$258.80
EST3150	31-1/2"	\$258.80
EST32	32"	\$263.80
EST33	33"	\$265.20
EST3350	33-1/2"	\$271.55
EST34	34"	\$271.55
EST3450	34-1/2"	\$272.10
EST3475	34-3/4"	\$272.10
EST35	35"	\$290.70
EST36	36"	\$264.05



No matter the setting or venue or style, these heads have the durability, great clarity, excellent tone, and resonant projection for all situations.

**Jerry Noble,
Wright State University**



I'm excited about the future of Evans products. Those who are purchasing from Evans can be confident they are getting the top of the line.

**Chip Ross,
Eastman School of Music**

TIMPANI HEAD REFERENCE CHART

Manufacturer	Bowl inches	Size cm	Evans Item #
Adams (Philharmonic, Philharmonic Dresden Classic*)	20*	50.8*	23
	23*	58.4*	2550
	25	63.5	2750
	26*	66.0*	2850
	28	71.1	3050
	29*	73.7*	32
	30	76.2	33
32*	81.3*	3475	
Adams (Symphonic, Professional, & Universal)	20	50.8	22
	23	58.4	25
	26	66.0	28
	29	73.7	31
	32	81.3	34
Aehnelt (Munich & Dresden) *Dresden Only	21.5	54.7	24
	22	55.9	25
	23	58.4	26
	25	63.5	2775
	26	66.0	28
	26.5*	67.3*	2850
	28	71.1	31
	29	73.7	32
	31	78.7	3350
	32	81.3	3450
American Drum (Continental & Dresden) *Dresden Only	19	48.2	22
	20	50.8	23
	21.5	54.7	24
	22	55.9	25
	23	58.4	26
	24	60.9	27
	25	63.5	28
	26	66.0	29
	27	68.6	30
	28	71.1	31
	29	73.7	32
	29*	73.7*	3150
	30	76.2	33
31	78.7	34	
31*	78.7*	33	
32	81.3	35	
33	83.8	36	
Dynasty (Grand Professional)	20	50.8	22
	23	58.4	25
	26	66.0	28
	29	73.7	31
	32	81.3	34
	Goodman (Chain)	18	45.7
20		50.8	22
22		55.9	24
23		58.4	25
24		60.9	26
25		63.5	27
26		66.0	28
27		68.6	29
28		71.1	30
29		73.7	31
Goodman (Dresden) *Early Dresden Models	23	58.4	2550
	23*	58.4*	25
	25	63.5	2775
	25*	63.5*	28
	27*	68.6*	3050
	28	71.1	31
GP Percussion (Standard & Baroque) *Baroque	20	50.8	23
	22*	55.9*	2350
	24	60.0	2650
	24*	60.9*	2550
	26	66.0	2850
	29	73.7	3150
32	81.3	35	

When choosing Evans Timpani Heads, substitute a prefix within the blank space to denote the model: 'ET' - Evans Orchestral Timpani Head (opaque) 'EST' - Evans Strata™ Timpani Head (calfskin-colored)

Manufacturer	Bowl inches	Size cm	Evans Item #
Hinger (Dresden or Cable)	20	50.8	23
	22	55.9	25
	23	58.4	26
	25	63.5	28
	28	71.1	31
	31	78.7	34
	32*	81.3	3475
Jenco (Dresden or Rotary)	23	58.4	2650
	25	63.5	2750
	26	66.0	2750
	29	73.7	3050
	30	76.2	33
Kolberg	22	55.9	2350
	24	60.9	26
	26	66.0	28
	29	73.7	31
	31	78.7	33
Lefima (Dresden)	22	55.9	25
	23	58.4	26
	25	63.5	27
	26	66.0	28
	26	66.0	2850
	28	71.1	31
Lefima (Voyager I & II)	30	76.2	33
	22	55.9	2425
	25	63.5	2650
	26	66.0	2775
	28	71.1	30
Lefima (Light)	31	78.7	30
	21.5	54.6	23
	23	58.4	25
	24	60.9	26
	26	66.0	2775
Walter Light (After 1986)	28	71.1	30
	16	40.6	19
	18	45.7	21
	20	50.8	23
	21.5	54.7	24
	23	58.4	26
	24	60.9	27
	25	63.5	28
	26	66.0	2850
	28	71.1	31
	29	73.7	3150
	31	78.7	34
	32	81.3	35
33	83.8	36	
34	86.3	37	
Ludwig & Ludwig Leedy & Ludwig W.F.L. Ludwig Slingerland *Pre 1978 sizes	20	50.8	20625
	23	58.4	2425
	24*	60.9*	25
	25*	63.5*	26
	26	66.0	27
	27*	68.6*	28
	28*	71.1*	29
	29	73.7	30
	30*	76.2*	31
	Ludwig Ringer/Rogers (Double Suspension Bowl) (Grand Symphonic, Professional, Standard, Universal)	20	50.8
23		58.4	25
26		66.0	28
29		73.7	31
32		81.3	34

Manufacturer	Bowl inches	Size cm	Evans Item #
Majestic (Symphony Grand, Symphonic, Harmonic Series)	20	50.8	22
	23	58.4	25
	26	66.0	28
	29	73.7	31
	32	81.3	34
New Yorker (Dresden & Chain) *Formerly Goodman	20	50.8	23
	22	55.9	25
	23	58.4	26
	24	60.9	27
	25	63.5	28
	26	66.0	29
	27	68.6	30
	28	71.1	31
	29	73.7	32
	30	76.2	33
Ohio Timpani *Formerly Clevelandler	31	78.7	34
	20	50.8	23
	24	60.9	26
	26	66.0	2850
	29	73.7	3150
Premier (Pro Symphonic Concert Copper)	30	76.2	31
	32	81.3	33
	22.5	55.9	2350
	25	63.5	26
	28	71.1	29
Premier (Elite)	30	76.2	33
	32	81.3	35
	22.5	55.9	2550
	25	63.5	28
	28	71.1	31
Gunter Ringer (German Model, Berlin)	30	76.2	32
	20	50.8	2250
	23	58.5	25
	25	63.5	2750
	28	71.1	3050
Stotz (Cable)	30	76.2	32
	20	50.8	23
	22	55.9	25
	23	58.4	26
	24	60.9	27
	25	63.5	28
	26	66.0	29
	27	68.6	30
	28	71.1	31
	29	73.7	32
	30	76.2	33
	31	78.7	34
	32	81.3	35
Yamaha (3000, 4100 & 4200)	23	58.4	25
	26	66.0	28
	29	73.7	31
	32	81.3	34
	Yamaha (6100, 6200)	20	50.8
23		58.4	25
26		66.0	28
29		73.7	31
32		81.3	34
Yamaha (7100, 7200*)		20	50.8
	23*	58.4	25
	24	60.9	26
	26*	66.0*	28
	27	68.6	29
	29*	73.7*	31
Yamaha (7100, 7200*)	32*	81.3*	34
	20	50.8	22
	23	58.4	25
	26	66.0	28
	29	73.7	31
32	81.3	34	

DRUM KEYS

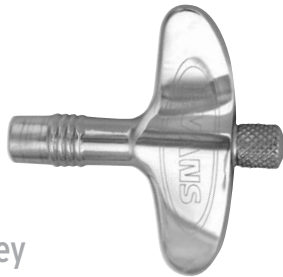

Magnetic Head Drum Key

(an NS Design product)

This drop-forged drum key is ergonomically designed for comfort and has a knurled knob for quick, easy spinning. Its magnetic head helps prevent slipping and stays in place for fast tightening and loosening. The rattle-free design grips tight to a tension rod during play so it won't buzz.

Item #	Retail
DADK	\$20.70



Torque Key

(an NS Design product)

The Evans Torque Key has an ergonomic grip for maximum comfort, a knurled knob for quick spinning, and a slip-resistant magnetized head. The torque handle can be set to a desired tension to help drummers attain more accurate tuning. Not recommended for use with drum hardware.

Item #	Retail
DATK	\$49.80



Drill Bit Key

(an NS Design product)

This drop-forged drill bit key is rattle-free and designed to fit most variable speed cordless drills and screwdrivers.

Item #	Retail
DABK	\$12.10

BASS DRUM PATCHES

AF Patch™

Made of aramid fiber, the AF Patch provides unsurpassed durability and emphasizes attack characteristics. Four radial slits along the perimeter allow the head to vibrate naturally for better tone and feel.



Item #	Retail
EQPAF1 (2)	\$17.25

EQ Bass Drum Patches

Black Nylon

This non-slip, flexible nylon bass drum patch softens attack and strengthens the head without affecting sound quality.

Item #	Retail
EQPB1 Single Pedal (2)	\$11.60
EQPB2 Double Pedal (2)	\$11.60

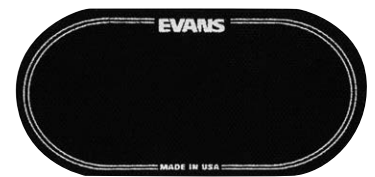

Clear Plastic

This clear, non-slip plastic bass drum patch increases attack and strengthens the head without affecting sound quality.

Item #	Retail
EQPC1 Single Pedal (2)	\$11.60
EQPC2 Double Pedal (2)	\$11.60



PERCUSSION ACCESSORIES

SOUND CONTROL

E-Rings™

The E-Ring is an easy-to-use external overtone control ring which “floats” on the surface of a drumhead. It removes overtones and flattens the drumhead’s sound and allows for easier tuning. Our E-Ring PrePaks™ are designed to match the most common drum set configurations, and allow dealers to stock a minimal number of SKUs in order to meet the needs of customers.

PrePaks

Item #	Diameter	Retail
ER-STANDARD	12", 13", 14", 16"	\$21.45
ER-FUSION	10", 12", 14" (2)	\$18.25
ER-SNARE	14 x 1" - 14 x 1.5"	\$16.25



Filler Packs (10 Packs)

Item #	Diameter	Width	Retail
E10ER1	10"	1"	\$49.80
E12ER15	12"	1.5"	\$49.80
E13ER15	13"	1.5"	\$49.80
E14ER1	14"	1"	\$49.80
E14ER15	14"	1.5"	\$49.80
E14ER2	14"	2"	\$49.80
E15ER2	15"	2"	\$49.80
E16ER2	16"	2"	\$49.80
E18ER2	18"	2"	\$49.80

EQ Pad™

The EQ Pad is a highly efficient bass drum muffler that attaches to the bottom of the bass drum shell with Velcro®. The hinged pad bounces off the head, allowing sustain before damping the vibrating head. The new version includes a smaller pad on the opposite end that can be used on smaller drums or for minimal damping.



Item #	Retail
EQPAD	\$39.95



No matter what heads they use, for over 20 years I always use the EQ Pad in our kick drum.

**Timmy Doyle,
Drum Tech
Smashing Pumpkins,
Guns N' Roses**



Min-EMAD™

Trim and unobtrusive, the Min-EMAD removes unwanted frequencies but retains desired attack, tone, and feel. By linking the vibrating head with the relatively inert counterhoop, the Min-EMAD removes overtones by resisting the motion of the head.

Item #	Description	Retail
MINEMAD	6-Pack	\$12.10

MARCHING ACCESSORIES



Control Screen

Designed for marching snare drums and used by top marching groups, the Evans Control Screen offers a simple and effective way to reduce overall volume without sacrificing tone, articulation, or feel. Fitting neatly underneath the drumhead, the Evans Control Screen is simple to install and remove as needed. The Evans Control Screen is available in 13" and 14".

Item #	Diameter	Retail
EMA13CS1	13"	\$24.90
EMA14CS1	14"	\$24.90



Custom Pro Series

The Custom Pro Series of snare wires are the ultimate in ease-of-use. They're designed with Anti-Choke™ end plates that significantly reduce annoying snare buzz, and also allow the player to crank up their snare tension for a tight response without choking the drum. The Speed Release™ straps allow the player to disengage the snare wires without releasing the straps from the strainer or butt clamps, enabling quick and easy head or wire changes.

Steel

Item #	Description	Retail
CPS1320	13" Steel - 20 Strand	\$44.95
CPS1324	13" Steel - 24 Strand	\$44.95
CPS1420	14" Steel - 20 Strand	\$44.95
CPS1424	14" Steel - 24 Strand	\$44.95

Brass

Item #	Description	Retail
CPB1320	13" Brass - 20 Strand	\$44.95
CPB1324	13" Brass - 24 Strand	\$44.95
CPB1420	14" Brass - 20 Strand	\$44.95
CPB1424	14" Brass - 24 Strand	\$44.95

AS EASY AS ...

- 1 Speed Release™ Strap** for quick wire or head changes
- 2 Anti-Choke™ End Plates** reduce sympathetic snare buzz & increase wire tension range
- 3 Alignment Marks** for straight and repeatable wire position

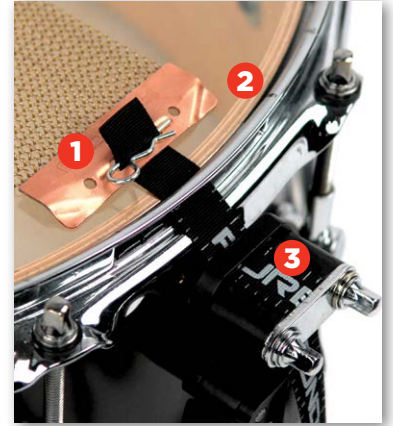

Custom Pros really bring the snare out of my snare drum AND it's hard to believe how easy it is to change them!

Charlie Benante, Anthrax

Custom Series

Custom Series wires feature medium-gauge wire with evenly spaced, standard coils. The Custom line offers 4 different strand configurations that can be employed to change the balance between the drum and snare components of the sound. Models with more strands tend to allow the snares to be more active in influencing the sound, while those with less strands allow the drum to be more prominent in the overall drum sound.

Item #	Description	Retail
P0812	8" - 12 strand	\$39.05
P1016	10" - 16 strand	\$39.05
P1216	12" - 16 strand	\$39.05
P1220	12" - 20 strand	\$39.05
P1316	13" - 16 strand	\$39.05
P1320	13" - 20 strand	\$39.05
P1324	13" - 24 strand	\$39.05
P1416	14" - 16 strand	\$39.05
P1420	14" - 20 strand	\$39.05
P1424	14" - 24 strand	\$39.05
P1520	15" - 20 strand	\$39.05

Equalizer Series

The Equalizer line has been created to modify the spread and activity of the snare sound by working in conjunction with the snare drum's natural acoustics and snare bed design. Equalizers feature an offset design that removes the strands from the middle of the drum, decreasing the vibration of the wires. Not only is the snare drum drier and crisper with an Equalizer, it is less influenced by sympathetic vibrations from other drums and instruments.

Item #	Description	Retail
E1312	13" - 12 strand	\$39.05
E1316	13" - 16 strand	\$39.05
E1412	14" - 12 strand	\$39.05
E1416	14" - 16 strand	\$39.05



PURESOUND SNARE WIRES

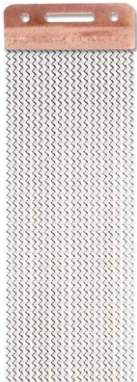

Blaster Series

Blasters Series snare wires are professional-quality snares developed for high-volume, high-intensity drumming. They feature specially formulated, premium-grade steel alloy wires on angled, copper-colored end clips. The exclusive bent end clips create greater snare wire contact across the entire surface of the drumhead, offering increased activity, consistency, response and projection.

Item #	Description	Retail
B1016	10" - 16 strand	\$39.05
B1220	12" - 20 strand	\$39.05
B1320	13" - 20 strand	\$39.05
B1420	14" - 20 strand	\$39.05



Concert Series

The Concert Series wires have been developed specifically for use on concert and orchestral snare drums, and are made from a specially formulated stainless steel alloy combined with an extended coil pattern to create a deeper, drier, and darker tone with increased articulation.

Item #	Description	Retail
C1412	14" - 12 strand	\$39.05
C1416	14" - 16 strand	\$39.05

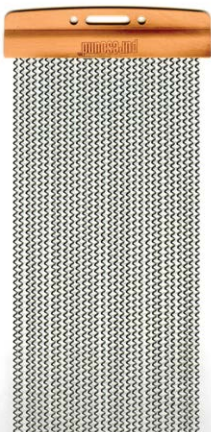

Super 30 Series

The Super 30 Series utilizes the same steel alloy wires, handcrafted construction methods, and exclusive copper end clips as the Custom Series in a 30-strand format designed to increase snare response and articulation. Compared to other wide-format snare wires, the Puresound Super 30 wires are able to create a distinctive and penetrating sound without choking the drum or sacrificing its feel. Additionally, the Super 30 needs only a slightly wider than normal snare bed (3-3.5 inch) for optimum performance.

Item #	Description	Retail
S1230	12"	\$51.80
S1330	13"	\$51.80
S1430	14"	\$51.80

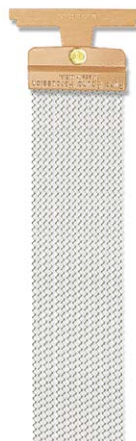

Vintage Series

The Vintage Series snare wires are designed not only to replace worn and no longer available wires on vintage snare drums, but they are also designed to enhance the performance of those classic drums. With a new set of Puresound wires, Dynasonics, Radio Kings, and Super Sensitives will sound and perform as well as, if not better, than they did when they were new.

Item #	Description	Retail
PD1416	14" Dynasonic	\$77.50
PF1416	14" Pearl Free-Floating	\$77.50
PR1416	14" Radio King Clam Shell	\$77.50
PS1412	14" Super Sensitive (1920-1968)	\$77.50
PS1416	14" Super Sensitive (1969-Present)	\$77.50

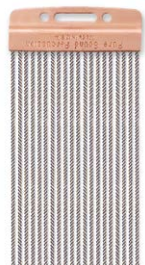

Twisted Series

The Twisted Series are made from twenty double strands of Puresound's premium-grade steel alloy wire that are braided together, resulting in increased levels of dryness, articulation, and response.

Item #	Description	Retail
T1320	13" - 20 Double Strand	\$64.50
T1420	14" - 20 Double Strand	\$64.50

SNARE ACCESSORIES



Item #	Description	Retail
MC4	Blue Cable Strings (4pcs)	\$15.40
MC50	50 ft. Spool Blue Cable String	\$64.50
MS4	Black Nylon Strings (4pcs)	\$13.90
MS50	50 ft. Spool Black Nylon String	\$64.50
MT4	Mylar Straps (4pcs)	\$13.90



RealFeel™ Practice Pads

RealFeel Practice Pads are the most popular practice option available. Featuring a natural gum rubber playing surface with a dark gray fabric finish which resists wear and tear, RealFeel practice pads provide the best practice substitute to an acoustic drum. A variety of models are available to suit individual practice requirements. RealFeel practice pads come in self-display cases for easy merchandising.

Item #	Description	Special Features	Retail
RF6GM	6" Mountable Speed Pad	Single-sided gum rubber surface with an 8mm threaded insert	\$40.25
RF12G	12" Speed Pad	Single-sided gum rubber surface	\$64.50
RF6D	6" Speed & Workout Pad	Two-sided pad with gum rubber and neoprene surfaces	\$44.95
RF12D	12" Speed & Workout Pad	Two-sided pad with gum rubber and neoprene surfaces	\$77.50

Apprentice™ Beginner Practice Pads

Item #	Description	Special Features	Retail
ARF7GM	7" Apprentice Pad	Single-sided gum rubber pad with an 8mm thread for mounting	\$39.95



RealFeel™ Folding Bass Pedal Practice Pad

The sturdy, lightweight, and collapsible construction of the RealFeel™ Folding Bass Pedal Practice Pad makes it the perfect footwork practice tool for the gigging drummer, student, or hobbyist. The impact pad is wide enough to accommodate a double-pedal, and offers a realistic rebound that mimics the action of a drumhead.

Item #	Retail
RFBASS	\$140.85



I have traveled to over 60 countries sharing the joy of drumming and my RealFeel Pad is always with me.

Dom Famularo

Apprentice Pad Stand

The Apprentice Pad Stand is a compact, lightweight, and single-braced stand with an 8mm threaded post and pivoting platform for attaching the 7" Apprentice Pad and the 6" RealFeel Mountable Speed Pad. The height is adjustable, and the post can be tilted to any angle to suit the player's preference.

Item #	Retail
ARFSTD	\$85.20



DRUM SET MUTES



S014HAT

S020RIDE & S022RIDE

SoundOff™ Drum Mutes

SoundOff Drum Mutes are the most popular line of volume control products available. The mutes provide significant volume reduction to keep practice noise to a minimum. SoundOff drum mutes feature a durable construction that can withstand frequent practicing. The Bass Mute fits drum sizes 18" to 26" with ease, while the fitted cymbal mutes provide a more realistic rebound on ride and hi-hat cymbals. Assorted drum mute sets are great add-on sales for entry-level drum sets.

Single Mutes

Item #	Description	Retail
S0-6	6" Tom Mute	\$11.55
S0-8	8" Tom Mute	\$12.70
S0-10	10" Tom Mute	\$13.90
S0-12	12" Tom Mute	\$15.40
S0-13	13" Tom Mute	\$17.15
S0-14	14" Tom Mute	\$18.35
S0-15	15" Tom Mute	\$20.70
S0-16	16" Tom Mute	\$23.10
SOBASS	Bass Mute	\$85.20
SO-CYM	Cymbal Mute	\$13.90
S014HAT	14" Hi-Hat Mute	\$27.20
S020RIDE	20" Ride Mute	\$39.05
S022RIDE	22" Ride Mute	\$42.60

Assortments

Item #	Description	Retail
S0-0244	Drum Mute Fusion Pack – 10", 12", 14", 14"	\$55.35
S0-2346	Drum Mute Standard Pack – 12", 13", 14", 16"	\$62.15
SOSETFSN	Box Set – Fusion Includes Cymbal and Bass Mutes 10", 12", 14", 14"	\$200.60
SOSETSTD	Box Set – Standard Includes Cymbal and Bass Mutes 12", 13", 14", 16"	\$206.80



SOBASS

SOSETFSN
SOSETSTD



S0-0244
S0-2346



Practice Pad Displays and Assortments (or create your own mix)

Display Components

Item #	Description	Small Display Parts Quantity	Large Display Parts Quantity
EVUMS1	Modular UMS - Main	1	2
EVUMS2	Modular UMS - End Cap	1	1
EVUMS-SIGNKIT	Signage Kit	1	1

Suggested Display Assortments

Item #	Description	Small Display (HQUMSSM)	Large Display (HQUMSLG)
RealFeel™ Practice Pads			
RF6GM	6" Mountable Speed Pad	10	10
RF12D	12" Speed & Workout Pad	5	5
RFBASS	RealFeel Folding Bass Pad	2	5
ARF7GM	Apprentice Pad	5	10
ARFSTD	Apprentice Pad Stand	2	3
SoundOff™ Drum Mutes			
SO2ORIDE	20" Ride Mute		5
SO14HAT	14" Hi-Hat Mute		5
SO-CYM	Crash Mute (16" - 20")		10
SOBASS	Bass Mute		3
SOSETFSN	Fusion Box Set	3	3
SOSETSTD	Standard Box Set	3	3



Accessories Display and Assortments (shown with small Practice Pad assortment)

Accessories Display Components

Item #	Description	Display Parts Qty
EVUMS1	Modular UMS - Main	1
EVUMS2	Modular UMS - End Cap	1
EVUMS-SIGNKIT	Signage Kit	1

Suggested Accessories Display Assortment

Item #	Description	Assortment Qty (EVUMSACC1)
EQPAD	EQ Pad	3
DADK	Magnetic Head Drum Key	5
DATK	Torque Key	5
EQPAF1	AF Patch	10
EQPB1	EQ Patch - Nylon Single Pedal	10
P1420	14" Custom Series Snare - 20 Strand	5
E1416	14" Equalizer Series Snare - 16 Strand	5
CPS1420	14" Custom Pro Series - 20 Strand Steel	5
CPB1420	14" Custom Pro Series - 20 Strand Brass	5
ER-SNARE	E-Ring Snare Pack	10

Snare Heads

Item #	Size	Description	55pc. Display	110pc. Display	165pc. Display
B14G12	14"	G12 Coated			2
B14G1RD	14"	Power Center Reverse Dot	2	2	4
B14ECSR	14"	EC Reverse Dot		2	4
B14EC1RD	14"	EC1 Reverse Dot		2	4
B14HW	14"	Heavyweight	2	4	4
B14GEN	14"	Genera			4
B14DRY	14"	Genera Dry	2	4	4
B14HD	14"	Genera HD			4
B14HDD	14"	Genera HD Dry	2	4	6
B14STD	14"	ST Dry			4
S14H30	14"	Snare Side 300	2	2	4
TT14C7	14"	Calftone		2	2

Bass Heads

Item #	Size	Description	55pc. Display	110pc. Display	165pc. Display
BD22EMAD	22"	EMAD Batter Clear	2	3	4
BD22GMAD	22"	GMAD Batter Clear		2	2
BD22EMAD2	22"	EMAD2 Batter Clear	2	3	6
BD22EMADHW	22"	EMAD Heavyweight Batter Clear	1	2	4
BD22GB3	22"	EQ3 Batter Clear	1	2	2
BD22GB4	22"	EQ4 Batter Clear	1	2	2
BD22REMAD	22"	EMAD Resonant Black	1	2	2
BD22RB	22"	EQ3 Resonant Black	1	2	2
BD22RONX	22"	ONYX Resonant		1	2
BD22GB4CT	22"	EQ4 Calftone		1	1
BD22EMADCT	22"	EMAD Calftone			1

Tom Heads

Item #	Size	Description	55pc. Display	110pc. Display	165pc. Display
TT08G1	8"	G1 Clear			1
TT10G1	10"	G1 Clear		1	1
TT12G1	12"	G1 Clear		1	1
TT13G1	13"	G1 Clear		1	1
TT14G1	14"	G1 Clear		1	1
TT16G1	16"	G1 Clear		1	1
B08G1	8"	G1 Coated			1
B10G1	10"	G1 Coated		2	2
B12G1	12"	G1 Coated		3	3
B13G1	13"	G1 Coated		1	1
B14G1	14"	G1 Coated		2	2
B16G1	16"	G1 Coated		2	2
B10UV1	10"	UV1 Coated	2	2	2
B12UV1	12"	UV1 Coated	2	2	3
B13UV1	13"	UV1 Coated	1	1	3
B14UV1	14"	UV1 Coated	2	2	4
B16UV1	16"	UV1 Coated	2	2	2
TT08G2	8"	G2 Clear			1
TT10G2	10"	G2 Clear	2	2	2
TT12G2	12"	G2 Clear	2	3	3
TT13G2	13"	G2 Clear	1	1	1
TT14G2	14"	G2 Clear	2	2	2
TT16G2	16"	G2 Clear	2	1	2
B08G2	8"	G2 Coated			1
B10G2	10"	G2 Coated	2	2	2
B12G2	12"	G2 Coated	2	3	3
B13G2	13"	G2 Coated	1	1	1
B14G2	14"	G2 Coated	2	2	3
B16G2	16"	G2 Coated	2	1	3
TT08CHR	8"	Black Chrome			1
TT10CHR	10"	Black Chrome		2	2
TT12CHR	12"	Black Chrome		2	3
TT13CHR	13"	Black Chrome		1	1
TT14CHR	14"	Black Chrome		2	2
TT16CHR	16"	Black Chrome		2	2
TT08EC2S	8"	EC2 Clear			1
TT10EC2S	10"	EC2 Clear	2	2	2
TT12EC2S	12"	EC2 Clear	2	3	3
TT13EC2S	13"	EC2 Clear	1	1	1
TT14EC2S	14"	EC2 Clear	2	2	3
TT16EC2S	16"	EC2 Clear	2	2	3
TT10HG	10"	Hydraulic Glass		1	2
TT12HG	12"	Hydraulic Glass		2	3
TT13HG	13"	Hydraulic Glass		1	1
TT14HG	14"	Hydraulic Glass		2	3
TT16HG	16"	Hydraulic Glass		1	3



PROMARK SETS FIRE TO THE STATUS QUO

In 2017, Promark by D'Addario turned up the heat and set fire to the industry with the launch of its most durable line of hickory drumsticks to date — **FireGrain™**. At its sawmill in the heart of the Appalachian region in Tennessee, D'Addario's in-house engineering team patented a revolutionary flame tempering process that transforms ordinary hickory drumsticks into precision tools with unprecedented durability. Combined with our advanced sorting technique that selects only the most premium hickory dowels, FireGrain reduces stick pair variation to an indiscernible 6 grams, making it the most durable and consistent hickory drumstick line in the industry.



To continue the success of Promark's **ActiveGrip™** series, our heat-activated drumstick coating has extended its line to include the evergreen **Classic 7A, 5A, and 5B** models. This technology is also available on the new **Stephen Creighton Pipe Band Signature Stick**, replacing the need for stick wrap as a much-needed solution to the community-wide problem. Now pipe band drummers all over the world have more products that are **Built To Compete** and stand up to the rigorous demands of modern, championship winning corps like Stephen Creighton and St. Laurence O'Toole.

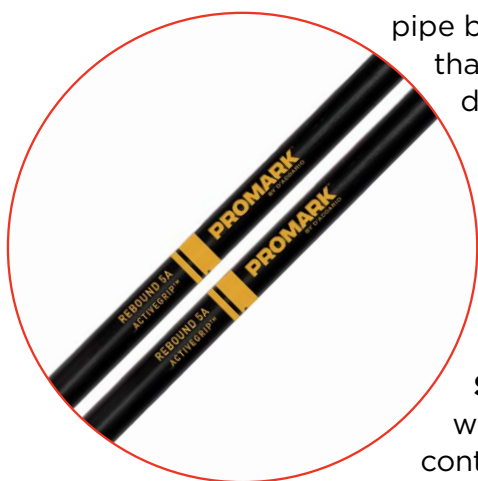

Developed with artist, educator and Houston Symphony percussionist Matthew Strauss, our new and highly acclaimed concert percussion implements propel the aspiring percussionist and symphony professional further than ever before. The **Matthew Strauss Concert General** drumstick redefines versatility with a unique, elongated tip shape for unprecedented control and full-bodied tone at all dynamic levels, while the **Staccato** model is the only concert implement that utilizes a nylon-injected tip, creating a bright tone and rhythmic clarity at soft dynamics.

Looking forward to 2018, Promark has reimagined their entire mallet manufacturing process. Shelving outdated practices like nailing cores to shafts and faulty winding procedures, our in-house engineering team leveraged D'Addario's string winding expertise and injection molding capabilities while implementing aerospace methodology to redefine durability, playability, and consistency for mallet percussionists. Stay tuned to learn more about the new **SPYR** line of Promark mallets, and see why players across the globe are clamoring to get their hands on a pair.

TOP SELLERS & MUST HAVES



FIREGRAIN
Classic, Rebound,
and Forward Balance
See pages 136-138

**ACTIVEGRIP
SIGNATURE**
Rebound and
Forward Balance
See pages 136-138



**AMERICAN
HICKORY**
Rebound and
Forward Balance
See pages 136-138

**AMERICAN
HICKORY**
Classic
See pages 136-138



**SHIRA
KASHI
OAK**
See pages 142-144

**AMERICAN
HICKORY**
Natural
See pages 136-139



**AMERICAN
MAPLE**
See page 145

**AMERICAN
HICKORY**
Long
See pages 136 & 137



**ALTERNATIVE
SOUND SOURCES**
See page 147

**MARCHING
DRUMSTICKS &
MALLETS**
See page 151-155



**BAND & ORCHESTRA
DRUMSTICKS &
MALLETS**
See page 157















ACCESSORIES
See pages 149-150 & 162











DRUM SET DRUMSTICKS

PROMARK AMERICAN HICKORY

Because of its resilience, responsiveness, and durability, hickory is the most commonly used wood for the classic drumstick feel. Promark's American Hickory drumsticks are available with wood tips, nylon tips, lacquer finish, natural finish, as well as our patented ActiveGrip and FireGrain technologies.

7A		Description	Item #	Tip	Diameter	Length	Taper	Retail
MUST★HAVE		Forward 7A	FBH535AW	Acorn	.535"	16"	Forward 2 1/4"	\$19.30
MUST★HAVE		Rebound 7A	RBH535AW	Acorn	.535"	16"	Rebound 3"	\$19.30
MUST★HAVE		Forward 7A ActiveGrip	F7AAG	Acorn	.535"	16"	Forward 2 1/4"	\$21.80
MUST★HAVE		Rebound 7A ActiveGrip	R7AAG	Acorn	.535"	16"	Rebound 3"	\$21.80
		Forward 7A	FBH535TW	Teardrop	.535"	16"	Forward 2 1/4"	\$19.30
		Rebound 7A	RBH535TW	Teardrop	.535"	16"	Rebound 3"	\$19.30
MUST★HAVE		Classic 7A	TX7AW	Oval	.512"	15 3/8"	2 3/4"	\$19.30
NEW!	MUST★HAVE 	Classic 7A ActiveGrip	TX7AW-AG	Oval	.512"	15 3/8"	1 1/2"	\$21.80
NEW!	MUST★HAVE 	Classic 7A FireGrain	TX7AW-FG	Oval	.512"	15 3/8"	1 1/2"	\$24.95
		Classic 7A Nylon	TX7AN	Oval	.512"	15 3/8"	1 1/2"	\$19.85
		Classic Natural 7A	TXR7AW	Oval	.512"	15 3/8"	1 1/2"	\$19.30
		Classic Natural 7A Nylon	TXR7AN	Oval	.512"	15 3/8"	1 1/2"	\$19.85
		Classic Pro-Round 7A	TXPR7AW	Small Round	.512"	15 3/8"	1 1/2"	\$19.30
		Classic Jazz Nylon	TXJZN	Oval	.512"	16"	1 3/4"	\$19.85
		Junior	TXJRW	Oval	.531"	13"	3 1/2"	\$18.50

5A		Description	Item #	Tip	Diameter	Length	Taper	Retail
MUST★HAVE		Forward 5A	FBH565AW	Acorn	.565"	16"	Forward 2 1/4"	\$19.30
MUST★HAVE		Rebound 5A	RBH565AW	Acorn	.565"	16"	Rebound 3"	\$19.30
MUST★HAVE		Forward 5A ActiveGrip	F5AAG	Acorn	.565"	16"	Forward 2 1/4"	\$21.80
MUST★HAVE		Rebound 5A ActiveGrip	R5AAG	Acorn	.565"	16"	Rebound 3"	\$21.80
NEW!	MUST★HAVE 	Rebound 5A FireGrain	R5AFG	Acorn	.565"	16"	Rebound 3"	\$24.95
NEW!	MUST★HAVE 	Forward 5A FireGrain	F5AFG	Acorn	.565"	16"	Forward 2 1/4"	\$24.95
		Forward 5A	FBH550TW	Teardrop	.550"	16"	Forward 2 1/4"	\$19.30
		Rebound 5A	RBH550TW	Teardrop	.550"	16"	Rebound 3"	\$19.30

DRUM SET DRUMSTICKS

5A (continued)

	Description	Item #	Tip	Diameter	Length	Taper	Retail
MUST★HAVE	Classic 5A	TX5AW	Oval	.551"	16"	1 7/8"	\$19.30
NEW!	Classic 5A ActiveGrip	TX5AW-AG	Oval	.551"	16"	1 7/8"	\$21.80
NEW!	Classic 5A FireGrain	TX5AW-FG	Oval	.551"	16"	1 7/8"	\$24.95
MUST★HAVE	Classic 5A Nylon	TX5AN	Oval	.551"	16"	1 7/8"	\$19.85
MUST★HAVE	Classic Natural 5A	TXR5AW	Oval	.551"	16"	1 7/8"	\$19.30
	Classic Natural 5A Nylon	TXR5AN	Oval	.551"	16"	1 7/8"	\$19.85
	Classic Pro-Round 5A	TXPR5AW	Small Round	.551"	16"	1 7/8"	\$19.30
	Forward 5A	FBH565TW	Teardrop	.565"	16"	Forward 2 1/4"	\$19.30
	Rebound 5A	RBH565TW	Teardrop	.565"	16"	Rebound 3"	\$19.30
	Classic 5AB (5B Tip)	TX5ABW	Oval	.551"	16"	1 1/2"	\$19.30
	Classic 5AB Nylon (5B Tip)	TX5ABN	Oval	.551"	16"	1 1/2"	\$19.85
MUST★HAVE	Classic Rock Knocker	TXRKW	Butt End	.551"	16"	N/A	\$19.30

5A LONG

	Description	Item #	Tip	Diameter	Length	Taper	Retail
MUST★HAVE	Classic 747	TX747W	Oval	.551"	16 1/4"	2 1/2"	\$19.30
MUST★HAVE	Classic 747 Nylon	TX747N	Oval	.551"	16 1/4"	2 1/2"	\$19.85
	Classic 747 Natural	TXR747W	Oval	.551"	16 1/4"	2 1/2"	\$19.30
	Classic 747 Natural Nylon	TXR747N	Oval	.551"	16 1/4"	2 1/2"	\$19.85
	Classic 718 Acid Jazz	TX718W	Small Round	.551"	16 1/4"	3 1/4"	\$19.30
MUST★HAVE	Classic 707 Round Nylon	TX707N	Large Round	.551"	16 1/4"	3 1/2"	\$19.85
	Classic 5A Long	TX5ALW	Oval	.551"	16 1/2"	2 3/4"	\$19.30
NEW!	Rebound 5A Long	RBH565LAW	Acorn	.565"	16 1/2"	3"	\$19.30

55A

	Description	Item #	Tip	Diameter	Length	Taper	Retail
	Forward 55A	FBH580TW	Teardrop	.580"	16"	Forward 2 1/4"	\$19.30
	Rebound 55A	RBH580TW	Teardrop	.580"	16"	Rebound 3"	\$19.30
MUST★HAVE	Future Pro	TXSD1FW	Large Round	.579"	14 3/4"	3 1/8"	\$19.30
	Classic 720 Intruder	TX720W	Acorn	.571"	16 1/2"	3 3/4"	\$19.30

FORWARD = 2 1/4" taper to optimize POWER & SPEED **REBOUND** = 3" taper to optimize FINESSE & AGILITY

DRUM SET DRUMSTICKS

PROMARK AMERICAN HICKORY

5B

	Description	Item #	Tip	Diameter	Length	Taper	Retail
MUST★HAVE	Forward 5B	FBH595AW	Acorn	.595"	16"	Forward 2 1/4"	\$19.30
MUST★HAVE	Rebound 5B	RBH595AW	Acorn	.595"	16"	Rebound 3"	\$19.30
MUST★HAVE	Forward 5B ActiveGrip	F5BAG	Acorn	.595"	16"	Forward 2 1/4"	\$21.80
MUST★HAVE	Rebound 5B ActiveGrip	R5BAG	Acorn	.595"	16"	Rebound 3"	\$21.80
NEW!	Forward 5B FireGrain	F5BFG	Acorn	.595"	16"	Forward 2 1/4"	\$24.95
NEW!	Rebound 5B FireGrain	R5BFG	Acorn	.595"	16"	Rebound 2"	\$24.95
	Forward 5B	FBH595TW	Teardrop	.595"	16"	Forward 2 1/4"	\$19.30
	Rebound 5B	RBH595TW	Teardrop	.595"	16"	Rebound 3"	\$19.30
MUST★HAVE	Classic 5B	TX5BW	Oval	.590"	16"	2"	\$19.30
	Classic 5B ActiveGrip	TX5BW-AG	Oval	.590"	16"	2"	\$21.80
NEW!	Classic 5B FireGrain	TX5BW-FG	Oval	.590"	16"	2"	\$24.95
MUST★HAVE	Classic 5B Nylon	TX5BN	Oval	.590"	16"	2 7/8"	\$19.85
MUST★HAVE	Classic Natural 5B	TXR5BW	Oval	.590"	16"	2"	\$19.30
	Classic Natural 5B Nylon	TXR5BN	Oval	.590"	16"	2"	\$19.85
	Classic Pro-Round 5B	TXPR5BW	Small Round	.590"	16"	2"	\$19.30

5B LONG

	Description	Item #	Tip	Diameter	Length	Taper	Retail
MUST★HAVE	Classic 747 Super Rock	TX747BW	Oval	.590"	16 3/4"	2 3/4"	\$19.30
	Classic 747 Super Rock Nylon	TX747BN	Oval	.590"	16 3/4"	2 3/4"	\$19.85
NEW!	Rebound 5B Long	RBH595LAW	Acorn	.595"	16 1/2"	3"	\$19.30





2B

	Description	Item #	Tip	Diameter	Length	Taper	Retail
MUST★HAVE	Classic 2B	TX2BW	Oval	.630"	16"	2 1/4"	\$19.30
NEW!	Classic 2B FireGrain	TX2BW-FG	Oval	.630"	16"	2 1/4"	\$24.95
MUST★HAVE	Classic 2B Nylon	TX2BN	Oval	.630"	16"	2 1/4"	\$19.85

FORWARD = 2 1/4" taper to optimize POWER & SPEED





REBOUND = 3" taper to optimize FINESSE & AGILITY

2B (continued)

	Description	Item #	Tip	Diameter	Length	Taper	Retail
	Classic Natural 2B	TXR2BW	Oval	.630"	16"	2 1/4"	\$19.30
	Classic Natural 2B Nylon	TXR2BN	Oval	.630"	16"	2 1/4"	\$19.85
	Classic SD1	TXSD1W	Large Round	.630"	16 3/8"	3 5/8"	\$19.30
	Classic 419 Stroker	TX419W	Oval	.630"	16 1/2"	3 1/8"	\$19.30
	Classic 2S	TX2SW	Oval	.630"	17"	2"	\$19.30





PROMARK ARTIST SERIES AMERICAN HICKORY

7A

	Description	Item #	Tip	Diameter	Length	Taper	Retail
 MUST★HAVE	Mike Portnoy 420	TX420N	Oval	.531"	16 1/8"	3 1/4"	\$22.60
	Horacio "El Negro" Hernandez 424	TX424W	Small Round	.500"	16"	2 3/8"	\$21.80
	Elvin Jones Jazz JZ	TXJZW	Oval	.512"	16"	2 3/4"	\$21.80
	Jim Rupp 8A	TX8AW	Teardrop	.530"	15 3/4"	3 1/8"	\$21.80
	Michael Carvin 733	TX733W	Small Round	.531"	16"	3 1/4"	\$21.80

5A



	Description	Item #	Tip	Diameter	Length	Taper	Retail
 MUST★HAVE	Mike Portnoy 420X ActiveGrip	TXMP420XW-AG	Oval	.565"	16 1/4"	3 3/4"	\$24.00
	Chris Adler 5AX	TX5AXW	Acorn	.551"	16"	3 1/2"	\$21.80
	Joey Jordison 515	TX515W	Round	.551"	16"	2 3/4"	\$21.80
	Rick Latham 717	TX717W	Barrel	.551"	16"	3 7/8"	\$21.80
 MUST★HAVE	Simon Phillips 707	TX707W	Round	.551"	16 1/4"	3 1/2"	\$21.80

DRUM SET DRUMSTICKS

PROMARK ARTIST SERIES AMERICAN HICKORY

55A

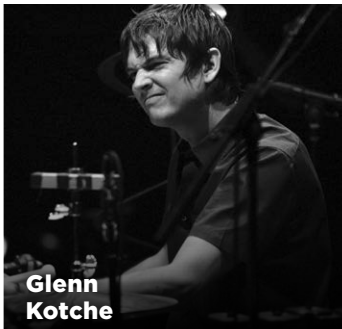

Glenn Kotche

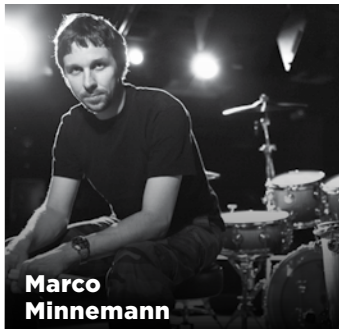

Marco Minnemann



Ian Paice



Steve Ferrone

MUST★HAVE

Glenn Kotche Active Wave 570™ Signature Stick

Designed to meet the requirements of Glenn Kotche from Wilco comes the Active Wave 570. Featuring the all new **ActiveGrip™** – a heat-activated grip coating that gets tackier when a player's hands heat up and start to sweat, and the new **WaveHandle™** – a contoured handle that provides additional grip and a comfortable place for all fingers.

WaveHandle



Description	Item#	Tip	Diameter	Length	Taper	Retail
Glenn Kotche Active Wave 570	TXGKAWW	Acorn	.570"	16 3/4"	3 1/2"	\$25.95
Marco Minnemann 721	TX721W	Barrel	.571"	16"	3 1/8"	\$21.80
Ian Paice 808L	TX808LW	Round	.579"	16 1/8"	4 1/2"	\$21.80
Steve Ferrone 735	TX735W	Acorn	.579"	16 13/16"	3 1/2"	\$21.80
Paul Wertico 808	TX808W	Round	.579"	16"	3 1/4"	\$21.80
Carl Palmer CP	TXCPW	Teardrop	.579"	14 3/4"	3 7/8"	\$21.80
Phil Collins PC	TXPCW	Round	.579"	14 3/4"	3 1/8"	\$21.80
Will Kennedy WK	RBWKW	Teardrop	.580"	16 1/2"	3"	\$21.80

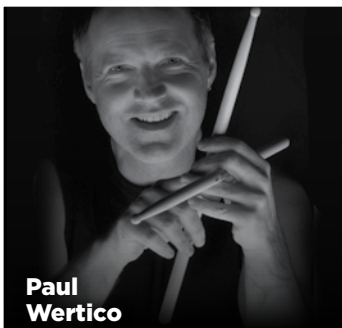

Paul Wertico



Carl Palmer



Phil Collins



Will Kennedy

PROMARK ARTIST SERIES AMERICAN HICKORY



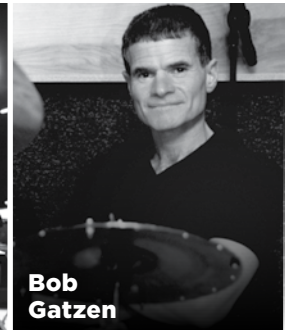
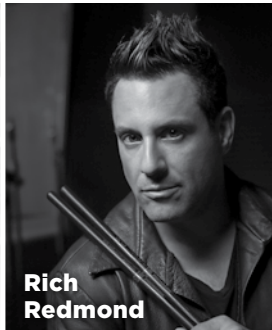
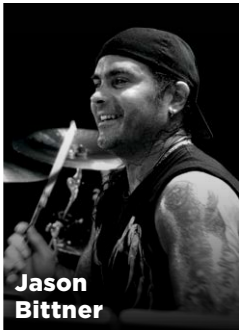

5B

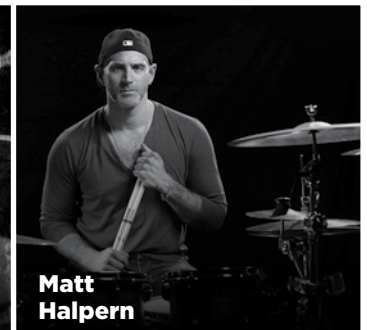

	Description	Item #	Tip	Diameter	Length	Taper	Retail
	Jason Bittner 5BX Nylon	TX5BXN	Oval	.590"	16 1/8"	3 3/4"	\$22.60
	Anton Fig ActiveGrip 595	TXAFW-AG	Large Round	.595"	16 3/4"	3 1/8"	\$24.00
	Rich Redmond ActiveGrip 595	TXRRW-AG	Oval	.595"	16"	2 1/4"	\$24.00
	Marco Minnemann 721B	TX721BW	Barrel	.590"	16"	3 1/8"	\$21.80
	Bob Gatzen Balance Groove	RBBGBGW	Barrel	.585"	16 3/8"	3 3/4"	\$21.80

2B



	Description	Item #	Tip	Diameter	Length	Taper	Retail
	Dave Lombardo 2BX Nylon	TX2BXN	Oval	.630"	16 1/8"	4 1/8"	\$22.60
	Dame Evelyn Glennie 740	TX740W	Barrel	.630"	16 1/8"	4"	\$21.80
	Teddy Campbell SD9	TXSD9W	Oval	.630"	16 1/4"	3 7/8"	\$21.80
	Matt Halpern	TXMHW	Large Round	.630"	16"	3"	\$21.80

DRUM SET DRUMSTICKS

PROMARK SHIRA KASHI OAK

Shira Kashi™ Oak drumsticks offer an unmatched level of power, strength, and durability. Promark was the first company to introduce oak drumsticks in the US, and remains the only drumstick maker to offer Shira Kashi Oak sticks continuously since 1957. Oak is the densest and heaviest of our available wood.



7A

	Description	Item #	Tip	Diameter	Length	Taper	Retail
	Shira Kashi Oak 7A	PW7AW	Oval	.512"	15 3/8"	1 1/2"	\$24.00
	Shira Kashi Oak 7A Nylon	PW7AN	Oval	.512"	15 3/8"	1 1/2"	\$24.80
	Shira Kashi Oak Jazz	PWJZW	Oval	.512"	16"	1 3/4"	\$24.00



7A LONG

	Description	Item #	Tip	Diameter	Length	Taper	Retail
	Shira Kashi Oak 727 Narrow Body Nylon	PW727N	Oval	.531"	16 1/4"	3 1/4"	\$24.80

5A

	Description	Item #	Tip	Diameter	Length	Taper	Retail
	Shira Kashi Oak 5A	PW5AW	Oval	.551"	16"	1 7/8"	\$24.00
	Shira Kashi Oak 5A Nylon	PW5AN	Oval	.551"	16"	1 7/8"	\$24.80
	Shira Kashi Oak Rock Knocker	PWRKW	Butt End	.551"	16"	N/A	\$24.00

5A LONG

	Description	Item #	Tip	Diameter	Length	Taper	Retail
	Shira Kashi Oak 707 Round Nylon	PW707N	Large Round	.551"	16 1/4"	3 1/2"	\$24.80
	Shira Kashi Oak 747 Nylon	PW747N	Oval	.551"	16 1/4"	2 1/2"	\$24.80

PROMARK SHIRA KASHI OAK

55A



Description	Item #	Tip	Diameter	Length	Taper	Retail
Shira Kashi Oak 55A	PW808W	Large Round	.579"	16"	3 1/4"	\$24.00

5B



Description	Item #	Tip	Diameter	Length	Taper	Retail
Shira Kashi Oak 5B	PW5BW	Oval	.590"	16"	2"	\$24.00



Shira Kashi Oak 5B Nylon	PW5BN	Oval	.590"	16"	2"	\$24.80
--------------------------	-------	------	-------	-----	----	---------

5B LONG



Description	Item #	Tip	Diameter	Length	Taper	Retail
Shira Kashi Oak 747 Super Rock	PW747BW	Oval	.590"	16 3/4"	2 1/2"	\$24.00



Shira Kashi Oak 747 Super Rock Nylon	PW747BN	Oval	.590"	16 3/4"	2 1/2"	\$24.80
--------------------------------------	---------	------	-------	---------	--------	---------

2B



Description	Item #	Tip	Diameter	Length	Taper	Retail
Shira Kashi Oak 2B	PW2BW	Oval	.630"	16"	2 1/4"	\$24.00



Shira Kashi Oak 2B Nylon	PW2BN	Oval	.630"	16"	2 1/4"	\$24.80
--------------------------	-------	------	-------	-----	--------	---------

DRUM SET DRUMSTICKS

PROMARK ARTIST SERIES SHIRA KASHI OAK

7A



Stephen A. Perkins

Description	Item #	Tip	Diameter	Length	Taper	Retail
Stephen Perkins 719	PW719W	Large Round	.531"	16 1/4"	3 1/4"	\$25.95

5A



Neil Peart



Joey Jordison



Ed Shaughnessy

Description	Item #	Tip	Diameter	Length	Taper	Retail
Neil Peart 747	PW747W	Oval	.551"	16 1/4"	2 1/2"	\$25.95
Joey Jordison 515	PW515W	Large Round	.551"	16"	2 3/4"	\$25.95
Ed Shaughnessy 707	PW707W	Large Round	.551"	16 1/4"	3 1/2"	\$25.95

2B



Tommy Aldridge



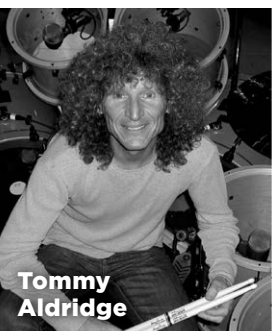

Description	Item #	Tip	Diameter	Length	Taper	Retail
Tommy Aldridge 2S	PW2SW	Oval	.630"	17"	3 7/8"	\$25.95



PROMARK AMERICAN MAPLE

Maple is a very light wood that allows for a larger diameter stick without added weight relative to other woods. Smaller diameter maple sticks are ultra-light for precision and subtlety.

7A



	Description	Item #	Tip	Diameter	Length	Taper	Retail
	Jazz Café 11	MJZ-11	Small Round	.495"	15 3/8"	2 3/4"	\$19.30
MUST★HAVE 	Jazz Café 9	MJZ-9	Small Round	.531"	15 3/8"	4"	\$19.30
	Jazz Café 5	MJZ-5	Acorn	.531"	15 7/8"	4"	\$19.30
	Jazz Café 3	MJZ-3	Acorn	.495"	15 5/8"	3 1/2"	\$19.30

5A

	Description	Item #	Tip	Diameter	Length	Taper	Retail
MUST★HAVE 	Jazz Café 7	MJZ-7	Acorn	.551"	15 3/8"	3 7/8"	\$19.30



2B

NEW!

	Description	Item #	Tip	Diameter	Length	Taper	Retail
	Classic Maple SD1	SD1W	Large Round	.630"	16 3/8"	3 3/8"	\$19.30
	Classic Maple SD2	SD2W	Small Round	.630"	15 3/4"	1 7/8"	\$19.30

PROMARK ARTIST SERIES AMERICAN MAPLE



	Item #	Description	Tip	Diameter	Length	Taper	Retail
MUST★HAVE  <i>Todd Sucherman</i>	SD330W	Todd Sucherman 330	Acorn	.600"	16"	3 1/2"	\$21.80
 <i>Bill Bruford</i>	SD4W	Bill Bruford SD4	Barrel	.531"	15 7/8"	3 1/4"	\$21.80
 <i>Jason Bonham</i>	SD531W	Jason Bonham 531	Acorn	.595"	16 3/4"	3 1/8"	\$21.80

BRUSHES & RODS

Telescopic Wire Brush

With a spectrum of offerings, Promark brushes range from soft & subtle to rigid & robust, and have proven to be essential implements in any stick bag. Made in the USA and held to the highest of quality standards, Promark brushes are suitable for a broad range of genres and performance settings.



TB3 MUST★HAVE



TB4



TB5



TB6

Item #	Description	Handle Diameter	Length w/ Bristles	Length of Handle	Retail
TB3	Telescopic Wire Jazz	.494"	12 5/16"	6 13/16"	\$45.75
TB4	Telescopic Wire Classic	.494"	12 5/16"	7 1/8"	\$50.75
TB5	Telescopic Wire General	.494"	12 5/16"	7 1/16"	\$49.25
TB6	Telescopic Wire Heavy	.630"	13 1/4"	7 1/8"	\$49.25



B300

Item #	Description	Diameter	Length w/ Bristles	Length of Handle	Retail
B300	"Accent" Oak Handle	.622"	13 1/2"	7 1/4"	\$58.85



B400

Item #	Description	Diameter	Length w/ Bristles	Length of Handle	Retail
B400	Blue Nylon Brushes	.622"	13 1/8"	7 3/8"	\$49.65



B600

Item #	Description	Diameter	Length w/ Bristles	Length of Handle	Retail
B600	Nylon Bristle	.630"	13 3/4"	8 1/2"	\$49.65

Broomsticks™

Promark is the pioneer in utilizing natural broomcorn to create truly unique percussive implements. Broomsticks provide more volume than brushes and less volume than Rods, making them the perfect implement for any player seeking to expand their sound palette. Adjustable commercial-grade rubber bands allow for easy variation of tone, articulation and feel. Broomsticks are highly recommended for use on Cajon. Handmade in the USA.

Item #	Description	Diameter	Length	Retail
PMBRM	Large Broomstick	1"	14 1/2"	\$49.65
PMBRM1	Medium Broomstick	7/8"	14 1/2"	\$49.65
PMBRM2	Small Broomstick	3/4"	14 1/4"	\$49.65



PMBRM



PMBRM1 MUST★HAVE



PMBRM2

Rods®

Promark started a trend when they introduced the original Hot Rod, and now there are more choices than ever! When regular sticks are too loud, and brushes are too quiet, Rods are just right. The Promark Rods are handmade in the USA with premium select birch dowels with four sizes to choose from.

C-RODS



Item #	Description	Diameter	Length	Retail
C-RODS	Cool Rods	.425"	16"	\$39.70

MUST★HAVE

H-RODS



Item #	Description	Diameter	Length	Retail
H-RODS	Hot Rods	.560"	16"	\$39.70

L-RODS



Item #	Description	Diameter	Length	Retail
L-RODS	Lightning Rods	.530"	16"	\$39.70

T-RODS



Item #	Description	Diameter	Length	Retail
T-RODS	Thunder Rods	.675"	16"	\$39.70

WORLD & ALTERNATIVE SOUNDS

Promark Classic World & Alternative



Item #	Description	Diameter	Length	Retail
SH516	Sabar 516 - 4 Pairs	.312"	15 1/2"	\$32.25



Item #	Description	Diameter	Length	Retail
TH716	Timbale 716 - 4 Pairs	.437"	15 3/4"	\$42.20



Item #	Description	Diameter	Length	Retail
FC3	Fausto Cuevas III "Rumbero" FC3 - 2 Pairs	.485"	16 1/2"	\$46.05



Item #	Description	Diameter	Length	Retail
TH816	Mambo 816 - 4 Pairs	.500"	15 3/4"	\$48.00



Memo Acevedo

Item #	Description	Diameter	Length	Retail
MA1	Memo Acevedo "Revolution" MA1 - 6 Pairs	.585" tapering to .415"	16"	\$19.30

TUBZ

Invented by Paul Wertico, TUBZ are hollow and made out of pliable, semi-flexible plastic. Great for producing a bongo-like sound when struck on any solid surface. Use on cymbals, snare, congas, timbales, bongos or anything else you can imagine for new and different sounds.



Item #	Length	Diameter	Retail
TUBZ	16 1/2"	1 1/4"	\$22.65



Light Multi-Percussion Stick - Hickory

Item #	Description	Length	Diameter	Retail
TXSD5W	SD5 Wood Tip, Felt Butt End	16 1/4"	.551"	\$54.85



Light Multi-Percussion Stick - Maple

Item #	Description	Length	Diameter	Retail
SD6	SD6 Wood Tip, Felt Butt End	16"	.610"	\$60.35



MUST★HAVE

Multipurpose Felt Mallet

The MT3 features a medium-hard felt head and is excellent for cymbal swells or general mallet work.

Item #	Description	Length	Diameter	Retail
MT3	MT3 Medium-Hard, Felt	14 1/4"	.600"	\$66.80



Nick Petrella Multi-Percussion Mallet

The metal sleeve provides extra weight for a full tone and an excellent alternative to a triangle beater. The parachute-wrapped head delivers the right balance of articulation and tone.

Item #	Length	Diameter	Retail
NP318R	16 1/2"	.335"	\$87.00

Stick Rapp™

Promark Stick Rapp is a soft, comfortable wrap for sticks that absorbs shock and provides a non-slip grip in stylish colors.

Item #	Description	Retail
SRBLA	Black	\$18.65
SRBLU	Blue	\$18.65
SRWHI	White	\$18.65
SRCR	Checkerboard - Black/Red	\$18.65
SRCW	Checkerboard - Black/White	\$18.65
SR3BLA	Splatter - Black	\$15.80

MUST★HAVE



MUST★HAVE

Everyday Stick Bag

The Everyday Stick Bag is Promark's redesigned entry-level stick bag for drum set and concert players. Made from durable, weatherproof ballistic nylon, this bag is built to withstand the wears of the road both on and off stage. The PEDSB features ergonomic carrying handles, a large front-zippered pocket, heavy duty outer-bag zipper for reliable opening and closing, a zippered inner pocket, hanging tom-mounts, and ample drumstick storage within. Attention to quality, durability, detail, and simplicity will make this bag a favorite for budget-conscious working drummers.

Item #	Retail
PEDSB	\$45.50



MUST★HAVE

Sliver Essentials Stick Bag

The Sliver Essentials Stick Bag is part of a new, high-quality line of stick bags designed with the gigging musician in mind. Made from durable, weatherproof ballistic nylon and synthetic leather, this bag is built to withstand the wears of the road both on and off stage while allowing drummers to travel in style. The SESB features metal hanging hooks and a leather tension rod eyelet to keep the bag secured to a floor tom while playing. With enough room to fit four pairs of drumsticks comfortably, this bag allows gigging musicians to travel with the essential tools for any gig without extra trips back to the car.

Item #	Retail
SESB	\$43.25



MUST★HAVE

Transport Deluxe Stick Bag

The Transport Deluxe Stick Bag is part of a new, high-quality line of stick bags designed with the gigging musician in mind. Made from durable, weatherproof ballistic nylon and synthetic leather, this bag is built to withstand the wears of the road both on and off stage while allowing drummers to travel in style. The TDSB features magnetic secured, leather carrying handles, a large front-zippered pocket, a zippered interior pocket, metal hanging tom-mounts, a leather business card slot, a metal key leash, a pencil slot, a deluxe leather pocket for your wallet and cell phone, and ample drumstick storage. With a specific spot for all of your personal belongings, there's no need to worry about misplacing things during your gigs.

Item #	Retail
TDSB	\$82.75

DRUM SET ACCESSORIES

Rattler & Sizzler

Produces a sound very similar to sizzle cymbals. No holes to drill. Easy to install and remove.



MUST★HAVE

R22

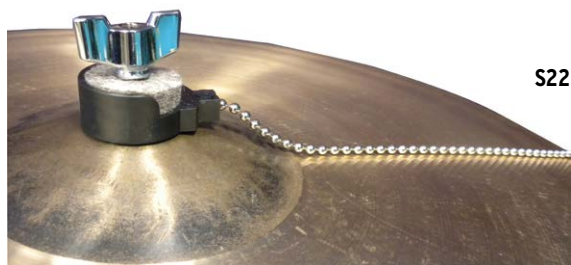

S22

Item #	Description	Retail
R22	Rattler - Large Beads	\$27.15
S22	Sizzler - Small Beads	\$27.15

MUST★HAVE Giant Sticks

Great for parties, display or HEAVY Rock and Roll! Sold in pairs.



Item #	Length	Diameter	Retail
GNT	36"	1.5"	\$89.70

Drum Gloves

Thin-cut Cabretta leather featuring eight specially-placed pads on the four fingers and three on the palm for vastly improved grip. Extra padding on the thumbprint area, fingertips, and knuckles. Breathable mesh on top of all fingers and backside of the hand to reduce perspiration. Adjustable hook-and-loop closing strap does not interfere with wrist motion and provides added wrist support. Pre-rotated fingers help promote natural closure of the hand.

Item #	Description	Retail
DGS	Small	\$99.15
DGM	Medium	\$99.15
DGL	Large	\$102.00
DGXL	Extra Large	\$99.15



Stick Depot

Clamps easily to cymbal stands or other hardware with adjustable tubes to keep your sticks, brushes, or mallets within reach when you need them.



Item #	Description	Retail
SD100	Holds 1 pair of sticks	\$26.20
SD200	Holds 2 pairs of sticks	\$29.05
SD400	Holds 4 pairs of sticks	\$31.60

MARCH TO THE BEAT OF A CHAMPION

STEPHEN CREIGHTON PIPE BAND STICKS

NEW! Stephen Creighton Signature Pipe Band Sticks

Designed with Stephen Creighton, world-renowned drum sergeant of the St. Laurence O'Toole Pipe Band, these drumsticks are made of high quality maple and feature a gradual taper to create the rebound, feel and consistency demanded when performing on a high-tension pipe snare. The series is available in three finish options - standard lacquer for a classic feel, ActiveGrip for unprecedented control, and painted white for high visibility on the playing field.



Item #	Description	Tip	Diameter	Length	Taper	Retail
PBSC	Stephen Creighton Signature Pipe Band Stick	Large Oval	.755"	15 15/16"	Gradual	\$28.70
PBSC-WHT	Stephen Creighton Signature Pipe Band Stick - Painted White	Large Oval	.755"	15 15/16"	Gradual	\$28.70
PBSC-AG	Stephen Creighton Signature Pipe Band Stick - ActiveGrip	Large Oval	.755"	15 15/16"	Gradual	\$30.90



Working with Promark, I went through several iterations to perfect the design of my new signature drumstick. By shifting the weight to the front of the stick and tapering the back of the grip, we created a stick with improved balance and rebound. With Promark's advanced weight and tone sorting processes, and high quality maple, this design makes the perfect pipe band stick.

Stephen Creighton

MARCHING DRUMSTICKS

Promark provides a vast selection of marching snare sticks. This allows band directors and percussion teachers access to many different sounds and musical timbres to fit any passage of music desired on the marching field. From the beefy DC50, to the delicate DC17iw, to the rubber-tipped X-Beat, your sound palette is limitless.



Item #	Description	Length	Diameter	Retail
TXDCBYOSW	BYOS Marching Hybrid	17"	.700"	\$21.80
TXDC17iw	System Blue DC17 Light Indoor	16 5/8"	.650"	\$20.70
TXDC18iw	American Hickory Jeff Ausdemore DC18i	16 13/16"	.680"	\$21.80
TXDC51W	American Hickory System Blue DC51	16 3/4"	.680"	\$21.80
TXDC27W	System Blue DC27 "Scooter"	16 3/4"	.685"	\$20.70
TXXB3	Scott Johnson Rubber-Tipped Stick XB3	17"	.700"	\$47.80
TXDC17W	American Hickory Scott Johnson DC17	17"	.700"	\$21.80
TXDC50W	American Hickory System Blue DC50	16 7/8"	.720"	\$21.80
TXDC8W	American Hickory Jeff Ausdemore DC8	17"	.730"	\$21.80

TOP MARCHING STICKS

1. TXDC17W SCOTT JOHNSON DC17
2. TXDBYOSW BYOS HYBRID MARCHING
3. TXDC50W SYSTEM BLUE DC50
4. TXDC8W JEFF AUSDEMORE DC8
5. TXDC27W SCOTT JOHNSON DC27 "SCOOTER"

MARCHING TENOR MALLET

Marching Tenor Mallets

From aluminum handles to wood shafts with various head shapes and materials, the Promark line of tenor mallets allows band directors and percussion teachers various tonal options for their tenor line.



Item #	Description	Retail
ATA1	Aluminum Shaft with Nylon Cookie Head	\$66.80
ATA2	Aluminum Shaft with Felt Head	\$79.05
ATA2S	Aluminum Shaft with Puffy Head	\$87.00
ATA3	Aluminum Shaft with Acrylic Head	\$66.80
ATA4	Aluminum Shaft with Rubber Head	\$66.80

Item #	Description	Retail
ATA20i	Aluminum Shaft with Nylon Head	\$66.80
ATH1	Hickory Shaft with Nylon Cookie Head	\$66.80
ATH2	Hickory Shaft with Felt Head	\$72.90
ATH2S	Hickory Shaft with Puffy Head	\$79.05

MUST★HAVE

Marching Tenor Signature Mallets



Item #	Description	Length	Diameter	Retail
TS7	Mike Stevens Hickory with Nylon Head	16"	.700"	\$47.80
TS8	Sean Vega Hickory with Nylon Head System Blue	16 7/8"	.730"	\$44.75



The TS8 was designed to accommodate all of a performer's needs on a set of tenor drums, as well as a drum pad. By marrying an appropriate length for getting around drums, and the perfect weight for an optimal rebound on both drums and a pad, Promark has created the perfect tool for practice and performance.

Sean Vega

MARCHING BASS DRUM MALLETS

Performer Series "Puffy" Marching Bass Drum Mallets

Performer Series "Puffy" Marching Bass Drum Mallets are made with select grade American Hickory handles, and a special fleece covering that softens articulation and controls overall volume. The perfect choice for light or softer sounding passages, Performer Series "Puffy" mallets feature a "Comfort Flare" that improves grip while an upward taper at the head provides exceptional balance and tone.



Item #	Description	Retail
PSMB1S	Soft - Best for 14-18" drums	\$79.05
PSMB2S	Soft - Best for 18-22" drums	\$87.65
PSMB3S	Soft - Best for 22-26" drums	\$96.20
PSMB4S	Soft - Best for 26-28" drums	\$115.20
PSMB5S	Soft - Best for 28-32" drums	\$133.90

Performer Series Marching Bass Drum Mallets

Performer Series Marching Bass Drum Mallets are made with select grade American Hickory handles and a special extra-dense felt head. A practical choice for any bass line, whether beginners, college players, or competitive drum corps, the "Comfort Flare" grip makes them easy to hold on to while the upward taper at the head means exceptional balance and sound projection. The series is available in five sizes and is also available in a soft, "puffy" version.



Item #	Description	Retail
PSMB1	1 3/8" Head - Best for 14-18" drums	\$72.30
PSMB2	1 1/2" Head - Best for 18-22" drums	\$76.30
PSMB3	1 3/4" Head - Best for 22-26" drums	\$83.05
PSMB4	2" Head - Best for 26-28" drums	\$101.70
PSMB5	2 1/4" Head - Best for 28-30" drums	\$120.40

MARCHING BASS DRUM & TENOR MALLETS

Optima Series Marching Bass Drum Mallets

The Optima Marching Bass Drum Mallets feature a uniquely contoured American Hickory handle with a special weight ring at the base of the felt head. The weight ring helps provide improved balance, increased head velocity, and enhanced sound projection. Hard felt elliptical-shaped heads produce a focused bass tone without denting the head.



Item #	Description	Retail
OBD1	1 3/8" Head - Best for 14-18" drums	\$79.05
OBD2	1 1/2" Head - Best for 18-22" drums	\$84.25
OBD3	1 3/4" Head - Best for 22-26" drums	\$89.75
OBD4	2" Head - Best for 26-28" drums	\$102.95
OBD5	2 1/4" Head - Best for 28-30" drums	\$113.65

Traditional Series

High-quality, affordable marching mallets for tenor and bass drums. Solid heads epoxied to lightweight, black satin aluminum shafts for long-lasting mallets that feature soft, non-slip grips.



Item #	Description	Retail
M330T	Felt Tenor Mallet	\$71.10
M331T	Acrylic Tenor Mallet	\$83.05
M332T	Rubber Tenor Mallet	\$66.80
M320S	Small Felt Bass Drum Mallet	\$92.20
M321M	Medium Felt Bass Drum Mallet	\$100.50
M322L	Large Felt Bass Drum Mallet	\$129.90

CONCERT SNARE DRUMSTICKS

NEW! Matthew Strauss Signature General Snare Drumsticks

The Matthew Strauss General are designed with a long taper to harness the energy generated from the rebound. This persimmon stick also allows for a smoother and more consistent roll resulting from an elongated tip which provides a greater surface contact between the stick and head.



Item #	Description	Tip	Diameter	Length	Taper	Retail
MS1	Matthew Strauss General	Arrow	.670"	17"	5 1/2"	\$40.25

NEW! Matthew Strauss Signature Staccato Snare Drumsticks

Inspired by a prominent characteristic from the drum set stick arena, the Matthew Strauss Staccato sticks are designed with a nylon tip to further enhance clarity with a brighter color. The disc-shaped tip promotes a high level of consistency for double strokes. This persimmon stick is a dream come true for the serious snare drummer.



Item #	Description	Tip	Diameter	Length	Taper	Retail
MS2N	Matthew Strauss Staccato	Nylon Disc	.630"	15 7/8"	3"	\$45.80

Concert One Snare Drumstick

The Concert One Snare Drumstick was designed as an intermediate level drumstick with styling and function suitable for professional players – an excellent option for the player seeking to push the boundaries of performance that a traditional SD1 simply cannot achieve due to its limiting design characteristics. The diameter, long taper and large oval tip promotes proper playing technique as well as proper balance and consistency throughout a wide range of playing styles. The immediate feedback the stick provides promotes more rapid development in up-and-coming players while assisting with challenging passages to help sustain motivation during the learning process.



Item #	Description	Tip	Diameter	Length	Taper	Retail
TXC1W	Concert One Snare Drumstick	Large Oval	.645"	16 7/8"	4 1/2"	\$17.65

Concert Two Snare Drumstick

The Concert Two Snare Drumstick is the next product in the Promark concert series designed for students and professionals alike. Keeping in mind the challenges students encounter, the Concert Two builds on the fundamentals catered to by the Concert One. As students advance and begin to encounter more difficult repertoire with more intricate passages, they need a tool to help facilitate playing at that level. The Concert Two features a smaller round bead that provides ideal articulation at a wide dynamic range. The rear taper pushes the balance of the stick slightly forward, helping to achieve a balanced feel and better response from the drumhead. At .630" in diameter, a relaxed technique can be achieved at all times, thus the C2 is an essential tool for the developing percussionist's collection.



Item #	Description	Tip	Diameter	Length	Taper	Retail
TXC2W	Concert Two Snare Drumstick	Round	.630"	16 7/8"	4"	\$18.50



Item #	Description	Tip	Diameter	Length	Taper	Retail
TXSD1W	Classic SD1	Large Round	.630"	16 3/8"	3 5/8"	\$19.30



Item #	Description	Tip	Diameter	Length	Taper	Retail
SD1W	Classic Maple SD1	Large Round	.630"	16 3/8"	3 3/8"	\$19.30



Item #	Description	Tip	Diameter	Length	Taper	Retail
TX740W	Dame Evelyn Glennie 740	Barrel	.630"	16 1/8"	4"	\$21.75

Performer Series Concert Bass

PSBDR



PSBD3



PSBD5



Item #	Description	Retail
PSBDR	Rollers Concert Bass Drum Beater - Pair	\$254.30
PSBD3	General Bass Drum Beater	\$127.15
PSBD5	Legato/Soft Bass Drum Beater	\$145.85

Performer Series Gong

PSGB1



PSGB2



Item #	Description	Retail
PSGB1	Large Gong Beater	\$105.70
PSGB2	Small Gong Beater	\$92.20

KEYBOARD MALLETs

System Blue™ Diversity Series

As the name implies, this series has been designed by The Blue Devils percussion staff to be a diverse line of mallets for indoor and outdoor percussion. The eight mallets in this line cater to a variety of players and educators by featuring four graduated vibraphone mallets and four graduated marimba mallets designed for use with natural or synthetic bars. These mallets hold up to any musical demand while still achieving a true, fundamental tone from the keyboard, and are perfect for ensembles seeking clarity and articulation.

Item #	Wood	Articulation	Instrument	Retail
DV1	Birch	Soft	Marimba	\$65.00
DV2	Birch	Medium-Soft	Marimba	\$65.00
DV3	Birch	Medium-Hard	Marimba	\$65.00
DV4	Birch	Hard	Marimba	\$65.00
DV5R	Rattan	Soft	Vibe	\$104.10
DV6R	Rattan	Medium-Soft	Vibe	\$104.10
DV7R	Rattan	Medium-Hard	Vibe	\$104.10
DV8R	Rattan	Hard	Vibe	\$104.10



System Blue™ Jim Wunderlich Series

The Jim Wunderlich Series marimba mallets feature a rubber-like synthetic core wrapped tightly with durable synthetic yarn on a lacquered birch shaft for a smooth finish with maximum strength. The vibe mallets feature a rubber-like synthetic core wrapped tightly with cord on a rattan shaft. While they have durable components for outdoor environments, the lush tone of these mallets is an appropriate and tasteful choice for indoor concert or marching settings.

Item #	Wood	Articulation	Instrument	Retail
JW1	Birch	Soft	Marimba	\$79.40
JW2	Birch	Medium-Soft	Marimba	\$79.40
JW3	Birch	Medium	Marimba	\$79.40
JW4	Birch	Medium-Hard	Marimba	\$79.40
JW5	Birch	Hard	Marimba	\$79.40
JW6R	Rattan	Soft	Vibe	\$93.75
JW7R	Rattan	Medium	Vibe	\$93.75
JW8R	Rattan	Medium-Hard	Vibe	\$93.75
JW9R	Rattan	Hard	Vibe	\$93.75



Performer Series

Promark Performer Series marimba mallets are designed specifically to fit the needs of the most discerning player. The high level of craftsmanship and tonal qualities throughout this line is ideal for the professional player, serious students, and teachers, and perfect for those solo pieces in which the player would like to use a graduated set of mallets.



Item #	Wood	Articulation	Retail
PSM10	Birch	Soft	\$65.00
PSM20	Birch	Medium-Soft	\$65.00
PSM25	Birch	Medium	\$65.00
PSM30	Birch	Medium-Hard	\$65.00



Item #	Wood	Articulation	Description	Retail
PSX10R	Rattan	Soft	1-1/4" Rubber Ball	\$65.65
PSX20R	Rattan	Medium	1-1/4" Nylon Ball	\$65.65
PSX30R	Rattan	Medium-Hard	1-1/8" Nylon Ball	\$65.65
PSX50R	Rattan	Hard	1-1/4" Teflon Ball	\$71.55
PSX80R	Rattan	Medium	1-1/8" Poly Ball	\$65.55
A-XYL02	Lexan	Hard	1-1/8" Lexan	\$58.15

Dame Evelyn Glennie Series

Dame Evelyn Glennie, virtuoso percussionist, created a line of marimba mallets that are tightly wrapped with cord for clear and consistent articulation at all dynamic levels.

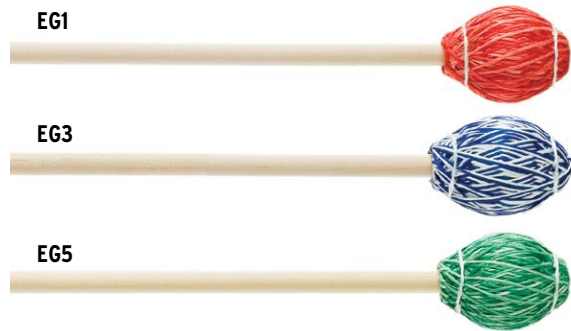

Item #	Wood	Articulation	Retail
EG1	Birch	Soft	\$75.00
EG3	Birch	Medium	\$75.00
EG5	Birch	Hard	\$75.00

Vibraphone Mallets

This range of vibraphone mallets includes various tonal characteristics for solo play or comping. From the articulate sound of the Lionel Hampton stick to the warmth of the Milt Jackson stick, each vibraphone mallet allows the player to produce their own sound.



Item #	Description	Wood	Articulation	Retail
PLH	Lionel Hampton	Rattan	Medium-Hard	\$88.75
PMJ	Milt Jackson	Rattan	Medium	\$92.20
PJM	Jon Metzger	Rattan	Medium-Hard	\$88.75
PBM	Bill Molenhof	Birch	Medium	\$88.75

KEYBOARD MALLETs

Discovery/Orff Series

The Discovery Series is designed for use on Orff and other instruments in the elementary music classroom. The mallets in this series exhibit exceptional quality and unequaled durability with fiberglass handles fitted with rubber grips that won't come off. All Discovery Series mallets are color-coded for fast, easy selection.

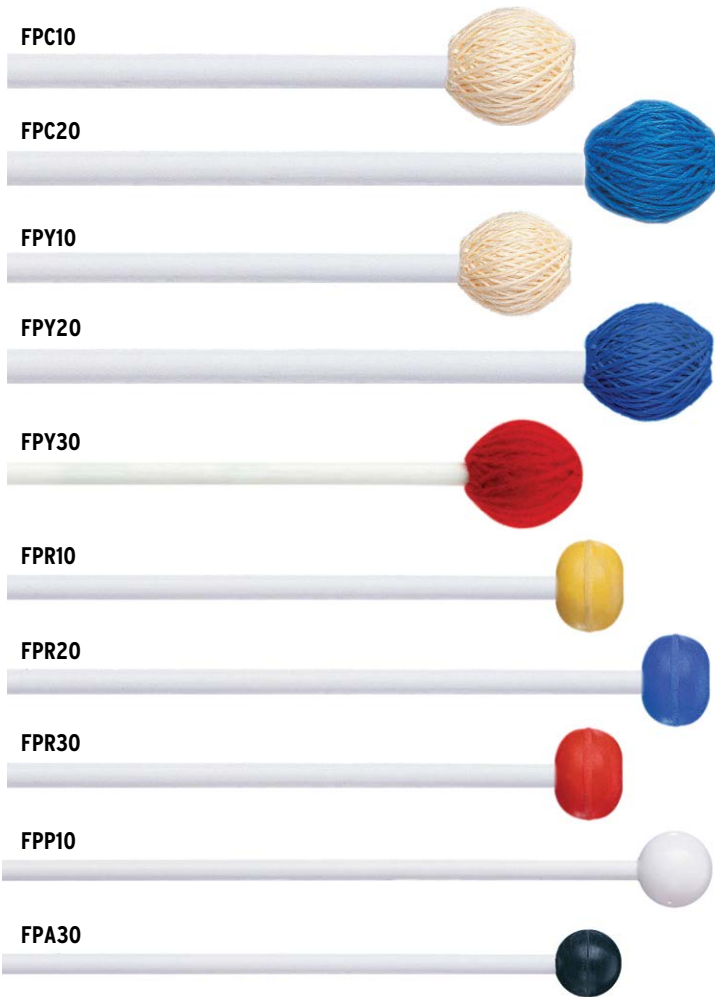

Item #	Description	Articulation	Retail
FPC10	Yellow Cord	Soft	\$33.45
FPC20	Blue Cord	Medium	\$33.45
FPY10	Yellow Yarn	Soft	\$33.45
FPY20	Blue Yarn	Medium	\$33.45
FPY30	Red Yarn	Hard	\$33.45
FPR10	Yellow Rubber	Soft	\$29.40
FPR20	Blue Rubber	Medium	\$29.40
FPR30	Red Rubber	Hard	\$29.40
FPP10	White Phenolic	Very Hard	\$34.05
FPA30	Black Rubber	Very Hard	\$34.05

Dan Fyffe Mallets

The Dan Fyffe scholastic mallets were designed for the student musician. The mallets' light weight makes them easy to control and minimizes player fatigue. The series has 8 different pairs of mallets to choose from, making the series very versatile and able to meet the scholastic performer's musical needs for multiple performance situations.

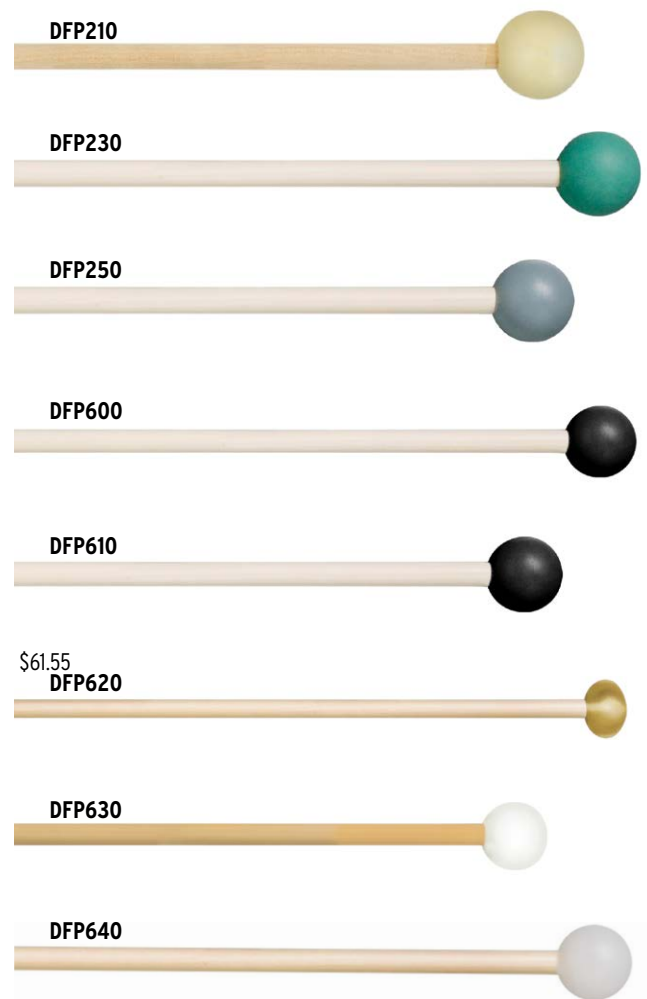

Item #	Wood	Articulation	Description	Retail
DFP210	Birch	Soft	1 1/8" Rubber Ball	\$40.95
DFP230	Birch	Medium	1 1/8" Rubber Ball	\$40.95
DFP250	Birch	Hard	1 1/8" Rubber Ball	\$40.95
DFP600	Rattan	Hard	1" Phenolic Ball	\$61.55
DFP610	Rattan	Hard	1 1/8" Phenolic Ball	\$61.55
DFP620	Rattan	Very Hard	Brass Ball	\$61.55
DFP630	Rattan	Medium-Hard	1" Poly Ball	\$58.15
DFP640	Rattan	Hard	1 1/8" Poly Ball	\$58.15

Jonathan Haas Artist Series

The Jonathan Haas Artist Series timpani mallets are constructed with oak handles. The series is composed of eight different models ranging from the softest JH6 used for smooth rolls to the JH7 which have a wooden head for ultra staccato play.



Item #	Wood	Articulation	Retail
JH1	Oak	Ultra Staccato	\$85.80
JH2	Oak	Staccato	\$88.25
JH3	Oak	Hard	\$91.00
JH4	Oak	Medium	\$93.75
JH5	Oak	Medium-Soft	\$96.20
JH6	Oak	Soft	\$113.65
JH7	Oak	Ultra Staccato	\$73.55

Performer Series Timpani Mallets

The Performer Series Timpani Mallets are an excellent choice for any percussionist from beginner to professional. All five models are crafted with tapered maple shafts which offer excellent feel and response. All heads are wrapped with professional-quality felt and feature a seamless parachute-style wrap which offers a consistent playing area around the entire surface of the mallet head.



Item #	Wood	Articulation	Retail
PST1	Maple	Soft	\$66.80
PST2	Maple	Medium-Soft	\$66.80
PST3	Maple	General	\$66.80
PST4	Maple	Hard/Staccato	\$66.80
PST5	Maple	Ultra Staccato	\$66.80



Jonathan Haas Recover Kits

Item #	Description	Retail
JH1R	For JH1 - Green	\$11.95
JH2R	For JH2 - Red	\$11.95
JH3R	For JH3 - White	\$11.95
JH4R	For JH4 - White	\$11.95
JH5R	For JH5 - White	\$11.95

BAND & ORCHESTRA ACCESSORIES



Hanging Mallet Bag

This new-and-improved, fully redesigned mallet bag is engineered to open 180 degrees across and hang securely on marimbas, vibraphones and xylophones. Features enough space to accommodate a full mallet collection for virtually any size performance, with a large zipper pocket on the back for sheet music and accessories. Sized appropriately to hang two bags across any 4.3 octave marimba, full-size vibes and xylophones. This bag is made of rugged ballistic nylon with wide pockets that allow for quick mallet changes, even with mallet heads facing downward, and features on-the-fly rain guard flaps for quick cover from the elements.

Item #	Retail
PHMB	\$90.95



Marching Drumstick Bags

New and improved single and two-pair bags are designed to fit securely on marching snare drums, tenors and more. Features enough space for one pair or two pairs of sticks and made of rugged ballistic nylon. Engineered to allow for quick stick changes with slick interior denier material.

Item #	Description	Retail
PQ1	Holds 1 pair	\$21.15
PQ2	Holds 2 pairs	\$34.45



White Stick Tape

1" wide tape in 108ft. rolls for the ultimate marching stick tape.

Item #	Retail
ATWHI	\$18.00



Keiko Abe Mallet Wrap

Promark Keiko Abe mallet wrap was designed specifically for use with marimba and vibraphone mallets. The mallet wrap provides extra grip, which can be quite beneficial when using four-mallet techniques.

Item #	Description	Retail
MWBLA	Black	\$16.40
MWBLU	Blue	\$16.40

DISPLAYS



Snare Stand Drumstick Display

Update your Promark Snare Stand Display in style with this updated graphic retrofit kit. Implementing a new key-model taxonomic structure, this artwork kit updates your existing display to focus on our premium technology and top selling drumstick models in an interactive, silent-salesman style POP display. With this updated retrofit kit, customers have the opportunity to test a variety of essential, tried and true Promark models to discover their preferred stick of choice while also exploring our premium technology options in ActiveGrip and FireGrain. Minimum assembly is required to apply the retrofit kit.

Item #	Description
PMSSDD	Minimum assembly required, graphic preloaded
PMSSDD-RETROFIT	Bin labels for Acorn models

A note from Sales

D'Addario offers a variety of display options for your store. Contact your sales rep to learn more.

1-800-268-6855 or orders@daddario.com

Countertop Display and Signage Kit

The new and improved Promark Countertop Display and Signage Kit delivers the storage and functionality of its predecessor with an attractive, updated design. This display has room for 16 drumstick models, allowing you to keep all of the top-selling items at a convenient POP location. Slatwall siding also allows room to display a variety of rods, brushes, broomsticks and accessories. The updated Signage Kit brings the product name to the forefront while panels highlight new product technologies and brand initiatives. Eye-catching Promark yellow side panels will help draw customers from afar.

Item #	Description	Qty.
PROSH	Top Sign Holder	1
PROLEGS	Set of 4 Legs	1
PROHOOKS	Set of 10 Display Hooks	1
PMD-PROKITA	Signage Kit	1
PROBIN	Storage Bin	1



Shelf Talkers

Item #	Description	Qty.
PST-AG	ActiveGrip Shelf Talker	1
PST-ACORN	Acorn Tip Shelf Talker	1



ORCHESTRAL

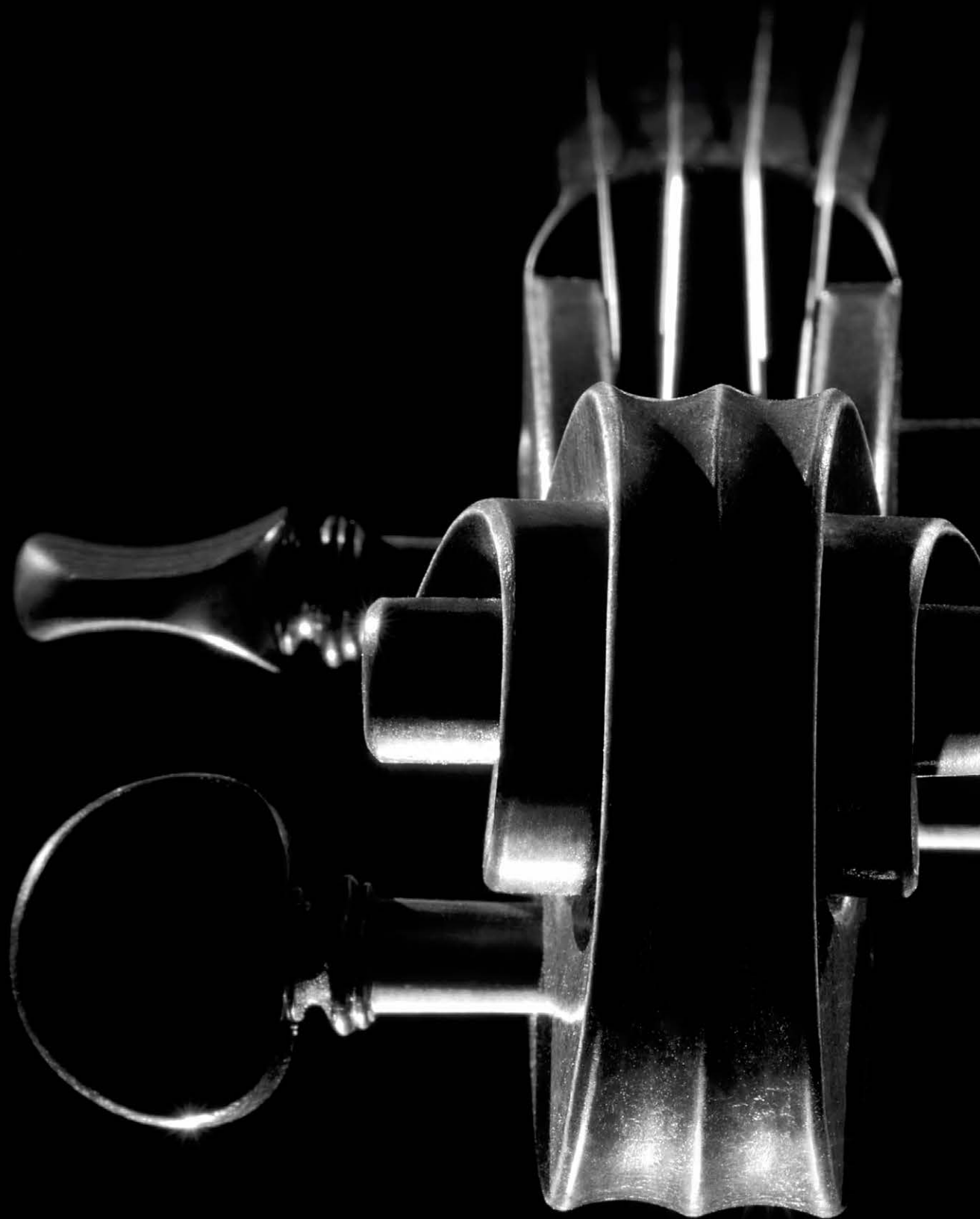

ELEVATING OUR CRAFT

Each year, we love attending music education conventions and meeting with amazing string teachers from around the world. Through years of interacting among the teaching community, we have gained immense insight into the world of string pedagogy. With this knowledge, we have been able to fine-tune our craft of string-making to suit the exact needs of teachers globally.

Over the years, the demands of teaching have changed. Now, with growing classrooms, tighter budgets, and increasingly diverse needs, string educators have to make more informed decisions at every level, including their choice of strings. In speaking with teachers, we heard the same request again and again: create a synthetic core string to provide students with a sophisticated sound at an entry-level price.

With that in mind, we spent many months researching new materials and manufacturing techniques. In an effort to improve the experience of using synthetic core strings on students' instruments, we also set out to increase their pitch-stability and longevity, features that are valued by classroom and private teachers alike. We then set out to create the perfect combination of great sound and durability. In mid-2017, we proudly released the **Ascenté Violin Set**.



2018 will find us continuing to focus on the Ascenté line as we develop a set for viola students with similar benefits. We have also turned our attention to professional cellists and will have some exciting news for them later in the year. On the factory floor, we continue to work relentlessly on improvement of consistency, efficiency, and our manufacturing process, ensuring higher quality standards year after year.

Look for us at your next music conference! We look forward to sharing our latest innovations with you.

TOP SELLERS & MUST HAVES



PRELUDE VIOLIN STRINGS

J810 4/4M
(See page 170)



NEW! ASCENTÉ VIOLIN STRINGS

A310 4/4M
(See page 170)



PRO•ARTÉ VIOLIN STRINGS

J56 4/4M
(See page 170)



ZYEX VIOLIN STRINGS

DZ310A 4/4M
(See page 169)



HELICORE VIOLA STRINGS

H410 LM
(See page 172)



KAPLAN FORZA VIOLA STRINGS

K410 LM
(See page 171)



KAPLAN AMO & KAPLAN VIVO VIOLIN STRINGS

KA310 4/4M, KV310 4/4M
(See page 168)



KAPLAN AMO & KAPLAN VIVO VIOLA STRINGS

KA410 LM, KV410 LM
(See page 171)

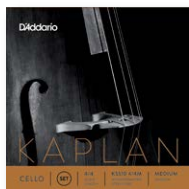

KAPLAN CELLO STRINGS

KS510 4/4M
(See page 173)



KAPLAN BASS STRINGS

K610 3/4M
(See page 175)



KAPLAN PREMIUM ROSIN

KRDL, KRDD
(See page 177)



D'ADDARIO NATURAL ROSIN

VR200, VR300
(See page 177)

VIOLIN STRINGS

Kaplan™ Amo and Kaplan Vivo Violin Strings



Kaplan Violin Strings offer professional-level players an unprecedented combination of beauty and power in two options, Kaplan Amo and Kaplan Vivo. Kaplan Amo provides warmth, richness, and flexibility for brighter instruments, while Kaplan Vivo delivers brilliance, clarity, and a robust feel for darker instruments. Both sets settle quickly, exhibiting a rich tonal color palette and superb bow response.

- 4/4 scale violin with a playing length of 13 inches (328mm)
- Synthetic core produces a rich, powerful tone
- Short break-in time and excellent bow response provide superb playability

Kaplan Amo Full Size

Item #	Description	Tension			Retail
		4/4L	4/4M	4/4H	
KA311	E-tinned high-carbon steel	16.8	17.5	18.6	\$13.60
KA312	A-aluminum	11.8	12.5	13.2	\$34.35
KA313	D-silver	9.7	10.5	11.2	\$55.10
KA314	G-silver	9.7	10.5	11.2	\$70.00
KA310	Set coiled				\$172.30

Kaplan Vivo Full Size

Item #	Description	Tension			Retail
		4/4L	4/4M	4/4H	
KV311	E-tinned high-carbon steel	16.8	17.5	18.6	\$13.60
KV312	A-aluminum	11.8	12.5	13.2	\$34.35
KV313	D-silver	9.7	10.5	11.2	\$55.10
KV314	G-silver	9.7	10.5	11.2	\$70.00
KV310	Set coiled				\$172.30



Kaplan™ Non-whistling Violin E String

The Kaplan Non-whistling Violin E String is designed specifically to combat open E whistles and harmonics. It produces a warm, rich tone that blends very well with A, D, and G violin strings.

Includes one FREE Kaplan Ball End Adapter for use with single hook-style fine tuners.

- Available in 4/4 size only
- Available in medium tension only

Item #	Description	Tension	Retail
KS311W 4/4M	E-aluminum wound	18.6	\$18.20



D'Addario Kaplan strings create a beautiful sound. I can fully rely on them to keep the tuning instantly.

Julia Fischer



Kaplan™ Gold Violin E Strings

Kaplan Gold E Strings offer the traditional, rich sound expected from a high-quality, gold-plated steel violin E string. This precise plating process also enhances corrosion resistance.

- Available in 4/4 size only
- Available in medium tension only
- Available in ball or loop end

Item #	Description	Tension	Retail
K311GB 4/4M	Gold-plated E, ball end	18.6	\$15.65
K311GL 4/4M	Gold-plated E, loop end	18.6	\$15.65



D'Addario Kaplan strings are impressively fast when it comes to tuning stability. The responsiveness and warmth in the sound make these strings unlike any other!

Sirena Huang



Kaplan™ Golden Spiral Solo Violin E Strings

The Kaplan Golden Spiral Solo line offers a wide variety of steel core E strings in light, medium, heavy, and extra heavy tension – the last of which can produce a warmer or more powerful sound than a traditional tension (18.6 pounds) E string.

- Available in 4/4 size only
- Available in ball or loop end

Item #	Description	Tension	Retail
E-tinned high-carbon steel			
K420B-1	Light tension, ball end	15.2	\$8.45
K420B-3	Medium tension, ball end	16.8	\$8.45
K420B-5	Heavy tension, ball end	18.2	\$8.45
K420B-7	Extra heavy tension, ball end	20.4	\$8.45
K420L-1	Light tension, loop end	15.2	\$8.45
K420L-3	Medium tension, loop end	16.8	\$8.45
K420L-5	Heavy tension, loop end	18.2	\$8.45
K420L-7	Extra heavy tension, loop end	20.4	\$8.45
E-aluminum wound on steel core			
K301W	Medium tension, loop end	16.3	\$17.45



Zyex[®] Violin Strings

Zyex Violin Strings have been designed for the most demanding musicians. They are crafted with a highly refined Zyex synthetic core material, giving them a balanced, rich sound and excellent bow response. The Zyex core provides each string with pitch stability and fast break-in time. Zyex strings work well on both modern and brighter-sounding instruments.

- Available in 4/4, 3/4, 1/2, 1/4, 1/8 (fits 1/10), and 1/16 size
- 4/4 size available in light, medium, and heavy tension
- Fractional sizes available in medium tension only

Full Size Item #	Description	Tension			Retail
		4/4L	4/4M	4/4H	
DZ311	E-tinned high-carbon steel	16.8	18.6	20.4	\$9.85
DZ312	A-aluminum	11.3	12.5	13.7	\$26.40
DZ313A	D-aluminum	9.5	10.5	11.5	\$30.25
DZ313S	D-silver	9.3	10.6	11.4	\$38.05
DZ314	G-silver	9.3	10.0	11.0	\$42.15
DZ310A	Set coiled (aluminum D)				\$107.65
DZ310S	Set coiled (silver D)				\$115.15

Fractional Sizes

Item #	Description	Retail
DZ311	E-tinned high-carbon steel	\$8.55
DZ312	A-aluminum	\$17.35
DZ313	D-aluminum	\$20.95
DZ314	G-silver	\$32.60
DZ310	Set coiled	\$78.40



Helicore[™] Violin Strings

Helicore multi-stranded steel core strings are aimed at advanced players. These strings produce a warm and clear sound and a high level of pitch stability. The stranded steel core yields an extremely quick break-in time. Helicore strings are comfortably playable with quick bow response due to the strings' small diameter. For rigorous playing, use with fretted instruments, or protection from corrosive elements, the titanium A string provides an alternative to the standard aluminum Helicore A string. A 5-string Helicore violin set is also available and includes an additional low C string.

- Available in 4/4, 3/4, 1/2, 1/4, 1/8 (fits 1/10), and 1/16 size
- 4/4 size available in light, medium, and heavy tension
- Fractional sizes available in medium tension only
- H312T, H315, & HE310-5 available in 4/4 size, medium and heavy tension only

Full Size Item #	Description	Tension			Retail
		4/4L	4/4M	4/4H	
H311	E-tinned high-carbon steel	16.8	18.6	20.4	\$8.75
H311W	E-aluminum wound	16.3	18.1	19.9	\$16.00
H312	A-aluminum	11.7	12.7	13.6	\$22.00
H312T	A-titanium		12.2	13.5	\$24.75
H313	D-titanium	9.2	11.5	12.2	\$26.50
H314	G-silver	9.2	10.2	11.4	\$31.25
H315	C-tungsten/silver (low C)		11.1	12.4	\$41.25
H310	Set coiled (aluminum A)				\$86.75
H310W	Set coiled (aluminum E)				\$94.50
HE310-5	Set 5-string				\$126.50

Fractional Sizes

Item #	Description	Retail
H311	E-tinned high-carbon steel	\$8.00
H312	A-aluminum	\$17.25
H313	D-aluminum	\$20.50
H314	G-nickel	\$24.00
H310	Set coiled	\$68.25

MUST★HAVE



Helicore[™] Octave Violin Strings

The Helicore Octave Violin set is designed to be played one octave below traditional tuning for a new world of tonal and stylistic possibilities. It utilizes the same core technologies as the original violin set for quick bow response, comfortable playability, and clear sound.

- Designed to be played one octave below traditional violin tuning, accessing most of the cello range
- Utilizes the same core technologies as the original Helicore violin set
- Clear, focused tone
- Great pitch stability

Full Size Item #	Description	Tension	
		4/4M	Retail
H351	E (E4)-titanium/aluminum	13.6	\$24.00
H352	A (A3)-silver	12.6	\$29.00
H353	D (D3)-tungsten/silver	12.0	\$35.00
H354	G (G2)-tungsten/silver	11.0	\$43.00
H350	Set coiled		\$130.00



NS Electric Violin Strings

The set consists of regular-tuning strings (E, A, D, G). An additional 5th string, a low C, is available as a single.

Item	Description	Tension	Retail
NS311	E	18.6	\$7.55
NS312	A	12.7	\$19.85
NS313	D	11.5	\$23.75
NS314	G	10.2	\$27.65
NS315	Low C	12.4	\$36.90
NS310	Set		\$77.40



Helicore Octave Violin strings are clear, the pitch stability is fantastic, and because they're by D'Addario, I know the strings are made with the highest quality.
Mark Evitts

VIOLIN STRINGS

MUST★HAVE



NEW! Ascenté Student Synthetic Violin Strings

D'Addario Ascenté strings are specifically designed to help players advance their craft. With a wider tonal range, excellent pitch stability and longevity, and superior durability, this synthetic core string gives all musicians a more sophisticated palette that elevates their playing to the next level.

- Available in 4/4, 3/4, and 1/2
- Medium tension
- Synthetic core produces a warm, wide tonal range
- Superior pitch stability and durability
- Short break-in time and excellent bow response for superb playability
- Dramatically outperforms all competitors in corrosion tests
- Performs at the highest level of resilience against all competitors
- For advancing students seeking a synthetic string at a price point traditionally associated with steel core strings.

Full Size		Tension			Retail
Item #	Description	4/4M	3/4M	1/2M	
A311	E-tinned high-carbon steel	16.8	15.7	14.6	\$7.75
A312	A-aluminum	12.3	12	10.5	\$12.65
A313	D-monel	10	9.5	9	\$13.50
A314	G-monel	10	9.5	9	\$14.65
A310	Set coiled				\$46.00



Ascenté violin strings are a tremendous value and have set a new standard for beginner-level strings at a budget-friendly price. They offer the quality and craftsmanship that can help your students begin to produce a more sophisticated tone and make your young orchestras sound mature.

Dr. Charles Laux, Alpharetta High School



Pro-Arté™ Violin Strings

Pro-Arte Violin strings are crafted with a nylon core to have a warm, round tone. They are durable, break in quickly, and are stable in humidity and temperature changes. Pro-Arte strings are lower in tension in order to maximize bow response, tonal blend and playability. They are an exceptional choice for students and advancing players seeking a balanced string which complements a wide variety of instruments.

- Available in 4/4, 3/4, 1/2, 1/4, 1/8 (fits 1/10), and 1/16 size
- All complete sets and fractional size singles available in medium tension only
- J56W and J5601W available in 4/4 size only

Full Size		Tension		Retail
Item #	Description	4/4M		
J5601	E-tinned high-carbon steel	16.8		\$8.30
J5601W	E-aluminum wound	18.1		\$17.60
J5602	A-aluminum	12		\$20.70
J5603	D-aluminum	11.3		\$22.00
J5603S	D-silver	11.7		\$29.75
J5604	G-silver	10.6		\$26.15
J56	Set coiled (aluminum D)			\$76.05
J56W	Set coiled (aluminum E)			\$87.20

Fractional Sizes		Tension		Retail
Item #	Description	4/4M		
J5601	E-tinned high-carbon steel			\$8.00
J5602	A-aluminum			\$19.65
J5603	D-aluminum			\$20.70
J5604	G-silver			\$25.35
J56	Set coiled (aluminum D)			\$72.70



Prelude™ Violin Strings

An ideal choice for students and beginners, Prelude strings have a solid steel core, making them both durable and exceptionally stable in pitch. They are not affected by temperature and humidity changes. Due to a unique damping technique, Prelude strings are easy to bow and have the warmest sound of any solid steel core strings available.

- Available in 4/4, 3/4, 1/2, 1/4, 1/8 (fits 1/10), and 1/16 size
- 4/4 size available in light, medium, and heavy tension
- Fractional sizes available in medium tension only

Full Size		Tension			Retail
Item #	Description	4/4L	4/4M	4/4H	
J811	E-tinned high-carbon steel	16.8	18.6	20.4	\$6.45
J812	A-aluminum	12.2	13.1	14.1	\$10.60
J813	D-nickel	10.3	11.7	12.5	\$11.15
J814	G-nickel	10.3	11.4	13.2	\$11.65
J810	Set coiled				\$39.05

Fractional Sizes		Tension		Retail
Item #	Description	4/4M		
J811	E-tinned high-carbon steel			\$6.45
J812	A-aluminum			\$10.60
J813	D-nickel			\$11.15
J814	G-nickel			\$11.65
J810	Set coiled			\$39.05

Kaplan™ Amo, Kaplan Vivo, and Kaplan Forza Viola Strings



Kaplan Viola Strings now offer a full range of options designed to meet the exacting needs of professional-level players: we introduced two new synthetic core sets in 2016, Kaplan Amo and Kaplan Vivo, and our existing stranded-steel core set was renamed Kaplan Forza.

Kaplan Amo provides warmth, richness, and flexibility for brighter instruments, while Kaplan Vivo delivers brilliance, clarity, and a robust feel for darker instruments. The synthetic core and unique winding technology of the Amo and Vivo sets produce a beautifully textured tone. Kaplan Forza, the stranded steel core set, provides an even higher level of clarity and tonal focus, as well as quicker bow response and settling time.

- Kaplan Amo and Kaplan Vivo are available in long scale (16" and over); Kaplan Forza is available in long scale (16" and over), medium scale (15"-16") and short scale (14"-15")
- Long scale available in medium and heavy tension
- K411 LM also available in light tension

Kaplan Amo Standard Long Scale

Item #	Description	Tension		Retail
		LM	LH	
KA411	A-La solid steel/titanium	18.5	19.6	\$47.70
KA412	D-Ré silver wound	12.8	14.0	\$49.75
KA413	G-Sol silver wound	13.0	14.0	\$55.40
KA414	C-Do tungsten-silver wound	13.0	14.5	\$62.80
KA410	Set coiled			\$214.35

Kaplan Vivo Standard Long Scale

Item #	Description	Tension		Retail
		LM	LH	
KV411	A-La solid steel/titanium	18.5	19.6	\$47.70
KV412	D-Ré silver wound	12.8	14.0	\$49.75
KV413	G-Sol silver wound	13.0	14.0	\$55.40
KV414	C-Do tungsten-silver wound	14.0	14.5	\$62.80
KV410	Set coiled			\$214.35

Kaplan Forza Standard Long Scale

Item #	Description	Tension			Retail
		LL	LM	LH	
K411	A-solid steel/titanium	16.4	18.5	19.6	\$47.70
K412	D-stranded steel/aluminum		12.8	13.7	\$49.75
K413	G-stranded steel/silver		13.0	14.0	\$55.40
K414	C-stranded steel/tungsten & silver		14.0	15.0	\$62.80
K410	Set coiled				\$214.35

Kaplan Forza Fractional Sizes

Item #	Description	Retail
K411	A-solid steel/aluminum	\$47.70
K412	D-stranded steel/aluminum	\$49.75
K413	G-stranded steel/silver	\$55.40
K414	C-stranded steel/tungsten & silver	\$62.80
K410	Set coiled	\$214.35



Kaplan Solutions™ Viola A String

Designed to add power and projection in high registers, the Kaplan Solutions Viola A produces a bright and open sound and can sustain extreme bow weight.

- Available in long scale (16" and over) only
- Available in medium tension only

Item #	Description	Tension		Retail
		LM		
KS411 LM	A-solid steel/titanium	18.0		\$30.25



Zyex® Viola Strings

Zyex Viola Strings have been designed for the most demanding musicians. They are crafted with a highly refined Zyex synthetic core material, giving them a balanced, rich sound. String tensions have been optimized for the best bow response. The Zyex core provides each string with pitch stability, and fast break-in time. Zyex strings work well on both modern and brighter-sounding instruments.

- Available in long scale (16" and over), medium scale (15-16"), and short scale (14-15")
- Long scale (16" and over) available in medium and heavy tension, and in light tension singles
- Medium and short scale available in medium tension only

Standard Long Scale

Item #	Description	Tension		Retail
		LM	LH	
DZ411	A-aluminum	15.9	18.5	\$25.35
DZ412A	D-aluminum	11.8	13.4	\$28.70
DZ413	G-silver	11.8	13.8	\$35.95
DZ414	C-tungsten/silver	11.4	12.9	\$42.15
DZ410	Set coiled			\$130.40

Fractional Sizes

Item #	Description	Retail
DZ411	A-aluminum	\$23.80
DZ412	D-aluminum	\$26.90
DZ412A	D-aluminum	\$26.90
DZ413	G-silver	\$34.15
DZ414	C-tungsten/silver	\$40.10
DZ410	Set coiled	\$124.70



VIOLA STRINGS



Helicore™ Viola Strings

Helicore multi-stranded steel core strings produce a warm and clear sound, with excellent pitch stability and short break-in time. They have a small diameter, allowing comfortable playability and quick bow response. A high E string is also available.

- Available in extra long scale (17" and over), long scale (16" and over), medium scale (15"-16"), and short scale (14"-15")
- Long scale (16" and over) available in light, medium, and heavy tension, medium and short scale available in medium tension only
- H415 available in long scale (16" and over) single string only

Standard Long and Extra Long Scale

Item #	Description	Tension			Retail
		LL	LM	LH	
H411	A-aluminum	15.6	17.0	18.2	\$24.75
H412	D-titanium	11.3	12.8	14.2	\$29.25
H413	G-silver	11.9	13.8	15.0	\$31.25
H414	C-tungsten/silver	11.8	13.1	14.6	\$38.00
H415	E-tinned high-carbon steel	20.4	22.5	25.0	\$20.25
H410	Set coiled (4-string)				\$119.75

Fractional Sizes

Item #	Description	Retail
H411	A-aluminum	\$23.75
H412	D-titanium	\$28.00
H413	G-silver	\$29.75
H414	C-tungsten/silver	\$36.00
H410	Set coiled (4-string)	\$114.50



Prelude™ Viola Strings

An ideal choice for students and beginners, Prelude strings have a solid steel core, making them both durable and exceptionally stable in pitch. They are not affected by temperature and humidity changes. Due to a unique damping technique, Prelude

strings are easy to bow and have the warmest sound of any solid steel core strings available.

- Available in long scale (16" and over), medium scale (15"-16"), short scale (14"-15"), and extra short scale (13"-14")
- Available in medium tension only

Standard Long Scale

Item #	Description	Tension	
		LM	Retail
J911	A-aluminum	16.1	\$14.75
J912	D-aluminum	11.6	\$15.00
J913	G-nickel	10.6	\$16.30
J914	C-nickel	10.8	\$17.60
J910	Set coiled		\$60.80

Fractional Sizes

Item #	Description	Retail
J911	A-aluminum	\$14.75
J912	D-aluminum	\$15.00
J913	G-nickel	\$16.30
J914	C-nickel	\$17.60
J910	Set coiled	\$60.80



Pro•Arte™ Viola Strings

Pro-Arte Viola Strings are crafted with a nylon core to have a warm, round tone. They are durable, break in quickly, and are stable in humidity and temperature changes. Pro-Arte strings are lower in tension in order to maximize bow response, tonal blend and playability.

They are an exceptional choice for students and advancing players seeking a balanced string which complements a wide variety of instruments.

- Available in long scale (16" and over), medium scale (15"-16"), and short scale (14"-15")
- Available in medium tension only
- J5802S available as single long scale (16" and over) only

Standard Long Scale

Item #	Description	Tension	
		LM	Retail
J5801	A-aluminum	15.1	\$24.05
J5802	D-aluminum	11.9	\$25.10
J5802S	D-silver	12.4	\$29.75
J5803	G-silver	11.5	\$28.45
J5804	C-silver	11.5	\$42.95
J58	Set coiled (aluminum D)		\$117.45

Fractional Sizes

Item #	Description	Retail
J5801	A-aluminum	\$23.05
J5802	D-aluminum	\$23.55
J5803	G-silver	\$27.15
J5804	C-silver	\$41.15
J58	Set coiled (aluminum D)	\$108.75



NS Electric Viola Strings

The set consists of regular-tuning strings (A, D, G, C). Additional 5th string, a high E, is available as a single.

Item #	Description	Tension	Retail
NS411	A	17.0	\$22.05
NS412	D	12.8	\$26.00
NS413	G	13.8	\$27.65
NS414	C	13.1	\$33.80
NS415	High E	22.5	\$17.90
NS410	Set		\$107.00



Kaplan™ Cello Strings

The Kaplan Cello Set is aimed at the most discerning musician. Its construction allows for heavy bow weight without losing sound clarity in the softest dynamics. The Kaplan cello set sounds warm and complex, and offers generous projection. The tension

is well-balanced throughout the set.

- Available in 4/4 size only
- Available in light, medium, and heavy tension

Full Size Item #	Description	Tension			Retail
		4/4L	4/4M	4/4H	
KS511	A-solid steel/titanium	35.2	39.0	41.1	\$59.50
KS512	D-solid steel/nickel	28.2	31.0	33.1	\$64.10
KS513	G-stranded steel/tungsten	29.0	30.9	32.3	\$111.00
KS514	C-stranded steel/tungsten	28.4	30.0	31.1	\$146.15
KS510	Set coiled				\$380.50



Helicore™ Cello Strings

Aimed at advanced and professional players, Helicore multi-stranded steel core strings produce a warm and clear sound, with excellent pitch stability and short break-in time. They have a small diameter, allowing very comfortable play and quick bow response.

Available in several fractional sizes for advancing young cellists. A high E string is also available.

- Available in 4/4, 3/4, 1/2, 1/4, and 1/8 size
- 4/4 size sets available in light, medium, and heavy tension
- Fractional sizes available in medium tension only
- H515 available as single medium tension string only

Full Size Item #	Description	Tension			Retail
		4/4L	4/4M	4/4H	
H511	A-titanium	33.3	35.6	38.1	\$42.25
H512	D-titanium	29.0	32.0	34.2	\$44.75
H513	G-tungsten/silver	27.4	29.4	31.7	\$94.50
H514	C-tungsten/silver	27.0	28.8	31.8	\$117.00
H515	E-aluminum		42.7		\$56.75
H510	Set coiled				\$292.30

Fractional Sizes

Item #	Description	Retail
H511	A-titanium	\$38.25
H512	D-titanium	\$41.25
H513	G-tungsten/nickel	\$82.75
H514	C-tungsten/nickel	\$103.00
H510	Set coiled	\$260.30



I switched to the Kaplan medium tension strings recently and have been very happy with how they sound. They are smooth and even and give me the projection I need. They are a great set of strings.

Brandon Vamos



Helicore™ Cello Fourths-Tuning Strings

The Helicore Cello Fourths-Tuning Set is designed to be tuned one octave above bass tuning (E, A, D, G - low to high). This tuning pattern allows for new chordal and scalar possibilities in alternative cello playing.

Like other Helicore strings, this set provides quick bow response and short settling time. Tonally, the set is rich and powerful, providing clarity and balance across the strings.

- Available in 4/4 size only
- Available in medium tension only

Full Size Item #	Description	Tension		Retail
		4/4M		
H551	G-stranded steel core/stainless steel	39.0		\$42.25
H552	D-stranded steel core/stainless steel	33.0		\$44.75
H553	A-stranded steel core/stainless steel	33.4		\$94.50
H554	E-stranded steel core/stainless steel	30.0		\$117.00
H550	Set coiled			\$292.30



Prelude™ Cello Strings

An ideal choice for students and beginners, Prelude strings have a solid steel core, making them both durable and exceptionally stable in pitch. They are not affected by temperature and humidity changes. Due to a unique damping technique, Prelude

strings are easy to bow and have the warmest sound of any solid steel core strings available.

- Available in 4/4, 3/4, 1/2, 1/4, and 1/8 size
- Medium tension only

Full Size Item #	Description	Tension		Retail
		4/4M		
J1011	A-nickel	36.5		\$28.70
J1012	D-nickel	30.0		\$30.80
J1013	G-nickel	29.0		\$33.40
J1014	C-nickel	28.0		\$36.75
J1010	Set coiled (nickel A)			\$126.00

Fractional Sizes

Item #	Description	Retail
J1011	A-nickel	\$28.70
J1012	D-nickel	\$30.80
J1013	G-nickel	\$33.40
J1014	C-nickel	\$36.75
J1010	Set coiled (nickel A)	\$126.00

CELLO & BASS STRINGS



Pro-Arté™ Cello Strings

Pro-Arte Cello Strings are crafted with a nylon core to have a warm, round tone. They are durable, break in quickly, and are stable in humidity and temperature changes. Pro-Arte strings are lower in tension in order to maximize bow response, tonal blend and playability.

They are an exceptional choice for students and advancing players seeking a balanced string which complements a wide variety of instruments.

- Available in 4/4, 3/4, 1/2, and 1/4 size
- Available in medium tension only
- J5903T available as 4/4 size medium tension single string only

Full Size	Item #	Description	Tension 4/4M	Retail
	J5901	A-aluminum	32.8	\$38.05
	J5902	D-silver	30.6	\$48.15
	J5903	G-silver	29.3	\$59.75
	J5903T	G-tungsten/silver	28.1	\$80.20
	J5904	C-tungsten/silver	27.7	\$90.80
	J59	Set coiled (silver G)		\$232.35

Fractional Sizes	Item #	Description	Retail
	J5901	A-aluminum	\$38.05
	J5902	D-silver	\$48.15
	J5903	G-silver	\$59.75
	J5904	C-tungsten/silver	\$90.80
	J59	Set coiled (silver G)	\$232.35



NS Electric Cello Strings

The set consists of regular tuning strings (A, D, G, C). Additional 5th and 6th strings, a high E and a low F, are available as singles.

Item #	Description	Tension	Retail
NS511	A	35.6	\$37.45
NS512	D	32.0	\$39.95
NS513	G	29.4	\$84.35
NS514	C	28.8	\$104.50
NS515	High E	42.7	\$50.55
NS516	Low F	27.0	\$104.50
NS510	Set		\$260.95



D'Addario, in partnership with Ned Steinberger, created NS Electric strings. Featuring great tone, quick bow response and pitch stability, NS Electric strings work well with many different varieties of pickups and playing styles.

Ned Steinberger and Jim D'Addario



NS Electric Bass Cello Strings

The NS Electric Bass Cello (or Omni Bass) strings are made to fit all standard 34"-35" scale bass guitars. They are polished smooth with rich bass tone and a clear, singing upper register. Additional 5th and 6th strings, a high C and a low B, are available as singles.

Item #	Description	Tension	Retail
NS711	G	35.4	\$38.00
NS712	D	36.0	\$40.50
NS713	A	35.5	\$86.35
NS714	E	35.5	\$104.75
NS715	High C	36.0	\$38.00
NS716	Low B	31.3	\$104.75
NS710	Set		\$269.60



NS Electric Traditional Bass Strings

The NS Electric Traditional Bass set is scaled to fit 3/4 size upright electric basses with shortened afterlengths. It is constructed and tensioned similarly to upright bass strings for a warm tone and great bow response. This set consists of standard tuning strings (G, D, A, E). Additional 5th and 6th strings, a low B and a high C, are available as singles.

Item #	Description	Tension	Retail
NS611	G	62.0	\$49.75
NS612	D	65.9	\$65.65
NS613	A	67.0	\$74.85
NS614	E	68.0	\$87.75
NS616	Low B	69.6	\$87.75
NS617	High C	52.5	\$46.10
NS610	Set		\$286.65

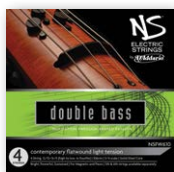

NS Electric Contemporary Bass Strings

The NS Electric Contemporary Bass set is scaled to fit 3/4 size upright electric basses with shortened afterlengths. It produces a brighter sound with lower tension than the Traditional Bass set. This set consists of standard tuning strings (G, D, A, E). Additional 5th and 6th strings, a low B and a high C, are available as singles.

Item #	Description	Tension	Retail
NSFW611	NS Electric Contemporary Bass G	58.0	\$49.75
NSFW612	NS Electric Contemporary Bass D	58.0	\$65.65
NSFW613	NS Electric Contemporary Bass A	50.7	\$74.85
NSFW614	NS Electric Contemporary Bass E	48.5	\$87.75
NSFW616	NS Electric Contemporary Bass Low B	49.0	\$87.75
NSFW617	NS Electric Contemporary Bass High C	52.5	\$46.10
NSFW610	NS Electric Contemporary Bass Set		\$286.65



Kaplan™ Double Bass Strings

The Kaplan Double Bass Set has been created to satisfy the needs of the most demanding orchestral players. It provides a rich, complex tone with incredible playability, for both left-hand ease and bow response. The set allows expressiveness and clarity while maintaining well-

balanced tension and tonal range across the set.

- Available in 3/4 size only
- Available in light, medium, and heavy tension
- K615 available as single string only

Full Size Item #	Description	Tension			Retail
		3/4L	3/4M	3/4H	
K611	G-titanium	58.0	62.0	65.0	\$87.70
K612	D-nickel	61.0	65.0	68.0	\$98.20
K613	A-nickel	63.0	68.0	72.0	\$112.05
K614	E-tungsten	65.0	69.0	73.0	\$133.05
K615	C-(Ext. E) tungsten	65.0	69.0	73.0	\$156.40
K610	Set coiled				\$427.90



NEW! Kaplan™ Solo Bass Strings

Kaplan Solo Bass Strings allow for solo-tuning playing with the rich and complex tone of Kaplan Orchestral bass strings. Designed for the solo/orchestral player in A-E-B-F# tuning, these stranded-steel core strings have wonderful bow response and clarity, allowing for expressive

playability and even, balanced tension.

- Available in 3/4 size only
- Available in medium tension only
- KS615 3/4M available as a single string only

Full Size Item #	Description	Tension		Retail
		3/4M	3/4H	
KS611	A-stranded steel/nickel	71.0		\$87.70
KS612	E-stranded steel/nickel	74.0		\$98.20
KS613	B-stranded steel/nickel	76.0		\$112.05
KS614	F#-stranded steel/nickel	78.0		\$133.05
KS615	D-(Ext. F#) stranded steel/nickel	78.0		\$156.40
KS610	Set coiled			\$427.90



D'Addario has a great selection of upright bass strings for playing in different styles and settings. Each one is designed to work best in its own setting, but all are versatile, full-sounding strings.

Bridget Kearney



D'Addario strings give me the flexibility to perform in many different types of ensembles across many genres. On stage, in the studio, upright, electric, arco, pizz...it doesn't matter, there's a set of D'Addario strings that gets the job done.

Daniel Kimbro



After having tried numerous manufactured metal strings over a period of 50 years, I found that the D'Addario Helicore strings came closest to my ideal. I love the way they sound and handle.

Gary Karr



Zyex® Bass Strings

Zyex Bass Strings use a Zyex synthetic core that provides gut-like, rich, and complex tone, combined with power and clarity for both pizzicato and bowing. Pitch stability is excellent after minimal break-in time. A 4/4 E string is available to accommodate basses with longer overall lengths. Standard 3/4 A, D, and G strings will complement the 4/4 string.

- Available in 3/4 size only
- Available in light and medium tension
- DZ615 and DZ614 4/4 size available as single strings only

Full Size Item #	Description	Tension		
		3/4L	3/4M	Retail
DZ611	G-titanium	58.0	61.0	\$83.55
DZ612	D-nickel	59.5	62.5	\$93.15
DZ613	A-tungsten	62.5	64.5	\$106.85
DZ614	E-tungsten	64.0	66.0	\$124.95
DZ615	C-(Ext. E) tungsten	64.0	66.0	\$150.60
DZ610	Set coiled			\$407.75

Item #	Description	4/4L	4/4M	Retail
DZ614 4/4	E-tungsten	64.5	66.0	\$124.95

BASS STRINGS



Helicore™ Orchestra Bass Strings

Designed for the artist who plays primarily arco. A multi-stranded core allows exceptional bow response and even tonal balance from string to string. Can be played pizzicato with full fundamental tone and warm harmonics.

- Available in 3/4, 1/2, 1/4, 1/8, and 1/10 (fits 1/16) size
- 3/4 size available in light, medium, and heavy tensions
- Fractional sizes available in medium tension only
- H615 and H616 available as 3/4 size, medium tension, single strings only

Full Size Item #	Description	Tension			Retail
		3/4L	3/4M	3/4H	
H611	G-nickel	58.2	62.0	64.0	\$66.00
H612	D-nickel	61.3	65.9	68.4	\$73.75
H613	A-nickel	62.5	69.0	73.0	\$84.00
H614	E-nickel	64.1	70.0	74.8	\$98.25
H615	C-(Ext. E) nickel		70.0		\$111.00
H616	Low B-nickel		66.4		\$116.25
H610	Set coiled				\$321.30

Fractional Sizes

Item #	Description	Retail
H611	G-nickel	\$55.75
H612	D-nickel	\$64.00
H613	A-nickel	\$81.75
H614	E-nickel	\$94.25
H610	Set coiled	\$290.30



Helicore™ Hybrid Bass Strings

Designed for the player who performs both arco and pizzicato. Excellent pizzicato sustain and attack. A multi-stranded core allows quick, accurate bow response. A universal choice for a broad range of musical styles.

- Available in 3/4 and 1/2 size
- 3/4 size available in light, medium, and heavy tensions; 1/2 size available in medium tension only
- HH616 available in medium tension only
- HH615 and HH616 available as 3/4 size single strings only

Full Size Item #	Description	Tension			Retail
		3/4L	3/4M	3/4H	
HH611	G-nickel	58.2	62.0	64.0	\$66.00
HH612	D-nickel	61.3	64.5	68.4	\$73.75
HH613	A-nickel	63.0	67.0	70.0	\$84.00
HH614	E-nickel	64.0	68.0	71.0	\$98.25
HH615	C-(Ext. E) nickel		68.0		\$111.00
HH616	Low B-nickel		69.6		\$116.25
HH610	Set coiled				\$321.30

Fractional Sizes

Item #	Description	Retail
HH611	G-nickel	\$55.75
HH612	D-nickel	\$64.00
HH613	A-nickel	\$81.75
HH614	E-nickel	\$94.25
HH610	Set coiled	\$290.30

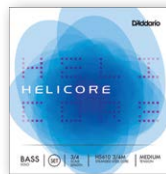

Helicore™ Solo Bass Strings

Designed for the solo/orchestral player in A-E-B-F# tuning. A multi-stranded core allows exceptional bow response and a warm, even tonal balance from string to string.

- Available in 3/4 size only
- Available in medium tension only

Full Size Item #	Description	Tension	
		3/4M	Retail
HS611	A-nickel	60.5	\$66.00
HS612	E-nickel	63.0	\$73.75
HS613	B-nickel	68.4	\$84.00
HS614	F#-nickel	69.0	\$98.25
HS610	Set coiled		\$321.30

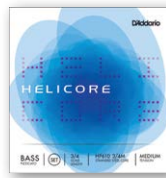

Helicore™ Pizzicato Bass Strings

Designed for the player who primarily performs pizzicato for a bright attack with excellent sustain.

- Available in 3/4 size only
- Available in light, medium, and heavy tension
- HP615 available as single string only

Full Size Item #	Description	Tension			Retail
		3/4L	3/4M	3/4H	
HP611	G-nickel	58.2	62.0	64.0	\$66.00
HP612	D-nickel	61.0	66.0	69.0	\$73.75
HP613	A-nickel	63.0	67.0	70.0	\$84.00
HP614	E-nickel	64.0	68.0	71.0	\$98.25
HP615	C-(Ext. E) nickel		68.0		\$111.00
HP610	Set coiled				\$321.30



Prelude™ Bass Strings

Prelude Bass Strings are designed to fulfill the need for an easily playable yet economical string for students. They are crafted with a special stranded steel core designed to provide optimum playability and tension for developing bassists.

- Available in 3/4, 1/2, 1/4, and 1/8 size
- Available in medium tension only
- Octave-tuned strings available for 1/16 and 1/32 size in bulk only

Full Size Item #	Description	Tension	
		3/4M	Retail
J611	G-stainless steel	61.5	\$39.35
J612	D-stainless steel	65.4	\$42.95
J613	A-stainless steel	68.5	\$52.25
J614	E-stainless steel	69.5	\$59.75
J610	Set coiled		\$192.50

Fractional Sizes

Item #	Description	Retail
J611	G-stainless steel	\$39.35
J612	D-stainless steel	\$42.95
J613	A-stainless steel	\$52.25
J614	E-stainless steel	\$59.75
J610	Set coiled	\$192.50



D'Addario Natural Rosin

All natural ingredients combined in a unique process make it perfect for either horsehair or synthetic-hair bows. Handsome packaging fits nicely in instrument cases and the unique plastic channel provides an easy grip for students. Each display holds 12 individual rosins. Sold in packers of 12 and cases of 72.

Item #	Description	Retail
VR200	Light	\$6.70
VR300	Dark	\$6.70



Kaplan™ Premium Rosin with Case

Kaplan Premium Rosin is formulated using the original Kaplan recipe, which produces less dust, helping to keep the instrument cleaner. The rosin is packed in an attractive case, designed for easy one-handed use, and has a dial on the bottom to ensure even wear. Sold in packers of 5 and cases of 30.

Item #	Description	Retail
KRDL	Light	\$16.90
KRDD	Dark	\$16.90



Kaplan™ Artcraft Rosin

Premium-quality Kaplan Artcraft Rosin is crafted using the original recipe handed down from Ladislav Kaplan. It is packaged in a reusable soft flannel pouch. Each display holds 12 individual rosins. Sold in packers of 12 and cases of 72.

Item #	Description	Retail
KACR6	Light	\$12.30
KACR7	Dark	\$12.30



Kaplan™ Rosin Display Box

The Kaplan Rosin Display Box is filled with 12 Kaplan Premium rosins with a choice of Light or Dark. Refills of 12 rosins in bulk (no individual packaging) are also available for the same price. The Kaplan Rosin Display Box has been designed to highlight the unique features of the Kaplan premium rosin.

- Side brackets to allow one-handed opening
- Rotating bottom dial to ensure even wear
- Elegant case provides full rosin protection

Item #	Description	Retail
KRDLBX	Box with 12 Premium Light rosins	\$202.80
KRDDBX	Box filled with 12 Premium Dark rosins	\$202.80
YBKRD	Refill of 12 Kaplan Light rosins	\$202.80
YBKRDD	Refill of 12 Kaplan Dark rosins	\$202.80

Kaplan Premium Light and Dark rosins are available in their individual packaging (KRDL and KRDD).



Kaplan™ Ball End Adapter

The Kaplan Ball End Adapter allows ball end violin and viola strings to be used with loop end hook-type fine tuners. With its gold finish, it is small and discreet. It also preserves the alignment of the string from tuner to bridge. Each package contains 5 adapters.

Item #	Retail
KSAA	\$9.20

DISPLAYS



Single String Wooden Bins

Item #	Description
SRGE5	Empty wooden box for single violin and viola strings
SRBE3	Empty wooden box for single cello strings
SRGE	Cards
SRBE	Cards



HBVSD

GDE3

BDE2-L

String Displays

These attractive displays will fit on slatwall or sit on a countertop. (shown with product)

Item #	Description
HBVSD	Empty Bass String Display (holds 5 sets)
BDE2-L	D'Addario Spring-loaded Display – Cello 7" L x 7" W x 14" H
GDE3	D'Addario Spring-loaded Display – Violin, Viola 7" L x 5" W x 11" H



D'Addario Brochure Rack

This wire frame holder attaches neatly onto any slatwall, EVUMS or JRUMS fixture and will fit any of our branded gear or survival guide brochures.

Item # DD-WLH

INSTRUMENT CARE



Humiditrak™

Musical instruments can be easily damaged by large and rapid changes in humidity and temperature. Now you can protect your investments by simply placing D'Addario's Humiditrak with Blustream Technology™ inside your instrument or case. Humiditrak uses a patent-pending Bluetooth sensor to provide a constant stream of temperature, humidity, and impact data to the free smartphone app to alert you of hazardous conditions that can lead to diminished playability, costly repairs, and lost value to your instrument. When Humiditrak detects dangerous conditions, push notifications are sent to your device, allowing you to take corrective action before damage occurs. Cataloging and monitoring a collection of instruments is so easy and convenient, you'll want one for every instrument you own!

- iOS/Android instrument monitoring
- Hourly, daily & monthly data tracking
- Easily installs within instrument or case
- Automatic push notifications of hazardous conditions



**FREE
SMART-
PHONE
APP**

Item #	Retail
PW-HTK-01	\$87.45



Humidity & Temperature Sensor

The D'Addario Humidity & Temperature Sensor (HTS) will help monitor your instrument's climatic conditions to avoid damage and costly repairs.

- The precision-designed hygrometer digitally indicates accurate Relative Humidity level
- Temperature is displayed in either Fahrenheit or Celsius
- Includes memory of highest and lowest readings with date and time stamp

Item #	Description	Retail
PW-HTS	Humidity & Temperature Sensor	\$45.55



TOP★SELLER

Humidipak: Two-Way Humidification System

D'Addario brings you Boveda's® patented technology as part of our instrument care line. Boveda is the first two-way humidity control that maintains a constant 45-50% Relative Humidity level inside your instrument case. The patented Two-Way Humidification System completely eliminates all the guesswork and anxiety of maintaining your instrument's proper humidity level. No more guessing if or when to refill the humidifier and worrying about drips or mess. No more manual adjustments based on seasonal changes, geographic locations, temperature, or other factors. Unlike all refillable humidifiers, this humidification system provides true two-way purified humidity control since it adds or depletes moisture only as needed to maintain 45-50% RH – the ideal climate for wooden instruments.

Item #	Description	Retail
PW-HPK-01	Humidipak Maintain Kit	\$45.35
PW-HPRP-03	Standard Refill Packet - 3-pack	\$29.25
PW-HPRP-12	Standard Refill Packet - 12-pack	\$101.85

Boveda's technology is protected by one or more of the following patents: 5936178, 2298597, 1064644, 6921026, 6244432, 8748723.



Small Instrument Humidifier

The Small Instrument Humidifier releases moisture evenly and slowly inside your instrument's case to maintain the proper humidity level, preventing cracks, warping, and shrinkage. Using the humidifier is as easy as moistening the sponge when it becomes dry. Get one for all of your valuable instruments. It's the smart, easy, and affordable way to protect your investments.

- Small size fits in any case
- Ideal for smaller acoustic, orchestral, and woodwind instruments
- Releases moisture slowly and evenly
- Safe for all instruments

Item #	Retail
PW-SIH-01	\$11.65

NS Micro Violin Tuner

The NS Micro Violin Tuner features an easy-to-read multi-color display and metronome in an attractive, compact design. A non-marring lever-lock clamp holds the tuner securely to the instrument, while allowing easy application and removal. The precision violin tuner is not only perfect for tuning, the unique mounting system and fast pitch response allow it to be used as an effective practice tool for referencing and improving intonation while playing.

- Easy-to-use lever-lock clamp
- Visual metronome
- Reversible multi-color display
- Wide calibration range (410 - 480 Hz)
- Perfect for tuning and practicing

Item #	Retail
PW-CT-14	\$37.30

US Patent #D703263



Pacato Hearing Protection

D'Addario Pacato Hearing Protection is a reusable, universal-sized audio filter designed specifically for musicians and music enthusiasts. While other hearing protection can sound muffled and unnatural, Pacato filters provide full frequency and enjoyable audio at safe listening levels. The exclusive design offers an open air passage to the ear, minimizing occlusion effects (low frequency emphasis) while keeping the ear ventilated for unmatched comfort.

- Provides a noise reduction rating of 19dB
- Includes large and small earplugs, lanyard, and carrying case

Item #	Retail
PWPEP1	\$43.15

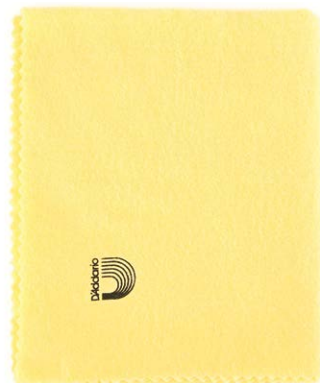

Untreated Polishing Cloth

Made from high-quality, double-napped cotton flannel, D'Addario Polishing Cloths pick up dust and dirt more effectively than ordinary polishing cloths and last longer.

Item #	Retail
PWPC2	\$8.75



Comfort Fit Ear Plugs

D'Addario Comfort Fit Ear Plugs are made from slow recovery PVC foam, and provide a noise reduction rating of 29 db.

Item #	Description	Retail
PWEPI	1 pair	\$2.65
PWEP3	3 pairs	\$7.05
PWEP100	100 pairs in fish bowl	\$209.35

MUSIC PAPER

Archives music manuscript paper is the finest quality paper available. Archives utilizes the same type of acid-free, balanced pH paper used by the Library of Congress, ensuring your compositions will look their best and last a long time. With the wide variety of book sizes and stave choices, you are sure to find just the right format for your music. Free display box included when you order in packer quantities!



Loose Leaf Sheets

Fifty 8 1/2" x 11" loose leaf sheets, 3-hole punched and packed in individual packs. LL8S, LL10S and LL12S are printed on 24 lb eggshell ledger stock. X8S, X10S, and X12S are printed on pure white stock for xerographic purposes.

Item #	Packer Qty	Description	Retail
LL8S	10	8 stave - 50 sheets	\$7.80
LL10S	10	10 stave - 50 sheets	\$7.80
LL12S	10	12 stave - 50 sheets	\$7.80
X8S	10	8 stave - 50 xerographic sheets	\$6.70
X10S	10	10 stave - 50 xerographic sheets	\$6.70
X12S	10	12 stave - 50 xerographic sheets	\$6.70



Double-Folded Sheets

Twenty four 12 1/2" x 19" sheets printed on both sides on 28lb eggshell smooth ledger stock and folded to 9 1/2" x 12 1/2". Packed 24 sheets per pack.

Item #	Packer Qty	Description	Retail
D8S	10	8 stave - 24 sheets	\$9.50
D10S	10	10 stave - 24 sheets	\$9.50
D12S	10	12 stave - 24 sheets	\$9.50



Standard Bound Books

Quality Archives paper-stitched, folded, and perforated for easy sheet removal.

Item #	Packer Qty	Description	Retail
GTAB-48ST	20	Guitar Tab - 48 sheets	\$8.40
B10S-48ST	20	10 stave - 48 sheets	\$7.25
B12S-48ST	20	12 stave - 48 sheets	\$7.25
B6S-64ST	25	6 stave - 64 sheets/title	\$7.25



Spiral-Bound Books

Spiral wire-bound books all have sturdy leathertone covers with the same high-quality Archives music paper inside.

Item #	Packer Qty	Description	Retail
B6S-64*	25	6 stave, 64 pages, 7" x 8"	\$6.70
SB88S64	20	Double 8 stave, 64 pages, 11" x 13"	\$14.25
SB18S64	20	18 stave, 64 pages, 12" x 16"	\$15.10
B10S-48*	20	10 stave, 48 pages, 9" x 12"	\$7.80
B10S-96	10	10 stave, 96 pages, 9" x 12"	\$13.15
B12S-48*	20	12 stave, 48 pages, 9" x 12"	\$7.80
B12S-96	10	12 stave, 96 pages, 9" x 12"	\$13.15

Custom Logos

Designated spiral-bound books can be ordered with your store logo printed on the front cover! Contact your D'Addario Sales representative for details and pricing.



Manuscript Pads

The same great Archives paper and printing quality in pad form. Four models, all 50 sheets per pad. Printed on one side only.

Item #	Packer Qty	Description	Retail
SL8S	10	8 stave score pad - 50 sheets	\$8.40
SL10S	10	10 stave score pad - 50 sheets	\$8.40
SL12S	10	12 stave score pad - 50 sheets	\$8.40
SP18S	15	18 stave score pad - 50 sheets	\$15.10

WOODWINDS



A COMMITMENT TO INNOVATION

As we begin a new year, we reflect on our brand's accomplishments in 2017 and look forward to the exciting and innovative projects that will be completed in 2018.

We started off the year with the launch of an updated look and feel of two of our flagship brands: **Rico and Royal by D'Addario**. Trusted by educators for decades, today's Rico and Royal reeds not only look better than ever, but are also more consistent due to D'Addario's proprietary digital reed-making technology.



In 2017, we also introduced our first **Reserve reed for Eb clarinet**. With innovation at the core of every project, this reed was designed to emulate the feel of a Bb clarinet reed without needing to cut or modify a larger reed. The Reserve Eb Clarinet reed completes our Reserve line for clarinet, which also includes options for Bb and bass clarinets.

This past year also brought us the **Select Jazz mouthpiece for tenor saxophone**, modeled after the prized vintage hard rubber jazz tenor mouthpieces. The result of a collaboration with Dave Matthews Band saxophonist and D'Addario artist Jeff Coffin, as well as a host of other esteemed jazz tenor saxophonists, this mouthpiece has received an overwhelming amount of positive feedback from the market. It is the second offering in the Select Jazz line of mouthpieces.

In 2018, you can look forward to innovative product and packaging updates to our ligature, mouthpiece cap, and strap offerings. We will also welcome new clarinet and saxophone mouthpiece offerings. We look forward to finishing development on our long-awaited **Reserve Alto Saxophone mouthpiece**, which we are confident will challenge the current mouthpiece offerings for concert saxophonists everywhere.



We are committed to continuing to expand our product line with groundbreaking products that improve the experience of playing woodwind instruments for students, teachers, and professionals. We look forward to what this year will bring for us and for our customers. Much like the work done by your customers in the practice room, we are committed to daily improvement in every area of our brand.

TOP SELLERS & MUST HAVES



RICO CLARINET & ALTO SAXOPHONE REEDS

(see page 184)



ROYAL CLARINET & ALTO SAXOPHONE REEDS

(see page 185)



D'ADDARIO RESERVE CLASSIC B \flat CLARINET REEDS

(see page 186)



D'ADDARIO RESERVE B \flat CLARINET REEDS

(see page 186)

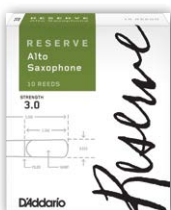

D'ADDARIO RESERVE ALTO SAXOPHONE REEDS

(see page 187)



RESERVE B \flat CLARINET MOUTHPIECES

(see page 191)



SELECT JAZZ ALTO SAXOPHONE MOUTHPIECES

(see 192)



SELECT JAZZ TENOR SAXOPHONE MOUTHPIECES

(see page 193)



MULTI-INSTRUMENT REED CASE

(see page 200)



D'ADDARIO REED GUARDS

(see page 201)

REEDS



TOP★SELLER Rico by D'Addario

Rico reeds are unfiled and feature a thinner profile and blank. Designed for ease of response, they are ideal for students, revered by educators worldwide, and are a favorite among jazz musicians. D'Addario's state-of-the-art machinery and reed-making process have resulted in unprecedented consistency in today's Rico reed.

- Updated presentation
- Priced affordably for educators
- Offered in 3-reed packs, boxes of 10 reeds, 25-reed Novapak dispensers
- Available for the full range of clarinets and saxophones in half strengths, from 1.5 to 4.0

	Eb Clarinet		Bb Clarinet			Alto Clarinet		Bass Clarinet			Contra Bass Clarinet/ Bass Sax
	Boxes of 10	Boxes of 25 (Dispenser)	3-Packs	Boxes of 10	Boxes of 25 (Dispenser)	3-Packs	Boxes of 10	3-Packs	Boxes of 10	Boxes of 25 (Dispenser)	Boxes of 10
Retail	\$38.00	\$90.75	\$11.00	\$32.75	\$78.00	\$14.75	\$47.75	\$20.25	\$61.00	\$148.00	\$94.50
1.5	RBA1015	RBA2515	RCA0315	RCA1015	RCA2515		RDA1015	REA0315	REA1015		RFA1015
2.0	RBA1020		RCA0320	RCA1020	RCA2520	RDA0320	RDA1020	REA0320	REA1020	REA2520	RFA1020
2.5	RBA1025		RCA0325	RCA1025	RCA2525	RDA0325	RDA1025	REA0325	REA1025	REA2525	RFA1025
3.0	RBA1030		RCA0330	RCA1030	RCA2530	RDA0330	RDA1030	REA0330	REA1030	REA2530	RFA1030
3.5	RBA1035		RCA0335	RCA1035	RCA2535		RDA1035		REA1035	REA2535	RFA1035
4.0				RCA1040					REA1040		

	Soprano Saxophone			Alto Saxophone		
	3-Packs	Boxes of 10	Boxes of 25 (Dispenser)	3-Packs	Boxes of 10	Boxes of 25 (Dispenser)
Retail	\$14.85	\$42.40	\$92.70	\$14.75	\$46.25	\$110.25
1.5	RIA0315	RIA1015	RIA2515	RJA0315	RJA1015	RJA2515
2.0	RIA0320	RIA1020	RIA2520	RJA0320	RJA1020	RJA2520
2.5	RIA0325	RIA1025	RIA2525	RJA0325	RJA1025	RJA2525
3.0	RIA0330	RIA1030	RIA2530	RJA0330	RJA1030	RJA2530
3.5		RIA1035	RIA2535	RJA0335	RJA1035	RJA2535
4.0		RIA1040			RJA1040	

	Tenor Saxophone			Baritone Saxophone		
	3-Packs	Boxes of 10	Boxes of 25 (Dispenser)	3-Packs	Boxes of 10	Boxes of 25 (Dispenser)
Retail	\$19.00	\$61.50	\$146.05	\$24.50	\$76.00	\$185.05
1.5	RKA0315	RKA1015	RKA2515	RLA0315	RLA1015	
2.0	RKA0320	RKA1020	RKA2520	RLA0320	RLA1020	RLA2520
2.5	RKA0325	RKA1025	RKA2525	RLA0325	RLA1025	RLA2525
3.0	RKA0330	RKA1030	RKA2530	RLA0330	RLA1030	RLA2530
3.5	RKA0335	RKA1035	RKA2535		RLA1035	RLA2535
4.0		RKA1040			RLA1040	

* Each reed is individually sealed and barcoded.



TOP★SELLER

Royal™ by D'Addario

Royal reeds are filed and feature a thinner profile and blank. They are ideal for students and advancing players, and are revered by educators worldwide. Royal reeds offer ease of response and increased clarity in the sound. D'Addario's state-of-the-art machinery and reed-making process have resulted in unprecedented consistency in today's Royal reed.

- Updated presentation
- Priced affordably for educators
- Offered in 3-reed packs and boxes of 10 reeds
- Available for a range of clarinet and saxophone voices in half strengths, from 1.0 to 4.0 and 5.0

	Eb Clarinet	Bb Clarinet	Alto Clarinet	Bass Clarinet	Soprano Saxophone	Alto Saxophone	Tenor Saxophone	Baritone Saxophone			
	Boxes of 10	3-Packs	Boxes of 10	Boxes of 10	Boxes of 10	Boxes of 10	3-Packs	Boxes of 10			
Retail	\$41.50	\$12.00	\$35.00	\$50.50	\$66.00	\$43.00	\$15.75	\$46.25	\$22.00	\$68.00	\$84.00
1.0	RBB1010		RCB1010					RJB1010		RKB1010	
1.5	RBB1015	RCB0315	RCB1015	RDB1015	REB1015	RIB1015	RJB0315	RJB1015	RKB0315	RKB1015	RLB1015
2.0	RBB1020	RCB0320	RCB1020	RDB1020	REB1020	RIB1020	RJB0320	RJB1020	RKB0320	RKB1020	RLB1020
2.5	RBB1025	RCB0325	RCB1025	RDB1025	REB1025	RIB1025	RJB0325	RJB1025	RKB0325	RKB1025	RLB1025
3.0	RBB1030	RCB0330	RCB1030	RDB1030	REB1030	RIB1030	RJB0330	RJB1030	RKB0330	RKB1030	RLB1030
3.5	RBB1035		RCB1035	RDB1035	REB1035	RIB1035		RJB1035		RKB1035	RLB1035
4.0	RBB1040		RCB1040	RDB1040	REB1040	RIB1040		RJB1040		RKB1040	RLB1040
5.0	RBB1050		RCB1050					RJB1050		RKB1050	RLB1050



Plasticover™ by D'Addario

Plasticover has a brilliant, projecting tone and creates a unique sound in various styles, from funk to Latin jazz. This coated reed is ideal for quick instrument changes and endures extreme weather conditions, making it the perfect solution for outdoor performances, too.

- Offered in boxes of 5
- Available for Soprano, Alto, Tenor, and Baritone saxophones and Bb Clarinet

	Bb Clarinet	Soprano Saxophone	Alto Saxophone	Tenor Saxophone	Baritone Saxophone
	Boxes of 5				
Retail	\$31.75	\$36.25	\$38.25	\$51.25	\$72.00
1	RRP05BCL100		RRP05ASX100		
1.5	RRP05BCL150	RRP05SSX150	RRP05ASX150	RRP05TSX150	RRP05BSX150
2	RRP05BCL200	RRP05SSX200	RRP05ASX200	RRP05TSX200	RRP05BSX200
2.5	RRP05BCL250	RRP05SSX250	RRP05ASX250	RRP05TSX250	RRP05BSX250
3	RRP05BCL300	RRP05SSX300	RRP05ASX300	RRP05TSX300	RRP05BSX300
3.5	RRP05BCL350	RRP05SSX350	RRP05ASX350	RRP05TSX350	RRP05BSX350
4	RRP05BCL400	RRP05SSX400	RRP05ASX400	RRP05TSX400	RRP05BSX400

REEDS

TOP★SELLER

D'Addario Reserve™

Each Reserve reed is made using D'Addario's digital vamping process, which precisely measures and cuts every reed to the tightest tolerances. This revolutionary process has marked the advent of a new era in reed manufacturing.

- Ideal for the advancing student and professional
- Crafted using the most innovative digital processes, yielding ultimate precision, quality, and consistency
- Available for Eb, Bb and Bass Clarinets and Soprano, Alto, Tenor, and Baritone Saxophones

visit daddario.com/reserve for the full story



D'Addario Reserve™ B \flat Clarinet

A traditional blank reed that features a **focused sound**, a shorter vamp for **evenness**, rounded tip corners for **tonal warmth**, and a standard tip thickness for **quick response**.

- Available in half strengths, from 2.0 to 4.5, with special 3.5+ and 4.0+ strengths

	Bb Clarinet	
	2-Packs	Boxes of 10
Retail	\$9.75	\$43.85
2.0	DCR0220	DCR1020
2.5	DCR0225	DCR1025
3.0	DCR0230	DCR1030
3.5	DCR0235	DCR1035
3.5+	DCR02355	DCR10355
4.0	DCR0240	DCR1040
4.0+	DCR02405	DCR10405
4.5	DCR0245	DCR1045

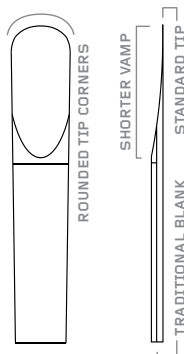

D'Addario Reserve™ Classic B \flat Clarinet

A thick blank reed that features **tonal depth**, a longer vamp for **flexibility**, squared tip corners for ease of **response**, and a thicker tip for **clear articulation**.

- Available in half strengths, from 2.0 to 4.5, with special 3.5+ and 4.0+ strengths

	Bb Clarinet	
	2-Packs	Boxes of 10
Retail	\$12.75	\$57.00
2.0	DCT0220	DCT1020
2.5	DCT0225	DCT1025
3.0	DCT0230	DCT1030
3.5	DCT0235	DCT1035
3.5+	DCT02355	DCT10355
4.0	DCT0240	DCT1040
4.0+	DCT02405	DCT10405
4.5	DCT0245	DCT1045

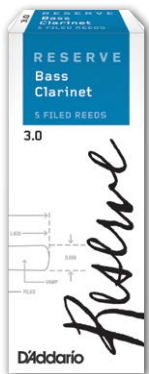
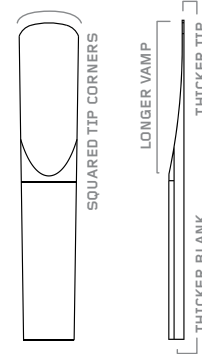

D'Addario Reserve™ Bass Clarinet

A thick blank, filed reed that offers great **projection**, featuring a medium tip thickness for **warmth** and core of sound, a traditional tip radius for **ease of response** and articulation, and a longer vamp for increased **tonal flexibility**.

- Available in half strengths, from 2.0 to 4.5, with special 3.0+ and 3.5+ strengths

	Bass Clarinet	
	Boxes of 5	
Retail	\$40.00	
2.0	DER0520	
2.5	DER0525	
3.0	DER0530	
3.0+	DER05305	
3.5	DER0535	
3.5+	DER05355	
4.0	DER0540	
4.5	DER0545	

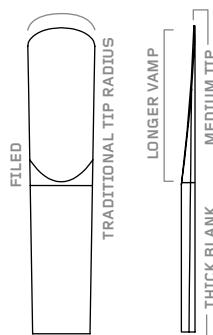

NEW! D'Addario Reserve™ E \flat Clarinet

A traditional blank, filed reed that features a longer vamp for **security of feel**, thick heart for **tonal depth and pitch stability**, flexible tip for **ease of response**, and squared tip corners for **exceptional articulation quality**.

- Designed to emulate the stability of a Bb clarinet reed, without needing to cut or modify a larger reed to fit the Eb clarinet
- Available in half strengths, from 2.0 to 4.5, with a special 3.5+ strength

	Eb Clarinet	
	Boxes of 10	
Retail	\$47.00	
2.0	DBR1020	
2.5	DBR1025	
3.0	DBR1030	
3.5	DBR1035	
3.5+	DBR10355	
4.0	DBR1040	
4.5	DBR1045	

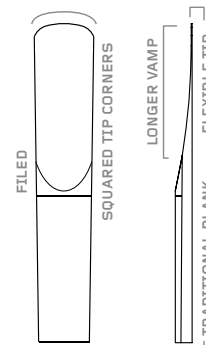



TOP★SELLER

D'Addario Reserve™ Saxophone

Premium, filed reeds that feature **tonal warmth**, a heavy spine for **dynamic flexibility** and **exceptional tone quality in all registers**, a long vamp profile for **consistency of response**, and a traditional tip thickness for **ease of articulation**.

- Available in half strengths, from 2.0 to 4.5, with a special 3.0+ strength

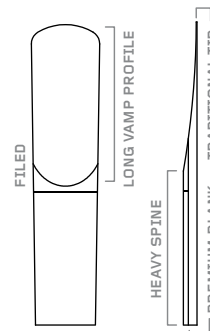

	Soprano Saxophone		Alto Saxophone		Tenor Saxophone		Baritone Saxophone	
	2-Packs	Boxes of 10	2-Packs	Boxes of 10	2-Packs	Boxes of 5	2-Packs	Boxes of 5
Retail	\$10.75	\$50.50	\$11.75	\$56.00	\$16.75	\$42.00	\$28.25	\$68.25
2.0	DIR0220	DIR1020	DJR0220	DJR1020	DKR0220	DKR0520	DLR0220	DLR0520
2.5	DIR0225	DIR1025	DJR0225	DJR1025	DKR0225	DKR0525	DLR0225	DLR0525
3.0	DIR0230	DIR1030	DJR0230	DJR1030	DKR0230	DKR0530	DLR0230	DLR0530
3.0+	DIR02305	DIR10305	DJR02305	DJR10305	DKR02305	DKR05305	DLR02305	DLR05305
3.5	DIR0235	DIR1035	DJR0235	DJR1035	DKR0235	DKR0535	DLR0235	DLR0535
4.0	DIR0240	DIR1040	DJR0240	DJR1040	DKR0240	DKR0540	DLR0240	DLR0540
4.5	DIR0245	DIR1045	DJR0245	DJR1045	DKR0245	DKR0545	DLR0245	DLR0545



D'Addario Reserve Sampler Packs

Reserve reed sampler packs allow the player to experiment with various strengths before committing to a full box. Each sampler pack contains an assortment of four individually-sealed reeds.

Item #	Instrument	Description	Retail
DRS-C25	Bb Clarinet	Reserve: 2.5, 3.0 Reserve Classic: 2.5, 3.0	\$21.00
DRS-C30	Bb Clarinet	Reserve: 3.0, 3.5 Reserve Classic: 3.0, 3.5	\$21.00
DRS-C35	Bb Clarinet	Reserve: 3.5, 3.5+ Reserve Classic: 3.5, 3.5+	\$21.00
DRS-C355	Bb Clarinet	Reserve: 3.5+, 4.0 Reserve Classic: 3.5+, 4.0	\$21.00
DRS-J25	Alto Saxophone	Reserve: 2.5, 3.0, 3.0, 3.0+	\$24.75
DRS-J30	Alto Saxophone	Reserve: 3.0, 3.0+, 3.0+, 3.5	\$24.75
DRS-K25	Tenor Saxophone	Reserve: 2.5, 3.0, 3.0, 3.0+	\$33.75
DRS-K30	Tenor Saxophone	Reserve: 3.0, 3.0+, 3.0+, 3.5	\$33.75



The consistent quality of the cane used and precision engineering make D'Addario Reserve reeds a pleasure to perform on.

Andrew Marriner, Principal Clarinet, London Symphony Orchestra



D'Addario Select Jazz™

Select Jazz reeds feature the thickest spine and blank of our jazz reeds, with a traditional tip shape. The Select Jazz cut offers great projection, focus, and a vibrant sound. They are available in both filed and unfiled models. They are offered in third strengths, rather than half strengths, so players can choose the most precise strength for their individual equipment. D'Addario's state-of-the-art machinery and reed-making process have resulted in unprecedented consistency in today's Select Jazz reeds.

- Outstanding control and projection
- Available in both filed and unfiled models for the full range of saxophones
- Available in third strengths (soft, medium, and hard) from 2.0 to 4.0

I never have to search long or hard to find a reed that sings right out of the box. Less time spent fussing with reeds means more time actually playing music.
Chris Potter,
International Jazz Soloist

visit daddario.com/selectjazz for more info

	Filed				Unfiled			
	Soprano Saxophone	Alto Saxophone	Tenor Saxophone	Baritone Saxophone	Soprano Saxophone	Alto Saxophone	Tenor Saxophone	Baritone Saxophone
	Boxes of 10		Boxes of 5		Boxes of 10		Boxes of 5	
Retail	\$50.50	\$56.00	\$42.00	\$68.25	\$50.50	\$56.00	\$42.00	\$68.25
2S	RSF10SSX2S	RSF10ASX2S	RSF05TSX2S	RSF05BSX2S	RRS10SSX2S	RRS10ASX2S	RRS05TSX2S	RRS05BSX2S
2M	RSF10SSX2M	RSF10ASX2M	RSF05TSX2M	RSF05BSX2M	RRS10SSX2M	RRS10ASX2M	RRS05TSX2M	RRS05BSX2M
2H	RSF10SSX2H	RSF10ASX2H	RSF05TSX2H	RSF05BSX2H	RRS10SSX2H	RRS10ASX2H	RRS05TSX2H	RRS05BSX2H
3S	RSF10SSX3S	RSF10ASX3S	RSF05TSX3S	RSF05BSX3S	RRS10SSX3S	RRS10ASX3S	RRS05TSX3S	RRS05BSX3S
3M	RSF10SSX3M	RSF10ASX3M	RSF05TSX3M	RSF05BSX3M	RRS10SSX3M	RRS10ASX3M	RRS05TSX3M	RRS05BSX3M
3H	RSF10SSX3H	RSF10ASX3H	RSF05TSX3H	RSF05BSX3H	RRS10SSX3H	RRS10ASX3H	RRS05TSX3H	RRS05BSX3H
4S	RSF10SSX4S	RSF10ASX4S	RSF05TSX4S	RSF05BSX4S	RRS10SSX4S	RRS10ASX4S	RRS05TSX4S	RRS05BSX4S
4M	RSF10SSX4M	RSF10ASX4M	RSF05TSX4M	RSF05BSX4M	RRS10SSX4M	RRS10ASX4M	RRS05TSX4M	RRS05BSX4M
4H	RSF10SSX4H	RSF10ASX4H	RSF05TSX4H	RSF05BSX4H	RRS10SSX4H	RRS10ASX4H	RRS05TSX4H	RRS05BSX4H

D'Addario Select Jazz Sampler Packs

Select Jazz reed sampler packs allow the player to experiment with various strengths before committing to a full box. Each saxophone sampler pack contains two Select Jazz reed strengths in both filed and unfiled cuts for a total of four reeds per card.

Item	Instrument	Description	Retail
DSJ-I2M	Soprano Saxophone	Filed: 2M, 2H Unfiled: 2M, 2H	\$20.00
DSJ-I3S	Soprano Saxophone	Filed: 3S, 3M Unfiled: 3S, 3M	\$20.00
DSJ-J2M	Alto Saxophone	Filed: 2M, 2H Unfiled: 2M, 2H	\$24.75
DSJ-J3S	Alto Saxophone	Filed: 3S, 3M Unfiled: 3S, 3M	\$24.75
DSJ-K2M	Tenor Saxophone	Filed: 2M, 2H Unfiled: 2M, 2H	\$33.75
DSJ-K3S	Tenor Saxophone	Filed: 3S, 3M Unfiled: 3S, 3M	\$33.75
DSJ-L2M	Baritone Saxophone	Filed: 2M, 2H Unfiled: 2M, 2H	\$59.75
DSJ-L3S	Baritone Saxophone	Filed: 3S, 3M Unfiled: 3S, 3M	\$59.75





La Voz™

La Voz reeds are unfiled and feature a thinner profile and blank. The powerful tone and flexibility offered by La Voz make this cut a standard among discerning jazz musicians. D'Addario's state-of-the-art machinery and reed-making process have resulted in unprecedented consistency in today's La Voz reed.

- Available for all saxophone voices and Bb/bass clarinets
- Offered in boxes of 10
- Available in strengths "soft" to "hard"

	Bb Clarinet	Bass Clarinet	Soprano Saxophone	Alto Saxophone	Tenor Saxophone	Baritone Saxophone
	Boxes of 10					
Retail	\$36.00	\$68.25	\$46.00	\$51.00	\$69.75	\$88.00
Soft	RCC10SF	REC10SF	RIC10SF	RJC10SF	RKC10SF	RLC10SF
Medium-Soft	RCC10MS	REC10MS	RIC10MS	RJC10MS	RKC10MS	RLC10MS
Medium	RCC10MD	REC10MD	RIC10MD	RJC10MD	RKC10MD	RLC10MD
Medium-Hard	RCC10MH	REC10MH	RIC10MH	RJC10MH	RKC10MH	RLC10MH
Hard	RCC10HD	REC10HD	RIC10HD	RJC10HD	RKC10HD	RLC10HD



Frederick L. Hemke™

Frederick L. Hemke reeds are filed and feature a thinner tip for ease of response, and a shorter vamp for a darker tone. They are a favorite among jazz musicians, classical musicians, and advancing students. D'Addario's state-of-the-art machinery and reed-making process have resulted in unprecedented consistency in today's Hemke reed.

- Shorter vamp for a dark tone
- Thinner tip for quick response and articulation
- Offered in boxes of 5
- Available in half strengths from 2.0 to 4.0 with a special 3.0+ strength (alto saxophone only)

	Soprano Saxophone	Alto Saxophone	Tenor Saxophone	Baritone Saxophone
	Boxes of 5			
Retail	\$23.75	\$26.50	\$35.75	\$46.00
2	RHHP5SSX200	RHHP5ASX200	RHHP5TSX200	RHHP5BSX200
2.5	RHHP5SSX250	RHHP5ASX250	RHHP5TSX250	RHHP5BSX250
3	RHHP5SSX300	RHHP5ASX300	RHHP5TSX300	RHHP5BSX300
3.0+		RHHP5ASX305		
3.5	RHHP5SSX350	RHHP5ASX350	RHHP5TSX350	RHHP5BSX350
4	RHHP5SSX400	RHHP5ASX400	RHHP5TSX400	RHHP5BSX400



Mitchell Lurie™

Ideal for the advancing student, Mitchell Lurie reeds feature a thinner tip for ease of response and a thicker spine for added resistance. D'Addario's state-of-the-art machinery and reed-making process have resulted in unprecedented consistency in today's Mitchell Lurie reed.

- Ideal for the advancing student
- Available in half strengths from 1.5 to 5.0

	Mitchell Lurie Bb Clarinet	Mitchell Lurie Premium Bb Clarinet
	Boxes of 10 (Unfiled)	Boxes of 5 (Filed)
Retail	\$36.50	\$22.75
1.5	RML10BCL150	RMLP5BCL150
2	RML10BCL200	RMLP5BCL200
2.5	RML10BCL250	RMLP5BCL250
3	RML10BCL300	RMLP5BCL300
3.5	RML10BCL350	RMLP5BCL350
4	RML10BCL400	RMLP5BCL400
4.5	RML10BCL450	RMLP5BCL450
5	RML10BCL500	RMLP5BCL500



My Mitchell Lurie reeds give me the support I need to produce powerful statements with my clarinet. Mitchell Lurie gives me the control and warm sound I desire.

Doreen "The Clarinet Queen" Kitchens, Renowned New Orleans Jazz Musician

REEDS



Grand Concert Select™

The Grand Concert Select line of reeds features a traditional tip for ease of response, combined with a thicker spine for added tonal depth and projection.

- Ideal for the advancing student and professional
- Thicker spine for added tonal depth and projection
- Offered in boxes of 10 for Eb/Bb clarinets and soprano/alto saxophones and boxes of 5 for bass clarinet and tenor/baritone saxophones



	Eb Clarinet	Traditional Blank Bb	Thick Blank Bb	Evolution Bb	Bass Clarinet	Soprano Saxophone	Alto Saxophone	Tenor Saxophone	Baritone Saxophone
	Boxes of 10				Boxes of 5	Boxes of 10		Boxes of 5	
Retail	\$46.00	\$46.50	\$47.50	\$57.00	\$39.50	\$46.75	\$53.00	\$38.00	\$52.50
2		RGC10BCL200	RGT10BCL200		RGB05SCL200				
2.5	RGC10ECL250	RGC10BCL250	RGT10BCL250	RGE10BCL250	RGB05SCL250	RGC10SSX250	RGC10ASX250	RGC05TSX250	RGC05BSX250
3	RGC10ECL300	RGC10BCL300	RGT10BCL300	RGE10BCL300	RGB05SCL300	RGC10SSX300	RGC10ASX300	RGC05TSX300	RGC05BSX300
3.5	RGC10ECL350	RGC10BCL350	RGT10BCL350	RGE10BCL350	RGB05SCL350	RGC10SSX350	RGC10ASX350	RGC05TSX350	RGC05BSX350
4	RGC10ECL400	RGC10BCL400	RGT10BCL400	RGE10BCL400	RGB05SCL400	RGC10SSX400	RGC10ASX400	RGC05TSX400	RGC05BSX400
4.5	RGC10ECL450	RGC10BCL450	RGT10BCL450	RGE10BCL450					
5				RGE10BCL500					

MOUTHPIECES



NEW! Reserve Alto Saxophone Mouthpieces

Reserve Alto Saxophone mouthpieces capture the desired sound and provides the needed response for the most demanding modern saxophonists. Featuring exceptional intonation across all registers of the saxophone, a wide range of dynamic flexibility, and improved projection, they are ideal for the professional player or serious student. **Available Q2 2018.**

Item #	Description	Retail
MJR-D145	D145 (1.45mm, Medium Chamber)	\$250.15
MJR-D150	D150 (1.50mm, Medium Chamber)	\$250.15

TOP★SELLER

Reserve Bb Clarinet Mouthpieces

- Suited for clarinetists of all ages, abilities, and geographic locations, our six models of Reserve offer an array of resistance options in two different pitch systems.
- Milled—not molded—to the highest tolerances, Reserve offers unprecedented consistency from mouthpiece to mouthpiece, eliminating the need to try many before purchase
- Inspired by the most prized vintage mouthpieces of the 1920s and made with our own unique rubber formula, specially selected for its rich tonal properties
- Designed and made in the USA by a team of top musicians, craftsmen, and engineers
- Accessibly priced for students and professionals alike



The Reserve mouthpiece is the best mouthpiece that I have ever played! It allows me to produce a velvety rich sound that has a diamond-like shimmering core. It makes all other mouthpieces feel simple and two-dimensional.

**Richie Hawley, Professor of Clarinet, Rice University
Former Principal Clarinet, Cincinnati Symphony Orchestra**

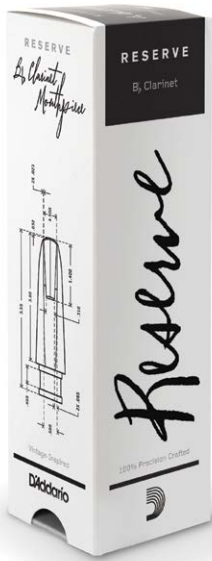

Item #	Description	Retail
MCR-X0	X0 (1.00mm, Medium-Long Facing, American Pitch)	\$207.00
MCR-X5	X5 (1.05mm, Medium-Long Facing, American Pitch)	\$207.00
MCR-X10	X10 (1.12mm, Medium-Long Facing, American Pitch)	\$207.00
MCR-X10E	X10E (1.11mm, Medium-Short Facing, European Pitch)	\$207.00
MCR-X15E	X15E (1.18mm, Long Facing, European Pitch)	\$207.00
MCR-X25E	X25E (1.25mm, Long Facing, European Pitch)	\$207.00

MOUTHPIECE SPECS & RECOMMENDED REED STRENGTHS

Mouthpieces	X0 American Pitch Tip: 1.00mm Facing: Medium-Long		X5 American Pitch Tip: 1.05mm Facing: Medium-Long		X10 American Pitch Tip: 1.12mm Facing: Medium-Long		X10E European Pitch Tip: 1.11mm Facing: Medium-Short		X15E European Pitch Tip: 1.18mm Facing: Long		X25E European Pitch Tip: 1.25mm Facing: Long	
	Rico	Reserve Classic	Rico	Reserve Classic	Rico	Reserve Classic	Rico	Reserve Classic	Rico	Reserve Classic	Rico	Reserve Classic
Beginner	3, 3.5	2.5, 3	2.5, 3	2.5	2, 2.5, 3	2, 2.5	2, 2.5	2, 2.5	2, 2.5	2, 2.5	2, 2.5	2
Intermediate	4	3, 3.5, 3.5+	3.5, 4	3, 3.5	3, 3.5	2.5, 3	3, 3.5	2.5, 3	3, 3.5	2.5, 3	2.5, 3	2.5, 3
Advanced		3.5+, 4, 4+, 4.5		3.5, 3.5+, 4, 4+		3.5, 3.5+, 4		3.5, 3.5+, 4		3, 3.5, 3.5+, 4		3, 3.5, 3.5+

MOUTHPIECE COMPARISON CHART

Brand	Requires higher strength reeds						Requires lower strength reeds					
Reserve	X0	X5		X10		X10E		X15E		X25E		
Vandoren	M13 / M13 Lyre	M15	5RV Lyre	5RV	M30 Lyre	BD5	B40 Lyre	M30	B40	B45 Lyre/B45		
Backun	CRT	LRT	TRT	ORT	Pl.10		PRT+	ORT+	PRT/ART2	ART		
Fobes	CF/CWF	Debut/CF+	2M	2L	3L		4L					
Gigliotti	P34	2	3		4							
Hawkins	B	R										
Hite		41	Pr		41J							
Lomax	A1	S2/O2	A2/S3/O4	A3	A3+	S4	A4			AM		
PlayEasy							M1	B2	B1	B3		
Pomarico		Emerald	Nigun		Ruby			Sapphire		Diamond		
Selmer	B	B*	C/C*/Focus				Concept					
Smith	1*	1+	1++		CH1							
Yamaha		4C	2M	5C								

MOUTHPIECES



TOP★SELLER

Select Jazz Saxophone Mouthpieces

- Expertly designed and made in the USA by a team of top musicians and engineers
- The Select Jazz line is milled – not molded – from solid rod rubber, using D'Addario's precise computer-controlled mouthpiece-making technology
- No hand-finishing for greater consistency
- Featuring classic sound and response, with even intonation across the entire range of the saxophone
- Medium chambers and facing lengths for exceptional versatility in all styles of jazz

Alto Saxophone

Retail	\$268.90	
Model	Facing	
D5M	MJS-D5M	(.073" or 1.86mm)
D6M	MJS-D6M	(.078" or 1.98mm)
D7M	MJS-D7M	(.083" or 2.10mm)
D8M	MJS-D8M	(.088" or 2.24mm)

ALTO SAXOPHONE MOUTHPIECE TIP OPENING COMPARISON CHART

Model	64	65	66	67	68	69	70	71	72	73	74	75	76	77	78	79	80	81	82	83	84	85	86	87	88	89	90
D'Addario Select Jazz										D5M					D6M						D7M					D8M	
Beechler		3					4					5					6						7				8
Brilhart					2/2*			3/3*			4/4*			5/5*			6/6*			7/7*		8/8*					
Dukoff		4					5					6					7					8					9
Hite	M64			M68	P			A																			
Jody Jazz HR									5M						6M					7M							8M
Lakey																	4					5				6	
Lawton		5*					6					6*					7					7*					8
Lebayle							6					6*		7										7*			
Otto Link		5					5*					6					6*					7					7*
Meyer								5					6					7					8				
Rico Graftonite							3										5										7
Rico Metalite																	5										7
Rousseau Classical		5R																									
Rousseau Jazz		X4			X5	X6			X7			X8															
Rousseau Studio Jazz		SJ4		SJ5		SJ6		SJ7		SJ8																	
Runyon			4				5				6				7					8							9
Selmer				C*				C**			D				E									F			
Ted Klum					4				5					6			7			8					9		10
Theo Wayne							5						6					7						8			
Vandoren											A5				A6			A7						A8			A9



Tenor Saxophone		
Retail	\$314.80	
Model	Facing	
D6M	MKS-D6M	(.100" or 2.54mm)
D7M	MKS-D7M	(.105" or 2.66mm)
D8M	MKS-D8M	(.110" or 2.79mm)
D9M	MKS-D9M	(.115" or 2.92mm)

visit daddario.com/selectjazz for more info



With this [Select Jazz] mouthpiece, I am immediately able to reach inside my ears for whatever sound I want, and it then comes out of my horn.

Will Vinson,
New York City-based Alto
Saxophonist and Composer

TENOR SAXOPHONE MOUTHPIECE TIP OPENING COMPARISON CHART

Model	95	96	97	98	99	100	101	102	103	104	105	106	107	108	109	110	111	112	113	114	115	116	117	118	119	120
D'Addario Select Jazz						D6M					D7M					D8M					D9M					
Beechler	7					8					9					10					11					
Berg Larsen	95					100					105					110					115					120
Brilhart				8												9										
Dukoff	6										7										8					
Jody Jazz HR	6*					7					7*					8					8*					
Lakey	5*3										6*3					7*3										8*3
Lawton	6*					7					7*					8					8*					9
Lebayle	7										7*					8					8*					9
Otto Link	6*					7					7*					8					8*					9
Meyer					9M					10M																
Rico Graftonite	5										7															
Rico Metalite	5										7										9					
Rousseau				4		5					6					7					8					
Runyon	8					9				10						12					13					14
Selmer				G							H										I					J
Ted Klum	6*					7					7*					8					8*					9
Theo Wayne	6*										7*					8					8*					9
Vandoren				T6								T7				T8					T9					T10

MOUTHPIECES



Metalite™ Mouthpiece

A favorite among jazz musicians, each Metalite mouthpiece is crafted from a durable and resonant material to offer the sound of a metal mouthpiece without the expense. Metalite mouthpieces feature a medium chamber and are available in three tip openings.

- Ideal for jazz musicians
- Available for the full range of saxophones
- Offered in two tip openings for soprano and alto saxophones
- Offered in three tip openings for tenor and baritone saxophones

	Soprano Sax	Alto Sax	Tenor Sax	Baritone Sax
Retail	\$68.75	\$68.75	\$68.75	\$68.75
Model				
M5	MIM-5	MJM-5	MKM-5	MLM-5
M7	MIM-7	MJM-7	MKM-7	MLM-7
M9			MKM-9	MLM-9

Graftonite™ Mouthpiece

The Graftonite line of mouthpieces, designed by Arnold Brillhart, incorporates revolutionary materials to achieve ease of tone production. Each Graftonite mouthpiece is made from durable polycarbonate material. They are available in three tip openings, three chamber sizes, and are priced affordably, making them ideal for students.

- Available for the full range of saxophones and Bb clarinet
- Choose from three different tip openings
- Offered in three chamber sizes for Bb clarinet and alto/tenor saxophones
- Offered in medium chamber for soprano and baritone saxophones

	Bb Clarinet	Soprano Sax	Alto Sax	Tenor Sax	Baritone Sax
Retail	\$48.75	\$43.75	\$48.75	\$50.00	\$52.50
Model					
A3	RRGMPBCLA3		RRGMPCASXA3	RRGMPCTSXA3	
A5	RRGMPBCLA5		RRGMPCASXA5	RRGMPCTSXA5	
A7	RRGMPBCLA7		RRGMPCASXA7	RRGMPCTSXA7	
B3	RRGMPBCCLB3	RRGMPCSSXB3	RRGMPCASXB3	RRGMPCTSXB3	RRGMPCBSXB3
B5	RRGMPBCCLB5	RRGMPCSSXB5	RRGMPCASXB5	RRGMPCTSXB5	RRGMPCBSXB5
B7	RRGMPBCCLB7	RRGMPCSSXB7	RRGMPCASXB7	RRGMPCTSXB7	RRGMPCBSXB7
C3	RRGMPBCCLC3		RRGMPCASXC3	RRGMPCTSXC3	
C5	RRGMPBCCLC5		RRGMPCASXC5	RRGMPCTSXC5	
C7	RRGMPBCCLC7		RRGMPCASXC7	RRGMPCTSXC7	



METALITE/GRAFTONITE MOUTHPIECE REFERENCE CHART

Model	Brand	Tip Opening	Facing Length	Chamber
	Bb Clarinet	in inches	in mm	
RRGMPCCLA3	Graftonite	.045"	18mm	Largest
RRGMPCCLA5	Graftonite	.050"	19mm	Largest
RRGMPCCLA7	Graftonite	.055"	20mm	Largest
RRGMPCCLB3	Graftonite	.045"	18mm	Medium
RRGMPCCLB5	Graftonite	.050"	19mm	Medium
RRGMPCCLB7	Graftonite	.055"	20mm	Medium
RRGMPCCLC3	Graftonite	.045"	18mm	Small
RRGMPCCLC5	Graftonite	.050"	19mm	Small
RRGMPCCLC7	Graftonite	.055"	20mm	Small
	Soprano Sax			
RRGMPCSSXB3	Graftonite	.055"	17mm	Medium
RRGMPCSSXB5	Graftonite	.060"	18mm	Medium
RRGMPCSSXB7	Graftonite	.065"	19mm	Medium
MIM-5	Metalite	.060"	18mm	Medium
MIM-7	Metalite	.065"	19mm	Medium
	Alto Sax			
RRGMPCASXA3	Graftonite	.070"	18mm	Largest
RRGMPCASXA5	Graftonite	.080"	20mm	Largest
RRGMPCASXA7	Graftonite	.090"	21.5mm	Largest
RRGMPCASXB3	Graftonite	.070"	18mm	Medium
RRGMPCASXB5	Graftonite	.080"	20mm	Medium
RRGMPCASXB7	Graftonite	.090"	21.5mm	Medium
RRGMPCASXC3	Graftonite	.070"	18mm	Small
RRGMPCASXC5	Graftonite	.080"	20mm	Small
RRGMPCASXC7	Graftonite	.090"	21.5mm	Small
MJM-5	Metalite	.080"	20mm	Medium
MJM-7	Metalite	.090"	21.5mm	Medium
	Tenor Sax			
RRGMPTSA3	Graftonite	.085"	22mm	Largest
RRGMPTSA5	Graftonite	.095"	23mm	Largest
RRGMPTSA7	Graftonite	.105"	24mm	Largest
RRGMPTSB3	Graftonite	.085"	22mm	Medium
RRGMPTSB5	Graftonite	.095"	23mm	Medium
RRGMPTSB7	Graftonite	.105"	24mm	Medium
RRGMPTSC3	Graftonite	.085"	22mm	Small
RRGMPTSC5	Graftonite	.095"	23mm	Small
RRGMPTSC7	Graftonite	.105"	24mm	Small
MKM-5	Metalite	.095"	23mm	Medium
MKM-7	Metalite	.105"	24mm	Medium
MKM-9	Metalite	.115"	25mm	Medium
	Baritone Sax			
RRGMPCBSXB3	Graftonite	.090"	23mm	Medium
RRGMPCBSXB5	Graftonite	.100"	25mm	Medium
RRGMPCBSXB7	Graftonite	.110"	26mm	Medium
MLM-5	Metalite	.100"	25mm	Medium
MLM-7	Metalite	.110"	26mm	Medium
MLM-9	Metalite	.120"	26mm	Medium

LIGATURES & CAPS

H-Ligature and Cap Sets

The H-Ligature was conceived as a “retro” version of the famous Harrison ligature, used by many of the world’s greatest saxophonists and clarinetists. H-Ligatures make use of a four-point system, which applies equal pressure to the reed, and feature a two-screw, inverted design. Each comes with our signature mouthpiece cap, innovatively made of soft, over-molded plastic.

- Gold and silver plating options
- Features a two-screw, inverted design as well as a four-point system, which applies equal pressure to the reed
- Available for the full range of clarinets and saxophones

Item #	Instrument	Description	Retail
HEC1S	Eb Clarinet	Silver	\$83.15
HCL1S	Bb Clarinet	Silver	\$71.90
HCL1G	Bb Clarinet	Gold	\$83.15
HBC1S	Bass Clarinet	Silver	\$112.50
HSS1G	Soprano Sax	Gold	\$85.00
HAS1S	Alto Sax	Silver	\$83.15
HAS1G	Alto Sax	Gold	\$103.15
HTS1G	Tenor Sax (Hard Rubber)	Gold	\$96.90
HTS2G	Tenor Sax (Otto Link Style)	Gold	\$96.90
HBS1G	Tenor/Baritone Sax (Graftonite/Metalite Mouthpiece)	Gold	\$112.50
HBS2G	Baritone Sax (Selmer™ Style Mouthpiece)	Gold	\$112.50



Rico Ligature

The Rico ligature was designed to provide excellent response and function at an affordable price. It features a four-point system that applies equal pressure to the reed. Rico ligatures are nickel-plated and feature a two-screw, inverted design. The Rico ligature is available both with and without our signature mouthpiece cap, innovatively made of soft, over-molded plastic.

- Nickel-plated
- Features a two-screw, inverted design as well as Rico’s four-point system, which applies equal pressure to the reed
- Available for the full range of clarinets and saxophones



Ligature Only		
Item #	Instrument	Retail
RCL1LN	Bb Clarinet	\$24.70
RSS1LN	Soprano Sax	\$35.65
RAS1LN	Alto Sax	\$32.50
RTS1LN	Tenor Sax (Hard Rubber)	\$35.65
RTS2LN	Tenor Sax (Otto Link Style)	\$35.65
RBS1LN	Tenor/Baritone Sax (Graftonite/Metalite Mouthpiece)	\$40.00

Ligature and Cap Sets		
Item #	Instrument	Retail
RCL1N	Bb Clarinet	\$41.25
RSS1N	Soprano Sax	\$55.00
RAS1N	Alto Sax	\$51.25
RTS1N	Tenor Sax (Hard Rubber)	\$55.00
RBS1N	Tenor/Baritone Sax (Graftonite/Metalite Mouthpiece)	\$63.75

Mouthpiece Cap

Our signature mouthpiece cap features a soft, over-molded plastic design. Each cap features rails that fit snugly against the mouthpiece. Made of flexible material, our cap is virtually indestructible and will not break, chip, or make noise if dropped.

- Offered for both inverted and non-inverted ligatures
- Fits Bonade, Ishimori, Robert Scott, Kaspar, and most other standard metal ligatures
- Will not break, chip, or make noise

For Inverted Ligatures (Screws Behind Reed)

Item #	Instrument	Retail
RCL1C	Bb Clarinet	\$21.25
RAS1C	Alto Sax	\$23.75
RTS1C	Tenor Sax (Hard Rubber)	\$33.50

For Non-Inverted Ligatures (Screws in Front of Reed)

Item #	Instrument	Retail
RCL2C	Bb Clarinet	\$21.25
RAS2C	Alto Sax	\$23.75

Bulk Ligatures & Caps

Rico Nickel Ligature Only - 50 Bulk

Item #	Instrument
RCL1LN-B	Bb Clarinet
RSS1LN-B	Soprano Sax
RAS1LN-B	Alto Sax
RTS1LN-B	Tenor Sax (Hard Rubber)
RBS1LN-B	Tenor/Baritone Sax (Graftonite/Metalite Mouthpiece)

Cap Only - 50 Bulk

Item #	Instrument	Description
RCL1C-B	Bb Clarinet	Inverted
RCL2C-B	Bb Clarinet	Non-Inverted
RAS1C-B	Alto Sax	Inverted
RAS2C-B	Alto Sax	Non-Inverted
RTS1C-B	Tenor Sax (Hard Rubber)	Inverted

Please contact your sales rep for bulk pricing.



INSTRUMENT STRAPS

All saxophone straps feature our unique quick-adjust slider, which allows the musician to adjust the strap to a precise length, quickly and easily. Our straps remain taut and sturdy at the desired length, preventing the instrument from moving and allowing the player to maintain a constant and consistent embouchure and hand position.

- Offered in two lengths: one for soprano and alto saxophones, and one for tenor and baritone saxophones
- Available in woven fabric and padded memory foam
- Feature either our signature metal hook or the classic plastic snap hook for connecting the strap to the instrument
 - ~ Metal hooks are curved and easy to insert and remove, whereas plastic snap hooks feature a mechanism that opens and closes to fasten to the instrument

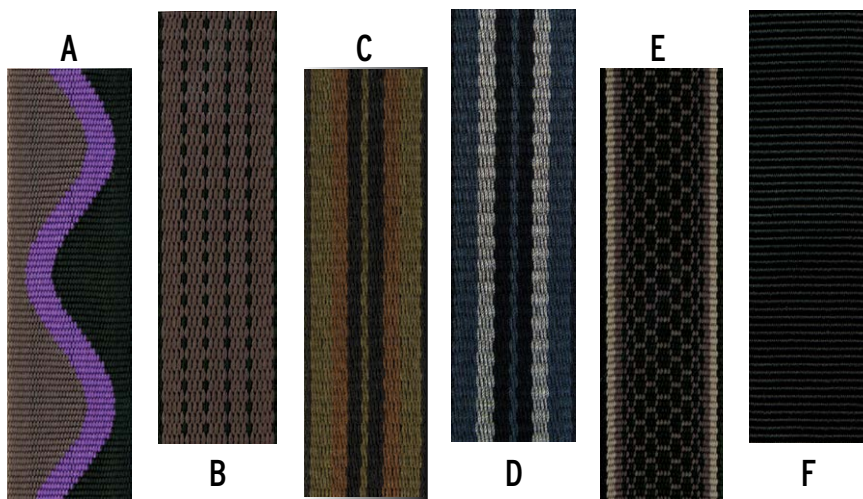

NEW STRAPS COMING IN 2018!

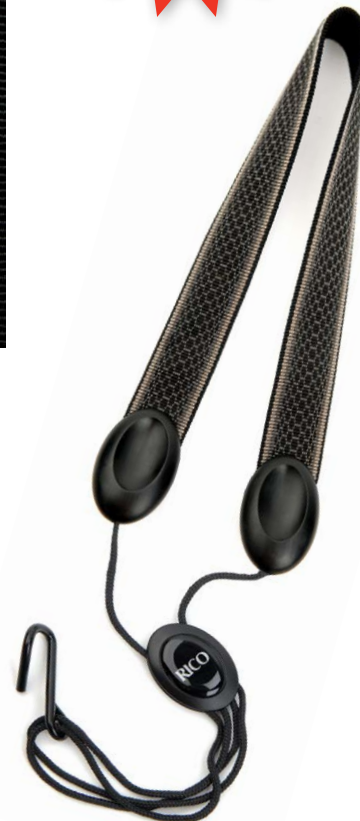

Fabric Saxophone Straps

	Item #	Instrument	Material	Design	Hook	Retail
A	SJA01	Soprano/Alto	Fabric	Jazz Wave	Metal	\$27.50
	SLA10	Tenor/Bari				
B	SJA02	Soprano/Alto	Fabric	Industrial	Metal	\$27.50
	SLA09	Tenor/Bari				
C	SJA03	Soprano/Alto	Fabric	Jazz Stripe 2	Metal	\$27.50
	SLA08	Tenor/Bari				
D	SJA04	Soprano/Alto	Fabric	Jazz Stripe 1	Metal	\$27.50
	SLA07	Tenor/Bari				
E	SJA05	Soprano/Alto	Fabric	Gray Scales	Metal	\$27.50
	SLA06	Tenor/Bari				
F	SJA11	Soprano/Alto	Fabric	Solid Black	Metal	\$27.50
	SLA11	Tenor/Bari				
F	SJA13	Soprano/Alto	Fabric	Solid Black	Snap	\$27.50
	SLA13	Tenor/Bari				

Padded Saxophone Straps

- Made from plush memory foam, providing extra comfort on your neck
- Each strap is covered in a breathable, athletic material that is comfortable and stays dry

Item #	Instrument	Material	Hook	Retail
SJA12	Soprano/Alto Sax	Padded	Metal	\$53.75
SLA12	Tenor/Bari Sax	Padded	Metal	\$53.75
SJA18	Soprano/Alto Sax	Padded	Snap	\$53.75
SLA18	Tenor/Bari Sax	Padded	Snap	\$53.75



Snap Hook



Metal Hook



The Padded Sax strap is a great strap on stage. It's very comfortable and durable.

**Jason Marshall,
Mingus Big Band**

Clarinet Strap

- Made of woven fabric
- Designed to fit most Bb and A clarinets
- Features a sturdy leather tab to connect strap to the thumb rest

Item #	Description	Hook	Retail
CCA01	Clarinet Strap with Thumb Tab	Metal	\$41.25



REED CASES & ACCESSORIES

TOP★SELLER

D'Addario Multi-Instrument Reed Storage Case

D'Addario's signature reed case holds eight of any size clarinet or saxophone reeds, from Eb clarinet through baritone saxophone. Reeds are held snugly to a grooved surface which prevents warping. The airtight gasket ensures a proper seal which keeps reeds safe and stable when traveling. Each of our reed storage cases comes with one humidity control pack in 72% Relative Humidity and features Reed Vitalizer two-way humidity control technology.

Item #	Instrument	Description	Retail
RVCASE04	Multi-Instrument	Reed Case with RV0173	\$60.00



D'Addario Double Reed Storage Case

D'Addario's signature reed case holds five oboe, oboe d'amore, English horn, or bassoon reeds in any combination. The airtight gasket ensures a proper seal which keeps reeds safe and stable when traveling. Featuring Reed Vitalizer two-way humidity control technology, each of our reed storage cases comes with one humidity control pack in 72% Relative Humidity.

Item #	Instrument	Description	Retail
RVCASE05	Oboe/Bassoon	Reed Case with RV0173	\$60.00



TOP★SELLER

D'Addario Reed Vitalizer™

Reed Vitalizer offers maintenance-free reed storage. The patented technology uses two-way humidity control to prevent warping and keep your reeds stable in any weather conditions. Reed Vitalizer Humidity Control packs will last 45-60 days. When the pack becomes hard, simply discard and replace with a new pack.

Item #	Retail
RV0173	\$5.30



Smart Pak™

Item #	Description	Retail
RSMPEAKBCL	Bb Clarinet	\$80.00
RSMPEAKASX	Alto Sax	\$87.50

Contains: mouthpiece, ligature, cap, mouthpiece saver, cork grease, and Reed Guard II with 2 reeds.



Mouthpiece Patches

Designed to protect your mouthpiece, the Reserve mouthpiece patch is ideal for clarinetists and saxophonists of all ages and abilities. Ideal for educational purposes, the Reserve mouthpiece patch prevents the teeth from sliding on the mouthpiece. It can be a useful tool in promoting the correct development of various aspects of embouchure and tone production, especially how much mouthpiece to take and the prevention of biting. Our unique material adheres securely to the mouthpiece, yet enables easy removal or transfer when needed.

Item #	Description	Retail
RMP01B	Sheet of 5 - Black (.80mm thickness)	\$14.40
RMP01C	Sheet of 5 - Clear (.35mm thickness)	\$14.40



Mouthpiece Savers

Item #	Instrument	Descript.	Retail
RMPSVRBCL	Bb Clar/Alto	Single (wrapped)	\$5.65
RMPSVRBCL01	Bb Clar/Alto	POP Box of 12	\$45.65
RMPSVRTSX	Tenor/Bari Sax	Single (wrapped)	\$6.85
RMPSVRTSX01	Tenor/Bari Sax	POP Box of 12	\$52.50

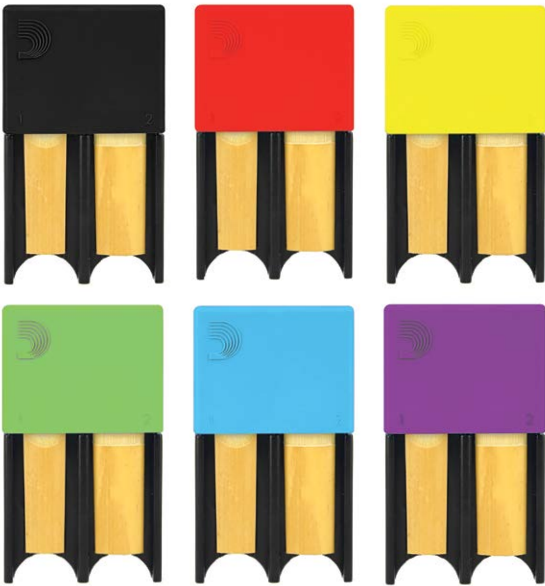

MUST★HAVE

D'Addario Reed Guards *Innovation in Protection*

Our D'Addario reed guards offer a convenient, affordable storage solution for students, educators, and artists. The soft elastomer cover is designed to securely but gently hold reeds.

- Available in black, red, yellow, green, blue, and purple
- Each reed guard holds four reeds
- Grooved surfaces prevent reed warping

For B♭ Clarinet, E♭ Clarinet, Soprano Saxophone, & Alto Saxophone

Item #	Size	Color	Retail
DRGRD4ACBK	Small	Black	\$12.70
DRGRD4ACRD	Small	Red	\$12.70
DRGRD4ACYL	Small	Yellow	\$12.70
DRGRD4ACGR	Small	Green	\$12.70
DRGRD4ACBL	Small	Blue	\$12.70
DRGRD4ACPU	Small	Purple	\$12.70

For Tenor Saxophone, Baritone Saxophone, & Bass Clarinet

Item #	Size	Color	Retail
DRGRD4TBBK	Large	Black	\$12.70
DRGRD4TBRD	Large	Red	\$12.70
DRGRD4TBYL	Large	Yellow	\$12.70
DRGRD4TBGR	Large	Green	\$12.70
DRGRD4TBBL	Large	Blue	\$12.70
DRGRD4TBPU	Large	Purple	\$12.70



Rico Reed Guards

The Rico Reed Guard IV is the simplest, most effective way to keep your reeds safe and secure.

- Convenient, affordable storage solution for students, educators, and artists
- Holds four reeds and is sold individually

Item #	Instrument	Description	Retail
RGRD4ASCL	Clarinet/Alto	Reed Guard IV - 1 pc.	\$11.25
RGRD4TSBS	Tenor/Bari Sax	Reed Guard IV - 1 pc.	\$11.25

Bulk Rico Reed Guards

Item #	Instrument	Description	Color
RG2BCLBLACK	Clarinet/Alto	Reed Guard II - Bulk Pack	Black
RG2TSXBLACK	Tenor/Bari Sax	Reed Guard II - Bulk Pack	Black
RGRD4BCL01	Clarinet/Alto	Reed Guard IV - Bulk Pack	Black
RGRD4TSX01	Tenor/Bari Sax	Reed Guard IV - Bulk Pack	Black

Minimum order quantity 250 pieces. Please contact your sales rep for pricing.



TOP★SELLER

D'Addario All-Natural Cork Grease

This premium cork grease features ingredients such as organic coconut oil, organic sunflower oil, and organic hemp seed oil. It provides ample, lasting, non-greasy lubrication to keep corks at their best and prevent them from breaking down.

Item #	Description	Retail
DCRKGR01	Single Tube	\$7.80
DCRKGR12	12-Tube Display Box	\$93.75

Padgards

Item #	Description	Retail
RPADGPIC01	Piccolo Padgard	\$16.55
RPADGFLT01	Flute Padgard	\$21.25
RPADGBCL01	Clarinet Padgard	\$23.75
RPADGSSX01	Soprano Padgard	\$32.50
RPADGASX01	Alto Padgard	\$36.25
RPADGTSX01	Tenor Padgard	\$38.75

Neck Savers

Item #	Description	Retail
RNSASX01	Neck Saver / Alto Sax	\$16.25
RNSTSX01	Neck Saver / Tenor Sax	\$16.25



Rico Cork Grease

Lubricates and prevents damage to corks and instrument.

Item #	Description	Retail
RCRKGR01	Single Tube	\$4.15
RCRKGR12	12-Tube Display Box	\$36.50

Practice Grip Instrumental Hand Exerciser

A pocket-sized hand and finger exerciser ideal for woodwind and brass instrumentalists who use keys or valves.

This conditioning tool is designed with light overall tension to foster proper, healthy finger motion, digital independence, and increased finger speed and dexterity.

Item #	Retail
WW-PG-01	\$28.75



INSTRUMENT CARE

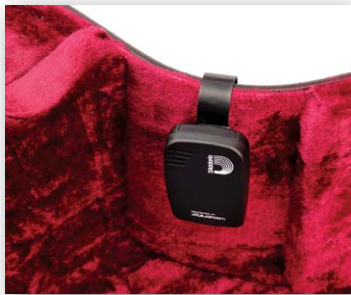

Humiditrak™

Musical instruments can be easily damaged by large and rapid changes in humidity and temperature. Now you can protect your investments by simply placing D'Addario's Humiditrak with Blustream Technology™ inside your instrument or case. Humiditrak uses a patent-pending Bluetooth sensor to provide a constant stream of temperature, humidity, and impact data to the free smartphone app to alert you of hazardous conditions that can lead to diminished playability, costly repairs, and lost value to your instrument. When Humiditrak detects dangerous conditions, push notifications are sent to your device, allowing you to take corrective action before damage occurs. Cataloging and monitoring a collection of instruments is so easy and convenient, you'll want one for every instrument you own!

- iOS/Android instrument monitoring
- Hourly, daily & monthly data tracking
- Easily installs within instrument or case
- Automatic push notifications of hazardous conditions



**FREE
SMART-
PHONE
APP**

Item #	Retail
PW-HTK-01	\$87.45



Humidity & Temperature Sensor

The D'Addario Humidity & Temperature Sensor (HTS) will help monitor your instrument's climatic conditions to avoid damage and costly repairs.

- The precision-designed hygrometer digitally indicates accurate Relative Humidity level
- Temperature is displayed in either Fahrenheit or Celsius
- Includes memory of highest and lowest readings with date and time stamp

Item #	Description	Retail
PW-HTS	Humidity & Temperature Sensor	\$45.55



TOP★SELLER

Humidipak: Two-Way Humidification System

D'Addario brings you Boveda's® patented technology as part of our instrument care line. Boveda is the first two-way humidity control that maintains a constant 45-50% Relative Humidity level inside your instrument case. The patented Two-Way Humidification System completely eliminates all the guesswork and anxiety of maintaining your instrument's proper humidity level. No more guessing if or when to refill the humidifier and worrying about drips or mess. No more manual adjustments based on seasonal changes, geographic locations, temperature, or other factors. Unlike all refillable humidifiers, this humidification system provides true two-way purified humidity control since it adds or depletes moisture only as needed to maintain 45-50% RH – the ideal climate for wooden instruments.

Item #	Description	Retail
PW-HPK-01	Humidipak Maintain Kit	\$45.35
PW-HPRP-03	Standard Refill Packet - 3-pack	\$29.15
PW-HPRP-12	Standard Refill Packet - 12-pack	\$101.85

Boveda's technology is protected by one or more of the following patents: 5936178, 2298597, 1064644, 6921026, 6244432, 8748723.



Small Instrument Humidifier

The Small Instrument Humidifier releases moisture evenly and slowly inside your instrument's case to maintain the proper humidity level, preventing cracks, warping, and shrinkage. Using the humidifier is as easy as moistening the sponge when it becomes dry. Get one for all of your valuable instruments. It's the smart, easy, and affordable way to protect your investments.

- Small size fits in any case
- Ideal for smaller acoustic, orchestral, and woodwind instruments
- Releases moisture slowly and evenly
- Safe for all instruments

Item #	Retail
PW-SIH-01	\$11.65

TOP ★ SELLER

Eclipse Tuner

The Eclipse chromatic clip-on tuner offers fast, accurate tuning on and off the stage. The tuner features a full-color vertical display, auto power-off, and pitch calibration in a discreet, compact design. The dual-swivel action allows the perfect viewing angle. Available in multiple colors.

- Quick, Accurate Tuning
- Full-color display
- Dual 360-degree swivel points for limitless viewing angles

Item #	Description	Retail
PW-CT-17BK	Black	\$21.50
PW-CT-17YL	Yellow	\$21.50
PW-CT-17GN	Green	\$21.50
PW-CT-17RD	Red	\$21.50
PW-CT-17PR	Purple	\$21.50
PW-CT-17BU	Blue	\$21.50
PW-CT-17MP	10-pack assorted colors: 5 black, 1 red, 1 blue, 1 yellow, 1 green, 1 purple	\$214.90



Pacato Hearing Protection

D'Addario Pacato Hearing Protection is a reusable, universal-sized audio filter designed specifically for musicians and music enthusiasts. While other hearing protection can sound muffled and unnatural, Pacato filters provide full frequency and enjoyable audio at safe listening levels. The exclusive design offers an open air passage to the ear, minimizing occlusion effects (low frequency emphasis) while keeping the ear ventilated for unmatched comfort.

- Provides a noise reduction rating of 19dB
- Includes large and small earplugs, lanyard, and carrying case

Item #	Retail
PWPEP1	\$43.15



Untreated Polishing Cloth

Made from high-quality, double-napped cotton flannel, D'Addario Polishing Cloths pick up dust and dirt more effectively than ordinary polishing cloths and last longer.

Item #	Retail
PWPC2	\$8.75



Comfort Fit Ear Plugs

D'Addario Comfort Fit Ear Plugs are made from slow recovery PVC foam, and provide a noise reduction rating of 29 db.

Item #	Description	Retail
PWEP1	1 pair	\$2.65
PWEP3	3 pairs	\$7.05
PWEP100	100 pairs in fish bowl	\$209.35

DISPLAYS



Rico / Royal 10-Reed Box Countertop Display

- Holds 18 total 10-reed boxes
- Measures 12" x 12" x 7"

Item #	Description
RDA-10C	Display



Reserve / Select Jazz Mouthpiece Countertop Display

- Holds 9 total mouthpieces
- Measures 9" x 11" x 11.5"
- Includes two interchangeable front panel graphics: Reserve and Select Jazz

Item #	Description
WWDA-MPC1	Display



D'Addario Brochure Rack

This wire frame holder attaches neatly onto any slatwall, EVUMS or JRUMS fixture and will fit any of our branded gear or survival guide brochures. Item # DD-WLH

Reed Displays

An easy and effective way to showcase all of our reed offerings, our spring-loaded racks fit all 5-, 10-, and 25-quantity reed boxes. They are easily mounted to slatwall and pegboard displays, or can sit flat on a counter or in a display case.

Item #	Description
A RDA-10S	10-Reed Box Display (Empty)
B RDA-05S/L	5-Reed Box Display (Empty)
C RDA-50/25	Rico 25-Reed (Novapak) Display Bb Clarinet/Alto Saxophone (Empty)
D RDA-25L	Rico 25-Reed (Novapak) Display Tenor/Baritone Saxophone (Empty) (not shown)

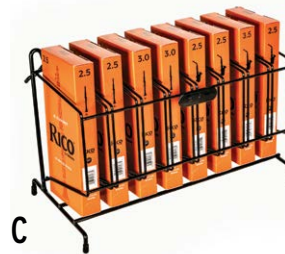

A note from Sales

D'Addario offers a variety of display options for your store. Contact your sales rep to learn more. 1-800-268-6855 orders@daddario.com

OTHER BRANDS

DANELECTRO, SUZUKI, BEAVERCREEK,
TUNE-BOT, TYPHOON, SHADOW, ZEV,
ENERGIZER, TYCOON, SOLUTIONS, D&A, STRUKTURE,
DAVA, MUSIC STAMP, KAZOOBIE KAZOOS +



DANELECTRO GUITARS



Baby Sitar

- Round body shape
- "Thermometer" headstock shape
- 6 strings tuned like standard guitar
- Scale length: 25
- Number of frets: 21
- Gotoh sitar bridge
- 1 lipstick® pickup
- 1 master volume • 1 master tone

Item#	Description	Retail
D-BSITAR	Tobacco burst	\$1337.00



'56 Series

- Single cut body shape
- "Dolphin" headstock
- Baritone & Bass: 29.75" short-scale neck w/24 frets
- Guitar: 25" scale length w/19 frets
- Fully adjustable bridge
- 2 high output, high impedance Lipstick® pickups
- 1 master volume • 1 master tone
- 3 way pickup selector

Item#	Description	Retail
D56BARI-BLACK	Baritone - Black	\$904.50
D56-BLACK	Guitar - Black	\$786.50



Longhorn Series

- 1958 longhorn bass body shape
- 29.75 short-scale neck
- Number of frets: 24
- Traditional bridge with single rosewood saddle
- 2 high output, high impedance lipstick® pickups
- 2 stacked volume/tone control sets

Item#	Description	Retail
D58BASS-CB	Sh. scale - Cop. burst	\$865.50
D58-CB	Guitar - Cop. burst	\$865.50



'56 Vintage Bari

- Single cut body shape
- "Dolphin" headstock
- 29.75 scale neck
- Number of frets: 24
- Fully adjustable bridge
- 2 high output, high impedance Lipstick®pickups
- 1 master volume
- 1 master tone
- 3 way pickup selector
- "S" sound hole

Item#	Description	Retail
D56VBARI-AQUA	Aqua	\$904.50
D56VBARI-REDMETALLIC	Red Metallic	\$904.50
D56VBARI-WHITE	White	\$904.50



NEW '59X Series

- Double cutaway
- Shorthorn shape
- Number of frets: 21
- High output single coil in neck
- Lipstick® Humbucker pair in bridge
- 2 stacked tone & volume controls
- 3-way pickup selector

Item#	Description	Retail
D59X-AQUA	Aqua	\$924.50
D59X-BLACK	Black	\$924.50



NEW '59XT Series

- Double cutaway
- Shorthorn shape
- Number of frets: 21
- High output single coil in neck
- Lipstick® Humbucker pair in bridge
- 2 stacked tone & volume controls
- 3-way pickup selector
- Wilkinson tremolo

Item#	Description	Retail
D59XT-BLACK	Black	\$1042.00
D59XT-CREAM	Cream	\$1042.00





'59 Series

- Shorthorn shape
- Scale length: 25
- Number of frets: 21
- Fully adjustable wraparound bridge
- 2 NOS (15 year old) lipstick® pickups
- 2 stacked tone & volume controls
- 3 way pickup selector

Item#	Description	Retail
D59M-BLACK	Black Guitar	\$826.00
D59ML-BLACK	Left Handed Guitar	\$826.00



'59 12-String

- Shorthorn shape with f-hole
- Scale length: 25
- Number of frets: 21
- Fully adjustable 12 string bridge
- 2 lipstick® pickups
- 1 master volume • 1 master tone
- 3 way pickup selector

Item#	Description	Retail
D5912-BLACK	Black	\$865.50
D5912-CS	Cherry Sunburst	\$865.50



'59 Vintage 12 String

- Shorthorn shape
- Scale length: 25
- Number of frets: 21
- Fully adjustable 12 string bridge
- 2 Lipstick® pickups
- 1 master volume
- 1 master tone
- 3 way pickup selector
- "S" sound hole

Item#	Description	Retail
D5912V-AQUA	Aqua	\$904.50



'84 Series

- Solid body electric guitar
- Double cutaway offset horn shape
- Scale length: 25.5
- Number of frets: 21 (graphite nut)
- Wilkinson vibrato bridge
- 3 single coil Lipstick pickups
- 1 master volume
- 1 master tone
- 5 way pickup switch
- Alderwood body, Maple neck, Rosewood board
- Nut is 41mm, radius is 14

Item#	Description	Retail
D84-SUNBURST	Sunburst	\$1361.50
D84-WHITE	White	\$1361.50



DANELECTRO PEDALS & AMPS

NEW! Billionaire Pedals | stellar tone - True Bypass Switching - Diecast Metal Case - Glossy Classic Cab Finish



Item#	Description	Retail
A D-BB-1	Billion Dollar Boost - Stellar boost of all frequencies plus clean pre amp with gobs of gain	\$39.20
B D-BK-1	Big Spender Spinning Speaker - Best ever spinning speaker tones. Rich, lush & sparkling	\$39.20
C D-BP-1	Pride of Texas - Aces the bluesy tone of one of the greatest players ever to walk the earth	\$44.10
D D-BT-1	Filthy Rich Tremolo - The richest tremolo tones ever	\$39.20
E D-	Cash Cow -	\$44.10
F D-BAT-1	Batter Billionaire - Juicy tone from vintage 1960's style batteries!	\$44.10



Fab Effects Pedals

Item#	Description	Retail
A D-1	Fab Distortion - Highly responsive with delicious tone	\$39.20
B D-2	Fab Overdrive - Authentic tube amp breakup	\$39.20
C D-3	Fab Metal - Hostile, belligerent and explosive	\$44.10
D D-4	Fab Echo - Rich, vintage tone. Thick chorus	\$39.20
E D-5	Fab Chorus - Fat echo at a skinny price	\$44.10
F D-7	Fab Fuzz - Fistfull of Fuzzy Fun. Classic to Modern	\$44.10
G D-8	Fab Delay - Thick, rich, 600 MS delay	\$62.30



Mini Pedals

Item#	Description	Retail
A DJ-5	Tuna Melt - Hard/Soft switch to perfectly simulate tremolos	\$71.20
B DJ-13	French Toast - Octave Distortion, re-issue of Foxx Tone Machine	\$89.00
C DJ-14	Fish & Chips - 7 Band EQ. Level control for boost or cut	\$89.00



Spring King

Spring Reverb

Delivers 'just the right tone and warmth.' A 'kick pad' to give an effect that sounds like a kicked amp.

Item#	Description	Retail
DSR-1	Spring reverb	\$222.60



HoneyTone Mini Amp

Louder than most mini amps. Real leather handle, and belt clip. Volume, tone, and overdrive controls. 9V battery included.

Item#	Colour	Retail
DN-10NA	Nifty Aqua	\$57.90
DN-10BBU	Burgundy	\$57.90
DN-10BLK	Black	\$57.90



Hodad Mini Amp

Powerful mini amp with two speakers, cool echo effect, vintage tremolo with adjustable speed.

Item#	Description	Colour	Retail
DH-1	Effects	Brown	\$97.90
DH-2	No Effects	Aqua	\$66.80



9 Volt Battery

You'll be amazed at the tonality you get with this old style zinc battery. Sold in boxes of 10.

Item#	Retail
DB-9V	\$2.00 each

DIATONIC HARMONICAS

Airwave | 10 Hole Starter

Sleek modern design that is easy to hold and easy to play. There are no metal screws on the outside of the instrument like traditional harmonicas. The holes you blow into to make the notes are spaced widely apart so that anyone can play it the very first time they try! Made from high quality unbreakable resin and pro quality reeds, you'll be jammin' in no time. Includes a full colour instruction booklet with access to on line demos and lessons.



Item#	Description	Retail
SU-AW1-RED	10 Hole - Red	\$25.05
SU-AW1-ORANGE	10 Hole - Orange	\$25.05
SU-AW1-BLUE	10 Hole - Blue	\$25.05

MIX, MATCH & \$AVE

Easy Rider | 10 Hole Hobbyist



Body	ABS
Cover	Stainless Steel/Aluminum
Reeds	Brass
Case	Paper

Item#	Keys	Retail
SU-EZR20	C, G	\$13.90

MIX, MATCH & \$AVE

Harp Master | 10 Hole Hobbyist



Body	ABS
Cover	Stainless Steel
Reeds	Phosphor Bronze
Case	Plastic

Item#	Keys	Retail
SU-MR200	C, G, A, D, E, F, Bb, B, F#, Eb, Ab, Db, Hi G, Low F	\$41.75

MIX, MATCH & \$AVE

Folk Master | 10 Hole Hobbyist



Body	ABS
Cover	Stainless Steel
Reeds	Brass
Case	Plastic

Item#	Keys	Retail
SU-FM1072	C, G, A, D, E, F, Bb, B, F#, Eb, Ab, Db	\$19.45

MIX, MATCH & \$AVE

Blues Master | 10 Hole Hobbyist



Body	ABS
Cover	Stainless Steel
Reeds	Phosphor Bronze
Case	Plastic

Item#	Keys	Retail
SU-MR250	C, G, A, D, E, F, Bb, B, F#, Eb, Ab, Db	\$46.50

MIX, MATCH & \$AVE

Folk Master Box Set (12)

Item#	Keys Included	Retail
SU-FM1072S	12 keys	\$227.35

Extra 10% savings plus free durable storage case



Blues Master Box Set (6)

Item#	Keys Included	Retail
SU-MR250S	C, G, A, D, F, Bb	\$278.20

Extra 10% savings plus free durable storage case



MIX & MATCH ANY 12 SUZUKI HARMONICAS & \$AVE! WHERE APPLICABLE

SUZUKI HARMONICAS

Manji | 10 Hole Professional



Body Composite
Cover Stainless Steel
Reeds Phosphor Bronze
Case Plastic

Item#	Description	Keys	Retail
SU-M-20		C, G, A, D, E, F, Bb, B, F#, Eb, Ab, Db & Hi G	\$69.95
SU-M-20M7	Major 7th	C, G, A, D, E, F, Bb	\$79.10
SU-M-20C	Country Tuning	C, G, A, D, E, F, Bb	\$79.10
SU-M-20HM	Harmonic Minor Tuning	C, G, A, D, E, F, Bb	\$79.10
SU-M-20L	Low Tuning	Low C, Low D, Low E, Low Eb, Low F	\$92.60
SU-M-20NM	Natural Minor Tuning	C, G, A, D, E, F, Bb	\$79.10

MIX, MATCH & SAVE

Pro Master | 10 Hole Professional



Body Aluminum
Cover Brass, Chrome Plated
 Gold model - 18k gold cover
Reeds Phosphor Bronze
Case Plastic

Item#	Description	Keys	Retail
SU-MR350		C, G, A, D, E, F, Bb, B, F#, Eb, Ab, Db, Hi G, Low F	\$68.75
SU-MR350V	Valved	C, G, A, D, E, F, Bb, B, F#, Eb, Ab, Db, Hi G, Low F	\$87.05
SU-MR350VG	Valved Gold	C, G, A, D, E, F, Bb, B, F#, Eb, Ab, Db, Hi G, Low F	\$180.05

MIX, MATCH & SAVE

Pro Master Box Set (6)

Item#	Keys Included	Retail
SU-MR350S	C, G, A, D, F, Bb	\$389.90

Extra 10% savings plus free durable storage case



Manji Key Set (2 or 3)

Item#	Keys Included	Retail
SU-M-20MP	C, G, A	\$203.90
SU-M-20LP	Low C & Low D	\$180.85

Extra 10% savings plus free EVA zipper case



Olive | 10 Hole Professional



Body Wood-Resin
Cover Stainless Steel
Reeds Phosphor Bronze
Case Cloth

Item#	Keys	Retail
SU-C-20	C, G, A, D, E, F, Bb, B, F#, Eb, Ab, Db, Hi G, Low F	\$77.90

MIX, MATCH & SAVE



Manji Set (7)

Item#	Keys Included	Retail
SU-M-20S	C, G, A, D, E, F, Bb	\$483.30

Extra 10% savings plus free case and polish cloth

REPLACEMENT REEDS

- Reeds are available in multiple keys
- Call for pricing

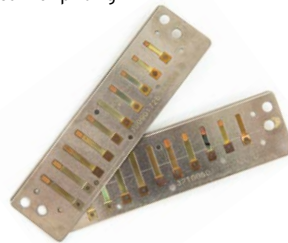

Item#	For Model:
SU-RP1072	FM-1072
SU-RP200	MR-200
SU-RP250	MR-250
SU-RP300	MR-300
SU-RP350	MR-350, PH-20
SU-RP350V	MR-350V, PH-20
SU-RP-M20	SU-M-20

more models available...

Sub 30 | 10 Hole Professional



Body ABS
Cover Brass, Chrome Plated
Reeds Phosphor Bronze
Case Plastic

Item#	Keys	Retail
SU-SUB30	C, D, A	\$186.00
MIX, MATCH & SAVE		

Pure Harp | 10 Hole Specialty



Body Rosewood
Cover Rosewood
Reeds Phosphor Bronze
Case Plastic

Item#	Keys	Retail
SU-MR550	C, G, A, D, E, F, Bb, B, F#, Eb, Ab, Db, Hi G, Low F	\$195.55

Hammond | 10 Hole Professional



Body Aluminum
Cover Brass, Black Chrome Plated
Reeds Phosphor Bronze
Case Plastic

Item#	Keys	Retail
SUH-HA20	C, G, A, D, E, F, Bb, B, F#, Eb, Ab, Db, Hi G, Low F	\$83.85

Pipe Humming | 10 Hole Specialty



Body Aluminum
Cover Brass, Chrome Plated
Reeds Phosphor Bronze
Case Cloth

Item#	Keys	Retail
SU-PH20	C, G, A, D, E, F, Bb	\$100.15

Fabulous | 10 Hole Performance



Body Brass
Cover Brass, Silver Plated
Reeds Phosphor Bronze
Case Plastic

Item#	Description	Keys	Retail
SU-F-20E	Equal Temperament	C, G, A, D, E, F, Bb & Low F	\$362.85
SU-F-20J	Just Temperament	C, G, A, D, E, F, Bb & Low F	\$362.85

Over Drive | 10 Hole Specialty



Body Aluminum
Cover Brass, Black Chrome Plated
Reeds Phosphor Bronze
Case Plastic

Item#	Keys	Retail
SU-MR300	C, G, A, D, E, F, Bb	\$68.75
MIX, MATCH & SAVE		

MIX & MATCH ANY 12 SUZUKI HARMONICAS & \$AVE! WHERE APPLICABLE

SUZUKI HARMONICAS

CHROMATIC HARMONICAS

Chromatix | Professional



Body ABS
Cover Brass, Chrome Plated
Reeds Phosphor Bronze
Case Leather

Item#	Description	Keys	Retail
SU-SCX48	12 Hole	C, G, A, D, F, Bb	\$319.15
SU-SCX56	14 Hole	C	\$370.40
SU-SCX64	16 Hole	C	\$432.40

Tremolo Chromatic Harmonica | Performance
 Professional 16 Hole Chromatic



Body Resin
Cover Brass, Chrome Plated
Reeds Phosphor bronze
Case Leather

Item# SU-SCT-128
Retail \$1698.65

Grégoire Maret | Performance



Body ABS Resin w/Brass weight
Cover Brass, Special Plating
Reeds Phosphor bronze
Case Plastic

Item# SU-G-48
Retail \$870.00

Item# SU-G-48W
Retail \$957.40

Sirius | Performance



Body ABS Resin w/ Brass weight
Cover Brass w/ Matt Black Chrome Plating
Reeds Phosphor Bronze
Case Plastic

Item#	Description	Alignment	Retail
SU-S-48S	12 Hole	Straight Alignment	\$826.25
SU-S-56S	14 Hole	Straight Alignment	\$891.85
SU-S-64C	16 Hole	Cross Alignment	\$957.40

Chord56 | Performance



Body ABS
Cover Brass, Bronze colour coating
Reeds Phosphor Bronze
Case Plastic

Item# SU-SSCH-56
Retail \$948.70

Fabulous | Performance



Body Brass
Cover Brass, Silver Plated
Reeds Phosphor Bronze
Case Leather

Item#	Description	Alignment	Retail
SU-F-48SC	12 Hole, 48 Notes	Straight Alignment	\$4240.65
SU-F-48CC	12 Hole, 48 Notes	Cross Alignment	\$4240.65
SU-F-64CC	16 Hole, 64 Notes	Cross Alignment	\$4634.10

TREMOLO HARMONICAS

Winner | Hobbyist



Body	ABS	Item#	Description	Keys	Retail
Cover	Stainless Steel	SU-W16C	16 Double Holes	C	\$11.15
Reeds	Brass	SU-W20C	20 Double Holes	C	\$13.90
Case	Paper	SU-W24C	24 Double Holes	C	\$16.70

Two Timer | Hobbyist
24 Double Holes



Body	ABS	Item#	Keys	Retail
Cover	Stainless Steel	SU-SU24-2T	C, C#, A	\$49.70
Reeds	Phosphor Bronze			
Case	Plastic			

Humming Mate | Hobbyist
13 Double Holes



Body	ABS	Item#	Keys	Retail
Cover	Stainless Steel	SU-SU13M	C, Am	\$64.40
Reeds	Phosphor Bronze			

Humming Professional | Professional
21 Double Holes



Body	ABS
Cover	Brass, Chrome Plated
Reeds	Phosphor Bronze
Case	Plastic

Item#	Keys	Retail
SU-SU21H	C, C#, D, D#, E, F, F#, G, G#, A, A#, B, Cm, Dm, Em, Fm, Gm, Am, Bm	\$95.00

Special | Professional
21 Double Holes



Body	ABS	Item#	Keys	Retail
Cover	Stainless Steel	SU-SU21SP	A, C	\$67.15
Reeds	Phosphor Bronze			
Case	Plastic			

Special 24 | Professional
Double Holes



Body	ABS	Item#	Keys	Retail
Cover	Stainless Steel	SU-SU24	C, C#	\$142.30
Reeds	Phosphor Bronze			
Case	Plastic			

Tremolo | Professional
23 Double Hole



Body	ABS	Item#	Keys	Retail
Cover	Stainless Steel	SU-SUA23	C, A, G	\$56.85
Reeds	Phosphor Bronze			
Case	Plastic			

Humming High Class | Professional
21 Double Holes



Body	ABS
Cover	Brass, Chrome Plated
Reeds	Phosphor Bronze
Case	Plastic

Item#	Keys	Retail
SU-SU21W	C, G, A, D, E, F, Bb, B, F#, Eb, Ab, Db, Hi G, Low F	\$153.00



Humming High Class Set (4)

Item#	Keys Included	Retail
SU-SU21W-4S	C, C#, A, Am	\$612.05

Extra 10% savings plus free case and polish cloth

SUZUKI HARMONICAS

ENSEMBLE HARMONICAS

Soprano Single & Alto Single 37 Holes



		Item#	Description	Keys	Retail
Body	Wood				
Cover	Brass, Black Coated	SU-SS37	Soprano	C	\$685.60
Reeds	Phosphor Bronze	SU-AS37	Alto	C	\$685.60
Case	Wood/Leather				

Baritone 21 Double Holes



		Item#	Keys	Retail
Body	ABS			
Cover	Brass, Black Coated	SU-SBH21	C, C#	\$229.70
Reeds	Phosphor Bronze			
Case	Plastic			

Chord

5 Chord patterns, 48 chords, 192 holes, 12 keys



		Item#	Retail
Body	ABS		
Cover	Stainless Steel	SU-SCH48	\$2057.55
Reeds	Phosphor Bronze		
Case	Semihard Case & Nylon Shoulder Case		

Bass Chord

5 Chord patterns, 12 keys



		Item#	Retail
Body	ABS		
Cover	Stainless Steel	SU-BCH-48	\$2011.05
Reeds	Phosphor Bronze		
Case	Semihard Case & Nylon Shoulder Case		

Double Bass

Range E~E2

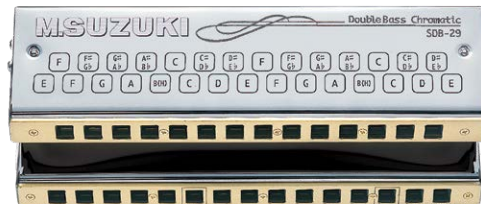

		Item#	Description	Retail
Body	ABS			
Cover	Stainless Steel	SU-SDB29	29 Hole	\$1442.07
Reeds	Phosphor Bronze	SU-SDB39	39 Hole	\$1543.25
Case	Wood Case & Nylon Shoulder Case			

MICROPHONES

Harmonica Microphones

Orchestral Chord Mic and Orchestral Bass Mic Angle adjustable. Up to 70 hours of playing.

Item#	Description	Retail
SU-HMC2	Mic for SCH-48	\$1031.35
SU-HMC4	Mic for SCH-24	\$898.60
SU-HMB1	Mic for SDB-39	\$738.05
SU-HMB3	Mic for SDB-29	\$652.60



Condensor Microphone Set

- The sound is crispy, detailed and makes your harmonica sing
- Low cut for bass frequencies, which reduces handling noises

Item#	Retail
SU-HMH100	\$257.95

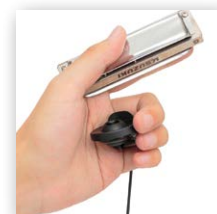

HARMONICA SOFT CASES



Item #	Description	Retail
SU-HSC-D6D	Diatonic Soft Case for 6 Harps	\$21.85
SU-HSC-T4B	Tremolo Soft Case for 4 Harps	\$21.85
SU-10HC-8	Diatonic Soft Case for 8 Harps	\$68.35
SU-SHC-8	Tremolo Soft Case for 8 Harps	\$77.90

HARMONICA HARD CASES



Item #	Description	Retail
SU-10HC-6	Diatonic Hard Case for 6 Harps	\$151.05
SU-10HC-12	Diatonic Hard Case for 12 Harps	\$199.50
SU-SHC-6	Tremolo Hard Case for 6 Harps	\$151.05
SU-SHC-12	Tremolo Hard Case for 12 Harps	\$199.50

HARMONICA HOLDER



- Cushioned neck support
- Rubber holder for securing harmonica in place

Item#	Retail
SU-SHH-10R	\$56.85

MINI HARMONICAS



Necklace & Keychain Mini Harmonicas

Item#	Description	Retail
SU-N1200	Mini harmonica with necklace, 4 Holes, Range C3~C4	\$16.30
SU-K1200	Mini harmonica with keychain, 4 Holes, Range C3~C4	\$16.30



Minore Mini Harmonicas

- 5 Holes 10 Reeds
- Equipped with a keychain
- Made in Japan

Item#	Description	Retail
SU-MHK-5B	Black	\$20.65
SU-MHK-5R	Red	\$20.65
SU-MHK-5W	White	\$20.65

ACCESSORIES



Pitch Pipe

- Chromatic
- 13 Notes

Item#	Retail
SU-T171	\$36.95



Harmonica Slide Oil

- Cleans
- Reduces Noise

Item#	Retail
SU-SHO-01	\$23.05

Item#	Description	Retail
SU-CI-5	Harmonica Cable	\$52.45
SU-HRT-01	Harmonica Repair Tool Kit	\$102.95
SU-HRT-10	Harmonica Reed Tool Set	\$1092.95
SU-HKS-01	Key Stickers for Tremolo Harmonica	\$23.05
SU-HKS-02	Key Stickers for Diatonic Harmonica	\$23.05
SU-MIC-30	Microfibre Cloth	\$28.20

SUZUKI MELODIONS

ALTO MELODIONS

Study32

32 Keys, F~C³

Cover ABS
Reeds Phosphor Bronze
Accessories Short mouthpiece,
 Elastic Tube & Case

Item#	Colour	Retail
SU-STUDY32-BLK	Black	\$75.50
SU-STUDY32-PINK	Pink	\$75.50
SU-STUDY32-YELLOW	Yellow	\$75.50
SU-STUDY32-BLUE	Blue	\$75.50

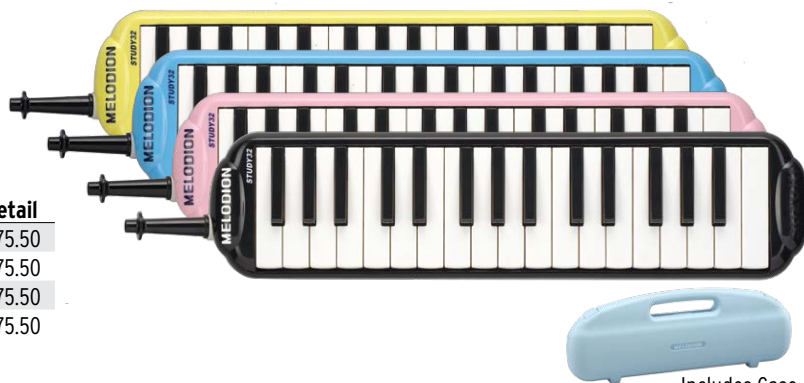

Includes Case

PRO-37V2

37 Keys, F~F³



Cover Aluminum
Reeds Phosphor Bronze
Accessories Short mouthpiece,
 Elastic Tube & Case

Item#	Retail
SU-PRO-37V2	\$366.85

M-37C

37 Keys, F~F³



Cover Aluminum
Reeds Phosphor Bronze
Accessories Short mouthpiece,
 Elastic Tube & Case

Item#	Retail
SU-M-37C	\$157.00

The HAMMOND

44 Keys, C~G³



Item#	Retail
SUH-PRO-44H	\$998.20

The first melodion that incorporates a built-in Dynamic Microphone, 44 note piano style keyboard, with a wider range from the lowest keyboard note C and ends at G³. Made with newly designed custom tapered reeds that offer a brighter and warmer sound.

The HAMMOND 44 HP

44 Keys, C~G³



Item#	Retail
SUH-HAM-44HP	\$1103.50

Incorporates a built-in pick-up microphone inside, which creates less mechanical noise compared to an external microphone and exceptional clear reed sound with H.D. Quality Sound reproduction. The HAMMOND 44 HP has a perforated Metal Cover, which allows a dry and bright sound from the reeds.

Key Features for the Hammond and Hamond 44 HP

- Phosphor Bronze Tapered Plated Reeds
- Brass plated Reedplates
- Standard 1/4" Phone Jack
- Internal Dynamic Lavalier Microphone
- Volume Controls
- Accessories: Short Mouthpiece, Flexible Mouthpiece, L-shape joint Long Mouthpiece, Cleaning Cloth and Gig bag.

M-37C Plus

37 Keys, F¹

- Cover** Metal
- Reeds** Phosphor Bronze
- Accessories** Flexible mouthpiece, & Padded bag

Item#	Retail
SU-M-37C-PLUS	\$196.35



Includes Padded Bag

MX-32CB

32 Keys, F~C

- Cover** Aluminum
- Reed** Phosphor Bronze
- Accessories** Short mouthpiece, Elastic Tube & Case

Item#	Retail
SU-MX-32CB	\$137.10



BASS MELODIONS

B-24

24 Keys, F~E¹

- Cover** ABS
- Reeds** Phosphor Bronze
- Accessories** Short mouthpiece, Elastic Tube & Case

Item#	Retail
SU-B-24	\$310.00



The HAMMOND BB

Electric-Acoustic Bass Melodion

24 Keys, F-e2

- Reeds: Phosphor bronze and Brass
- Reedplates: Brass plated
- Output Jack: Standard 1/4" Phone Jack
- 2 internal dynamic lavalieres
- Controls: Volume and Balance
- Accessories: Special Trombone-style Mouthpiece, L-shape joint Mouthpiece, Cleaning Cloth and Gig bag



Item#	Retail
SUH-HAM-BB	\$669.70

SOPRANO MELODIONS

MX-27S

27 Keys, G~A



- Cover** Aluminum
- Reeds** Phosphor Bronze
- Accessories** Short mouthpiece, Elastic Tube & Case

Item#	Retail
SU-MX-27S	\$110.50

OTHER MELODIONS

Andes 25F

Recorder/Keyboard

The world's first recorder/keyboard. This unique instrument allows you to play chords, unlike the traditional recorder.

Item#	Retail
SU-ANDES-25F	\$349.75



MELODION ACCESSORIES

Suzuki melodion mouthpieces are made from special materials which have anti-bacterial properties, and are, therefore, very hygienic.



Flexible Mouthpiece

Item#	Retail
SU-MP113	\$8.75



Short Mouthpiece

Item#	Retail
SU-MP121	\$4.35



Melodion Stand

Item#	Retail
SU-MST-01	\$99.35

BEAVERCREEK GUITARS

STEEL STRING

Body Top	Dreadnought Spruce	Back & Sides Neck	See product description Nato	Fingerboard/Bridge Machine Heads	Rosewood Diecast	Acoustic/Electric Model Additions	Body Electronics	Cutaway Active pickup & EQ w/Built-In Tuner
-----------------	--------------------	------------------------------	---------------------------------	---	---------------------	--	-------------------------	--



101 Series Dreadnought

Item#	Colour	Retail
BCTD101	Natural	\$235.00
BCTD101BK	Black	\$235.00
BCTD101BB	Blueburst	\$235.00
BCTD101RB	Redburst	\$235.00
NEW BCTD101VSB	Vintage Sunburst	\$235.00
Left-Handed		
BCTD101L	Natural	\$240.00
BCTD101LBK	Black	\$240.00
Acoustic/Electric		
BCTD101CE	Natural	\$320.00
NEW BCTD101CEVSB	Vintage Sunburst	\$320.00
Acoustic/Electric Left-Handed		
BCTD101LCE	Natural	\$325.00

Agathis Back & Sides



601 Series 3/4 Size

Item#	Colour	Retail
BCTD601	Natural	\$190.00
BCTD601BK	Black	\$190.00
BCTD601PK	Pink	\$190.00
BCTD601PBL	Pale Blue	\$190.00
NEW BCTD601VSB	Vintage Sunburst	\$190.00
BCTD601BB	Blueburst	\$190.00
BCTD601RB	Redburst	\$190.00
Left-Handed		
BCTD601L	Natural	\$195.00

Agathis Back & Sides



401 Series 1/2 Size

Item#	Colour	Retail
BCTD401	Natural	\$185.00
BCTD401PK	Pink	\$185.00
BCTD401BB	Blueburst	\$185.00
BCTD401RB	Redburst	\$185.00
Left-Handed		
BCTD401L	Natural	\$190.00

Agathis Back & Sides

BEAVERCREEK GUITARS



ALL **BEAVERCREEK** GUITARS ARE STRUNG WITH **D'ADDARIO EXP** STRINGS



101 Series Folk

Item#	Colour	Retail
BCTF101	Natural	\$235.00
BCTF101BK	Black	\$235.00
NEW BCTF101VSB	Vintage Sunburst	\$235.00
Left-Handed		
BCTF101L	Natural	\$240.00
Acoustic/Electric		
BCTF101CE	Natural	\$310.00

Agathis Back & Sides



NEW! 101 Series Parlor

Item#	Colour	Retail
BCTP101	Natural	\$235.00
BCTP101VSB	Vintage Sunburst	\$235.00



12 String Dreadnought

Item#	Colour	Retail
BCTV05	Natural	\$340.00
Left-Handed		
BCTV05L	Natural	\$345.00
Acoustic/Electric		
BCTV05CE	Natural	\$420.00

Mahogany Back & Sides

MIX & MATCH ANY 6 BEAVERCREEK INSTRUMENTS & \$AVE! Excludes Ukuleles

BEAVERCREEK GUITARS

TRAVEL SIZE

Body Top Scaled down travel size Roundback Spruce |
 Back & Sides Neck Agathis Nato |
 Fingerboard/Bridge Machine Heads Rosewood Chrome |
 Electronics Passive with V/T w/Built-in Tuner



Steel String Travel Size

Item#	Colour	Retail
BCRB501CE	Natural	\$310.00
BCRB501CEBK	Black	\$310.00
BCRB501CEBB	Blueburst	\$310.00
BCRB501CERB	Redburst	\$310.00
NEW BCRB501CEVSB	Vintage SB	\$310.00
Left-Handed		
BCRB501LCE	Natural	\$315.00

12-String Travel Size

Item#	Colour	Retail
BCRB501CE-12	Natural	\$365.00

Bass Travel Size

Item#	Colour	Retail
BCRB501CE-B04	Natural	\$420.00



Recommended Set
EXPPBB190GS

Classical Travel Size

Item#	Colour	Retail
BCRB501CE-C	Natural	\$320.00

MIX & MATCH ANY 6 BEAVERCREEK INSTRUMENTS & \$AVE! Excludes Ukuleles



ALL **BEAVERCREEK** GUITARS ARE STRUNG WITH **D'ADDARIO EXP STRINGS**

NYLON STRING

Body Classic | **Back & Sides** Agathis | **Fingerboard/Bridge** Rosewood **NEW** | Acoustic/Electric Model Additions
Top Spruce | **Neck** Nato | **Machine Heads** Chrome | **Body** Cutaway
Electronics Active pickup & EQ w/Buit-In Tuner



901 Series

Item#	Colour	Retail
BCTC901	Natural	\$205.00
BCTC901BB	Blueburst	\$205.00
BCTC901BK	Black	\$205.00
BCTC901RB	Redburst	\$205.00
Left-Handed		
BCTC901L	Natural	\$210.00
Acoustic/Electric		
BCTC901CE	Natural	\$280.00



601 Series 3/4 Size

Item#	Colour	Retail
BCTC601	Natural	\$190.00
BCTC601BB	Blueburst	\$190.00
BCTC601PK	Pink	\$190.00
BCTC601RB	Redburst	\$190.00
Left Handed		
BCTC601L	Natural	\$195.00



401 Series 1/2 Size

Item#	Colour	Retail
BCTC401	Natural	\$185.00
BCTC401BB	Blueburst	\$185.00
BCTC401PK	Pink	\$185.00
BCTC401RB	Redburst	\$185.00

OTHER INSTRUMENTS



Crossover (Guitar/Ukulele)

Item#	Retail
BCGL18	\$230.00

Top	Spruce
Back & Sides	Zebra wood
Neck	Nato
Fingerboard/Bridge	Rosewood
Machine Heads	3-In-Line Gold



Acoustic Bass

Item#	Colour	Retail
BCB05CE	Natural	\$515.00
BCB05CEVSB	Vintage Sunburst	\$515.00
Left-Handed		
BCB05LCE	Natural	\$520.00

Zebra Wood Back & Sides

BLUEGRASS



Mandolin

Item#	Retail
BCMM201	\$243.00
Left-Handed	
BCMM201L	\$250.00
Acoustic/Electric	
BCMM201E	\$305.00

Body	Spruce
Back & Sides	Maple Multiple binding
Neck	Nato
Fingerboard	Rosewood
Machine Heads	Chrome

Acoustic/Electric Model Additions

Electronics Active pickup & EQ

MIX & MATCH ANY 6 BEAVERCREEK INSTRUMENTS & \$SAVE! Excludes Ukuleles

UPGRADES



Banjo

Item#	Description	Retail
BCBJC18	18 Bracket	\$322.00
Left-Handed		
BCBJC18L	18 Bracket	\$332.00



Banjo/Guitar - 6 String

Item#	Description	Retail
BCBJ-G	30 Bracket	\$370.00

BeaverCreek
BANJOS

Body	Mahogany Resonator
Top	Remo Head
Back & Sides	Mahogany
Neck	Nato
Fingerboard	Rosewood
Rim	Aluminum
Arm Rest	Chrome plated
Machine Heads	Chrome

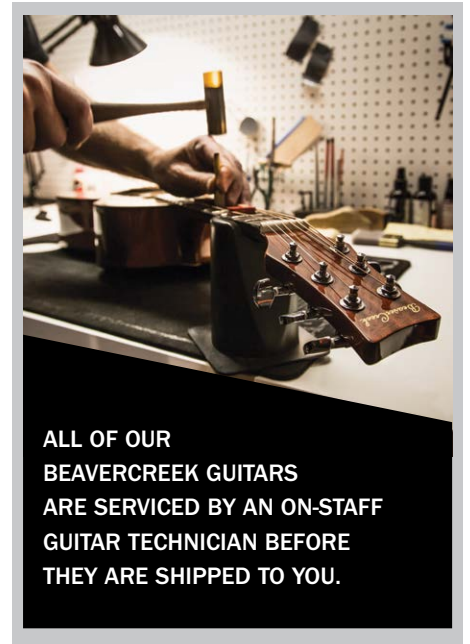

ALL OF OUR
BEAVERCREEK GUITARS
ARE SERVICED BY AN ON-STAFF
GUITAR TECHNICIAN BEFORE
THEY ARE SHIPPED TO YOU.

BEAVERCREEK UKULELES

UKULELES



BAG INCLUDED

Mahogany Ukuleles

Item#	Type	Retail
BCUKE-S	Soprano	\$72.00
BCUKE-C	Concert	\$81.00
BCUKE-T	Tenor	\$90.00
BCUKE-B	Baritone	\$97.00

Acoustic/Electric

NEW BCUKEE-S	Soprano	\$72.00
NEW BCUKEE-C	Concert	\$81.00
NEW BCUKEE-T	Tenor	\$90.00
NEW BCUKEE-B	Baritone	\$97.00

Body	See above
Top	Mahogany
Back & Sides	Mahogany
Neck	Nato
Fingerboard/Bridge	Rosewood
Machine Heads	Diecast



PADDED BAG INCLUDED

Solid Top Rock Ukulele

Item#	Back/Sides	Retail
BCUKE-CE-10V	Zebra wood	\$345.00

Body	Rock Uke
Top	Solid Sitka Spruce
Back & Sides	see table above
Neck	Mahogany
Fingerboard/Bridge	Rosewood
Machine Heads	Diecast
Electronics	Active Pickup



PADDED BAG INCLUDED

Solid Top Ukulele

Item#	Retail
BCUKE-S5	\$177.00

Body	Soprano
Top	Solid Mahogany
Back & Sides	Solid Mahogany
Neck	Nato
Fingerboard/Bridge	Rosewood
Machine Heads	Diecast

MIX & MATCH ANY 6 BEAVERCREEK UKULELES & SAVE!

ULINA UKULELES

with Matte Finish



Item#	Colour	Retail
NEW BCABS-WOOD	Wood Finish	\$51.50
NEW BCABS-CAM01	Camouflage	\$51.50
BCABS-GREEN	Green	\$51.50
BCABS-BLUE	Blue	\$51.50
BCABS-BLACK	Black	\$51.50
BCABS-PURPLE	Purple	\$51.50
BCABS-PINK	Pink	\$51.50
BCABS-RED	Red	\$51.50
BCABS-WHITE	White	\$51.50
BCABS-ORANGE	Orange	\$51.50
BCABS-YELLOW	Yellow	\$51.50
NEW BCABS-METAL	Metal	\$51.50
NEW BCABS-BABYBLUE	Baby Blue	\$51.50

- Impervious to weather
- Maintenance free (no sharp frets, no setup, no paint flaws)
- Easy to clean
- Warm sound
- Includes Bag

NEW! ACOUSTIC AMPLIFIERS



- Acoustic 5W amp
- Battery powered with optional 9V
- Headphone input
- Aux input



- Acoustic 20W / 40W amp
- XLR input
- Spring reverb and chorus
- Speaker stand port

Item #	Description	Retail
BCAMP-5A	Acoustic Amp 5W	\$90.00

Item #	Description	Retail
BCAMP-20A	Acoustic Amp 20W	\$240.00
BCAMP-40A	Acoustic Amp 40W	\$349.00

TUNE-BOT & TYPHOON AMPS

Tune-bot Electronic Drum Tuner

To measure the pitch of your drum, just clip the device to the drum hoop and hit the drum. It's that simple. To measure the pitch of individual lugs, just hit the drum next to the lug as you would if tuning by ear. The device automatically filters out overtones and gives you a consistent and accurate reading in Hz or musical notes.

GIG



- Overall (fundamental) pitch measurement
- Lug to lug pitch measurement
- Simplified for ease of use (2 button design)
- Redesigned clip



Item#	Retail
TUNE-BOT-GIG	\$125.00

STUDIO



- Measure pitch as frequency and note
- Tune whole kits in musical intervals
- Match lug pitches to fine-tune
- Difference Mode for easier matching
- Filter Mode to avoid false reading
- Standard & High pitch ranges



Item#	Retail
TUNE-BOT-TB001	\$179.00

TYPHOON AMPLIFIERS



A



B



Item#	Description	Retail
A TYAMP-10G	<ul style="list-style-type: none"> • 10 watts • Overdrive switch • 3 band EQ 	\$110.00
B TYAMP-20GR	<ul style="list-style-type: none"> • 20 watts • 10" Speaker - Celestion • Reverb • 3 band EQ • Overdrive switch 	\$200.00
C TYAMP-20B	<ul style="list-style-type: none"> • 20 watts • 2 inputs • 4 band EQ • CD line input • Headphone input • External speaker output • Carpet Finish 	\$165.00

ACOUSTIC SOUNDHOLE PICKUPS



PanaFlex Wireless System

- Stereo panorama Nanoflex undersaddle pickup
- Panorama control - set output mono or panorama stereo
- BT/B bass treble control for upper 3 strings and lower 3 strings
- Master volume control, Wireless on/off & Chromatic tuner
- 5.2GHz transmission
- Fits all soundholes
- Includes receiver, AC/DC power adapter, USB charge connector, USB cable &, bridge undersaddle pickup & a set of hex saddles

Item#	Description	Retail
SH-PFA-W	Acoustic Wireless System	\$725.30
SH-PFC-W	Classic Wireless System	\$725.30
SH-PF-A	Acoustic Pickup only	\$435.20
SH-PF-C	Classic Pickup only	\$435.20



PanaMag Wireless System

- Stereo panorama NanoMAG pickup
- Panorama control - set output mono or panorama stereo
- BT/B bass treble control for upper 3 strings and lower 3 strings
- Master volume control, Wireless on/off & Chromatic tuner
- 5.2GHz transmission
- Fits all soundholes
- Includes receiver, AC/DC power adapter, USB charge connector, USB cable & stereo hex NanoMAG pickup

Item#	Description	Retail
SH-PMG-W	Acoustic Wireless System	\$725.30



Single Coil Soundhole Pickup

Magnetic Single Coil

Quick mount soundhole magnetic pickup. This well shielded single coil pickup in a maple wood case with natural finish is vacuum waxed and sealed in epoxy with a fixed 4m noiseless cable. Easy to install, detached at any time, and can be rotated in the soundhole.

Item#	Retail
SH330	\$112.80



Active Soundhole Pickup with Volume Control

A Perfectly balanced output providing a clear and crisp sound with zero hum. Features an endpin connector and a separate output cable (12 foot) included.

Item#	Description	Retail
SH145B	Black	\$274.10
SH145G	Gold	\$274.10

ENDPIN PREAMPS



Item#	Description	Retail
SH-NMG-EP	NanoMag for Acoustic Guitar	\$257.90
SH-NFX-EPA	Nanoflex for Acoustic Guitar	\$225.70

Undersaddle Nanoflex Pickup With Endpin Preamp For Ukulele

Provides singing, soft trebles and smooth bass. Output avoids any distortion, excludes overload and provides clear, natural sound.



Item#	Retail
SH-NFX-EPU	\$209.50

ACOUSTIC & CLASSICAL PIEZO PICKUPS

Quick Mount Classical Pickup

If you are looking for a low cost undersaddle pickup we recommend Shadow's piezo pickups. They are easy to install without major modifications to the instrument. Because they are passive they do not require a battery.

Item#	Description	Retail
SH099	Undersaddle bridge pickup for acoustic and classical guitar	\$96.70

ACOUSTIC TRANSDUCERS



Transducers are a popular and simple way to amplify your instrument as they are applicable for all types of acoustic instruments. The sensors mount easily on the instrument's resonance body with the supplied adhesive tape. The sound characteristics depend strongly on the placement of the transducer on the instrument. Depending upon preference

and taste you can alter the sound characteristics by trying the transducer in different areas of the instrument. No modification on instrument needed!

Item#	Description	Retail
SH712	Twinducer with 1/4" socket	\$90.30
SH720	Twin small spot transducer with 1/4" socket	\$90.30
SH711	Singleducer with 1/4" socket	\$64.50
SH710	Small spot transducer with 1/4" socket	\$64.50

UKULELE PICKUPS

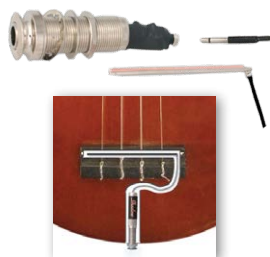

Undersaddle Pickup With Endpin

The SH 1110-UK is a complete pickup system to amplify your acoustic ukulele. It consists an undersaddle pickup, fitting all standard slots and guaranteeing balanced volume among all your instrument's strings.

Item#	Retail
SH1110-UK	\$96.70



Nanoflex Pickup With Preamp

Mounts under the bridge saddle and the attached extremely light preamp with 3V cell battery holder, volume control and output socket mounts to the bridge end.

Item#	Retail
SH-NFX-UK	\$241.80

MANDOLIN & BANJO PICKUPS



Pickup / Bridge

For Mandolin

Height adjustable arch top mandolin bridge (solid ebony base).

Item#	Description	Retail
SH925	Arch Top Mandolin Bridge	\$195.00
SH926	w/ Pickup - V/T control & 4m cable	\$240.20



Transducer

For Banjo

Banjo transducer with socket.

Item#	Retail
SH-B1	\$104.80



Pickup / Bridge

For Banjo

Five string banjo bridge with built in pickup. Pickup features V/T controls. Includes a 4m cable.

Item#	Description	Retail
SH930	5- String Banjo	\$170.80
SH930T	4- String Banjo	\$170.80

VIOLIN PIEZO PICKUPS



Violin Bridge

with Built-in Pickup

High quality maple violin bridge has piezo pickup mounted in center. Includes "chin rest" style volume / tone controls.

Item#	Retail
SH940	\$190.20



Twin Bridge Pickups

Sensors mount between the bridge wings and feet. Features an attached output socket.

Item#	Retail
SH941	\$174.10



Violin Transducer

with Volume Control

Includes volume & tone controls. Transducer mounts directly to the bridge with adhesive. Includes "chin rest" style volume / tone controls.

Item#	Retail
SH3000	\$153.10



Violin Transducer

Has a sensor mount between the wings and feet of the bridge and body. Includes an attached 6.3mm 1/4" socket.

Item#	Description	Retail
SHSV1	Violin Transducer	\$59.60
SHSV2	Twin Violin Transducer	\$104.80

VIOLIN NANOFLEX PICKUP



NanoFlex Pickup With Preamp

A professional violin pickup which provides absolute natural sound with "0" hum. No modification on instrument needed. Nanoflex pickup with preamp for violin.

Item#	Retail
SH945-NFX	\$257.90

OTHER PRODUCTS

Stompin' Bass

Works as a fantastic bass or bass drum accompaniment to an acoustic band.

Item#	Retail
SH-STOMPIN	\$241.80



UPRIGHT BASS & CELLO PICKUPS

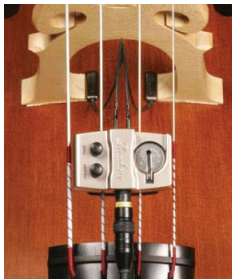

Nanoflex Pickup With Preamp

For Upright Bass / Cello

Mounts easily between the two middle strings and has volume and tone controls. It is powered by a single 3V cell battery with extremely low power consumption. The system is absolutely noise and hum-free.

Item#	Description	Retail
SH955-NFX	For Cello	\$306.30
SH965-NFX	For Upright Bass	\$354.60

Kill Pot

Unique potentiometer with a momentary push switch for electric guitars, which momentarily kills the sound by stroking it up and down. By pushing it up and down quickly it creates an extraordinary machine gun sound effect with your guitar. Preserves your toggle switch.



Item#	Description	Retail
SH124-25	25kOhm resistance for active pickups	\$35.50
SH124-250	250kOhm resistance for single coil pickups	\$35.50
SH124-500	500kOhm resistance for humbucker pickups	\$35.50



Bridge Pickup

For Upright Bass

Four sensors produce a natural sound when either plucked or bowed. Two opposing sensors per side.

Item#	Description	Retail
SH950	Double Side	\$277.30
SH951	Single Side	\$164.40



Transducer

For Upright Bass

Sensors mount between the wings and feet of the bridge. Includes an attached 6.3mm, 1/4" socket.

Item#	Description	Retail
SH-SB1	Upright Bass	\$59.60
SH-SB2	Twin Upright Bass	\$104.80

Endpin Jacks

Item#	Description	Retail
A SH012-C	Endpin jack for acoustic guitar 1/8" input and 1/4" output	\$40.30
B SH010	Stereo endpin jack for acoustic guitar	\$33.70



For a complete list of Shadow products visit

www.shadow-electronics.com

or contact your sales representative

1-800-268-6855 or orders@daddariocanada.com

VIOLIN OUTFITS



Includes:

- Oblong case
- Brasil wood bow
- D'Addario natural rosin



- Solid wood spruce top
- Maple back with printed flame
- Ebony finger board
- Metal alloy tailpiece with four fine tuning
- Strung with D'Addario Orchestral Strings
- Chin rest and pegs are made from solid wood similar to ebony
- Available in 4/4, 3/4, 1/2 & 1/4

Violin Outfits

Item#	Size	Retail
ZEV-VLN44	4/4	\$295.70
ZEV-VLN34	3/4	\$295.70
ZEV-VLN12	1/2	\$295.70
ZEV-VLN14	1/4	\$295.70

NEW! Violin Bows

Item#	Size	Retail
ZEV-BOW44	4/4	\$31.10
ZEV-BOW34	3/4	\$31.10
ZEV-BOW12	1/2	\$31.10
ZEV-BOW14	1/4	\$31.10

RECORDERS

- 3 piece made of ABS plastic
- Includes an attractive bag with a cleaning rod & finger chart
- Comes in boxes of 100

Item#	Description	Retail
ZEV-PR-B	Baroque (English) Fingering	\$4.95
ZEV-PR-G	German Fingering	\$4.95



ENERGIZER BATTERIES



Energizer Max AA Batteries

Item#	Description
EN-E91BP4	AA 4/card
24 CARDS/BOX	



Energizer Max AAA Batteries

Item#	Description
EN-E92BP2	AAA 2/card
18 CARDS/BOX	



Energizer Max 9V Batteries

Item#	Description
EN-522BP	9V 1/card
12 CARDS/BOX	

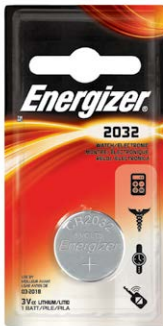

Energizer Cell Batteries

Item#	Description
EN-ECR2032BP	CR2032 1/card
EN-ECR2430BP	CR2430 1/card Fits the PW-HTS
6 CARDS/BOX	



7 LED Headlight

Item#	Description
EN-HDC32E	Light w/3 AAA Alkaline Batteries



LED Clip Light

Item#	Description
EN-FNL2BU1BP	Light w/2 CR2032



Energizer 9V Industrial Batteries

Item#	Description
EN-EN22	9V Box/12pcs



Energizer AA Industrial Batteries

Item#	Description
EN-EN91	AA Box/24pc



Energizer AAA Industrial Batteries

Item#	Description
EN-EN92	AAA Box/24pc

CALL 1-800-268-6855 FOR PRICING

INSTRUMENT SERIES

Supremo Series

- Ideal for beginners and percussion enthusiasts
- Black powder-coated Deluxe hoops, reinforced side plates

Item#	Description	Retail
BONGOS		
STB-B BK	Black - 7" & 8.5"	\$189.40
STB-B BN	Natural - 7" & 8.5"	\$189.40
STB-B BR	Red - 7" & 8.5"	\$189.40
CONGAS		
STC-B BK/D	10" & 11" Set - Black w/double stand	\$796.05
STC-B N/D	10" & 11" Set - Natural w/double stand	\$796.05
STC-B R/D	10" & 11" Set - Red w/double stand	\$796.05
DJEMBES		
TJS-72 B N	12" Natural	\$373.15
CAJONS		
STK-29	29cm	\$241.50

available colours

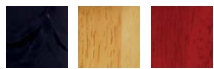

Artist Series

- Ideal for the working percussionist
- Constructed of hand-selected aged Siam Oak wood
- Applied with super high-gloss finishing

Item#	Description	Retail
BONGOS		
TB-80 B HP RE	7" & 8.5"	\$231.95
CONGAS		
TC-91 B HP RE/D	10" & 11" Set w/double stand	\$894.70
DJEMBES		
TJ-70 B HP RE	10"	\$393.70
TJ-72 B HP RE	12"	\$494.75
CAJONS		
TKRE-29	29cm	\$383.90



Master Handcrafted Pinstripe Series

- Handcarved by highly-skilled craftsmen
- Constructed of hand-selected aged Siam Oak wood
- Antique copper deluxe hoops (where applicable)

Item#	Description	Retail
BONGOS		
MTBHC-800 AC T1	7" & 8.5"	\$434.40
CONGAS		
MTCHC-110 AC T1/S	11" Quinto w/Stand	\$1005.40
MTCHC-120 AC T1/S	11 3/4" Conga w/Stand	\$1097.75
MTCHC-130 AC T1/S	12 1/2" Tumba w/Stand	\$1176.95
DJEMBES		
MTJHC-712 AC T1	12"	\$786.15
MTJHC-713 AC T1	13"	\$917.10
CAJONS		
TKHC-29 T1	29cm	\$433.90



CAJONS

Made from excellent sounding durable hardwoods. Individually hand made and tested to ensure superior sound quality. Deep, loud bass and high sharp slap tones. Adjustable snare wires and allen wrench included.



Item#	Model	Description	Retail
A STK-29	SUPREMO SERIES	Front Plate-Asian Hardwood / Body-Siam Oak	\$241.50
B STKS-29DI	SUPREMO SELECT SERIES	Front Plate-Asian Hardwood / Body-Siam Oak	\$264.25
C TKE-29	BOX	Front Plate-Ebony / Body-Siam Oak	\$368.30
D TKT-29	BOX	Front Plate-American White Ash / Body-Wood Mixture Front	\$406.25
E TK-35	35cm HARDWOOD	Front Plate-Asian Hardwood / Body-Siam Oak	\$365.05
E TK-29	29cm HARDWOOD	Front Plate-Asian Hardwood / Body-Siam Oak	\$317.05
F TKCT-29	CRATE	Front Plate-Siam Oak / Body-Siam Oak	\$383.90
G TKRE-29	ARTIST RETRO	Front Plate-Siam Oak / Body-Siam Oak	\$383.90
H TKHC-29 T1	HANDCRAFTED PINSTRIPE	Front Plate-Siam Oak / Body-Siam Oak	\$433.90
I TK30CSC-29	30TH ANNIVERSARY	Front Plate-American Ash / Body-American White Ash	\$553.70
NEW J STKS-29 TW	SUPREMO SELECT TWILIGHT SERIES		\$264.25

Roundback Cajon

- A curved back panel with the sound port located on the side providing enhanced tonal qualities
- Black Makah Burl front plate, Siam Oak body
- Features adjustable snare wire



Item#	Retail
TKRB-29 BMB	\$505.10

DOHC Cajon

- Body and front plate constructed of hand-selected environmentally-friendly Siam Oak wood
- This unique cajon contains 2 separate chambers and sound holes, providing a versatile combination of deep, traditional bass sounds and crisp, tight, snare slaps
- Features adjustable snare wire



Item#	Retail
TKDOHC-32	\$648.90
TKDOHC-35	\$706.55

Triple-Play Cajon

- 3 distinct playing surfaces each producing different sounds
- Front (middle) - Constructed of premium Beech Wood and features no screws.
- Left - Dark ebony and is equipped with snares to play and sound like most traditional cajons
- Right - Red Oak front plate with no snare, and plays much like our popular Criollo Cajon with a traditional Peruvian sound and feel



Item#	Description	Retail
TK3PC-29	29cm	\$721.35
TK3PC-35	35cm	\$811.30

Vertex Series Cajon

- Combines the crisp, sharp slaps of our 29 Series, with deep, booming bass tones of our 35 Series cajons
- Unique pyramid shape designed for improved ergonomics and comfort
- Features adjustable snare wire



A



B

Item#	Description	Retail
A TKVX-G	North America white ash front plate with red oak body	\$611.55
B TKVX-Z	Ash body and Zebrawood front plate	\$611.55

Portable Cajon

- Designed to be ultra-light weight and portable at only 0.75 kg
- Body is made using solid Siam Oak Wood, 30cm x 40cm on the playing surface and only 5cm thick
- A premium Beech Wood frontplate for optimal response
- Equipped with a specially-treated non-slip pad at the bottom
- Efficiently designed handle built in to enhance movability

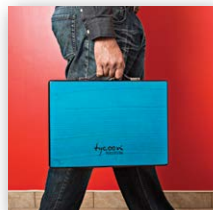

Item#	Retail
TK-PCPP	\$177.55

BONGOS



Ritmo Series Bongos

- Perfect for novice bongo players
- 6" & 7" shells constructed of hand-selected aged Siam Oak and Jamjuree wood
- Black powder-coated Classic-Pro hoops

Item#	Description	Retail
TB-8 B BL	Blue	\$133.10
TB-8 B M	Mahogany	\$133.10
TB-8 B BR	Brown	\$133.10
TB-8 B BN	Natural	\$133.10
TB-8 B R	Red	\$133.10
TB-8 B BK	Black	\$133.10
NEW TB-8 B JM	Jamjuree	\$133.10

available colours



CONGAS

Junior Congas

- 15" tall, constructed of hand-selected aged Siam Oak wood
- 8" & 9" set
- High-gloss finish
- Stand included



Item#	Retail
TCJ-B N/D	\$514.70

DJEMBES

Fiberglass Tuneable Djembes

- Lightweight
- Hand picked quality goat skin head
- Mock natural finish
- Sharp slap notes and loud sound



Item #	Description	Retail
TFJ-10 K	10" head / 19" tall - Kente	\$209.15
TFJ-12 K	12" head / 24" tall - Kente	\$247.70



African Djembes

- Handcrafted from a single piece of sun-dried Mango Wood
- Deep, loud bass tones & high, sharp slap tones
- 5mm extra strong non-stretch rope for easy and lasting tuning
- Natural varnish finishing

Item#	Size	Retail
TAJ-6	6" head / 10" tall	\$126.00
TAJ-8	8" head / 16" tall	\$190.30
TAJ-10	10" head / 19" tall	\$263.70
TAJ-12	12" head / 24" tall	\$309.60

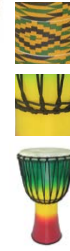

Fiberglass African Djembes

- Lightweight
- Hand picked quality goat skin head
- Mock natural finish
- Sharp slap notes and loud sound

Item#	Size	Retail
TFAJ-10	10" head / 19" tall	\$196.45
TFAJ-12	12" head / 24" tall	\$232.85
NEW TFAJ-10 JC	10" head / 19" tall - JC	\$196.45
NEW TFAJ-12 JC	12" head / 24" tall - JC	\$232.85
NEW TFAJ-10 K	10" head / 19" tall - Kente	\$196.45
NEW TFAJ-12 K	12" head / 24" tall - Kente	\$232.85

BAGS

Offers the best protection available in a convenient carrying case. Made of high-strength nylon, it has an adjustable shoulder strap, a handle, and an outer pocket. The distinct yellow colour stands out from the crowd.

Item#	Description	Retail
A TBPB	Bongo Professional Bag	\$106.00
B TCPB-S	Conga Small Professional Bag (fits Tycoon 10" Requintos and 11" Quintos)	\$166.15
B TCPB-L	Conga Large Professional Bag (fits Tycoon 11.75" Congas and 12.5" Tumbas)	\$192.70
C TJPB	Djembe Professional Bag	\$157.80
D TKBB-29	Cajon Deluxe 29cm Bag	\$112.45
D TKBB-35	Cajon Deluxe 35cm Cajon Bag	\$134.35
E TKPB-29	Cajon Professional 29cm Bag	\$141.30
E TKPB-35	Cajon Professional 35cm Bag	\$157.85
F TKBP-29	Cajon Deluxe 29cm Bag Backpack	\$63.05



STANDS

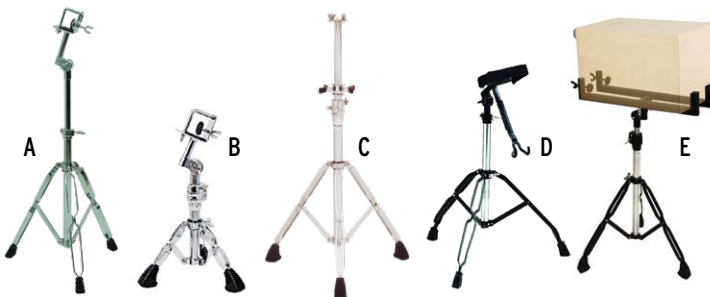

Item#	Description	Retail
A TBS-C	Bongo - Chrome	\$217.80
NEW B TBSS-C	Bongo Stand for Seated Player Chrome	\$189.35
TCD-B	Double Conga Stand - Black	\$145.00
C TCD-C	Double Conga Stand - Chrome	\$155.95
D TJS-B	Djembe - Chrome Stand /Black Legs	\$260.75
E TKS-B	Cajon - Chrome Stand /Black Legs	\$319.95

ACCESSORIES

Rubber Conga Protector



Item#	Retail
CP	\$6.00

Djembe Harness



Item#	Retail
TJAS-HS	\$60.05

ETHNIC DRUMS

Batas

- Made from sustainably-harvested Siam Oak wood
- Premium quality water buffalo skin heads
- Chrome plated hardware
- Accessory pouch with tuning wrench and lug lube included

Item#	Description	Retail
TBA-OKO	Small Bata Drum - Okonkolo	\$645.20
TBA-ITO	Medium Bata Drum - Itotele	\$717.85
TBA-IYA	Large Bata Drum - Iya	\$829.25



Klong Yaw

- Handcrafted from a single piece of hardwood
- Uniquely long and narrow shell enhances the bass tones of this instrument
- Extra strong tension ropes for easy and long-lasting tuning

Item#	Description	Retail
EKY	9" head / 30" tall	\$267.95



Doumbeks

- Choice of aluminum or copper models
- Durable synthetic head
- Crisp sound with optimum resonance

Item#	Description	Retail
A TDO-ECO	Egyptian Copper - 8.7" head / 17.3" tall	\$317.30
B TDO-EBK	Egyptian Black - 8.7" head / 17.3" tall	\$309.35
C TDO-KR203	Egyptian Antique - 8.7" head / 17.3" tall	\$529.35



A

B

C

Ngoma Drum

- Tycoons version of the traditional West African Drum
- Uniquely long and narrow shell enhances the bass tones of this instrument
- Extra strong tension ropes for easy and long-lasting tuning

Item#	Description	Retail
TDD-NGD SI	13" head / 42" tall	\$665.10

Stand available as additional option



Frame Drums

- Frame Drums of Irish descent
- Constructed with Siam Oak wood
- Natural goatskin head
- Wooden tipper (included)

Item#	Description	Retail
TBFD-16	16" frame drum	\$157.55
TBFD-18	18" frame drum	\$181.50



Darbuka with Built-In Tambourine

- Goblet drums from ancient origin
- Choice of aluminum or copper models
- Gives a wide spectrum of sound
- Crisp sound with optimum resonance

Item#	Description	Retail
TDA-ALP	8.5" head / 14.5" tall	\$144.80



NEW! Aluminum Chocalho

- A traditional Brazilian rhythmic instrument
- Used to sustain the rhythm of the Surdos or Repinique
- Constructed of lightweight steel
- Features 45 aluminum jingles across 5 rows

Item#	Retail
TPCH	\$280.85



TIMBALES

6" & 8" Mini Timbales

- Chrome-plated steel shells provide brighter, but excellent sounding cascara
- Easily mountable onto any percussion or drum kit
- Tunable using a tuning wrench (included)



Item#	Description	Retail
TTI-68 C	6" & 8"	\$401.80



Shell Timbales

- Superior quality and authenticity in sound designed for the professional or advanced player
- Antique Shells are made from stainless steel, and can be tuned with a tuning wrench
- 14" & 15" diameter, 6.5" deep

Item#	Description	Retail
TTI-1415 C	14" & 15"	\$745.95

Ralph Irizarry Signature Series

- Designed in collaboration with master timbalero Ralph Irizarry
- Unique black satin finish, featuring Ralph's signature nameplate
- 14" & 15" diameter chrome-plated shells are made from stainless steel
- Includes heavy duty, fully height-adjustable, tilting timbale stand, cowbell mounting bracket, Tycoon TW-60 cowbell, pair of timbale sticks, and tuning wrench



Item#	Retail
TTI-1415 RISS	\$803.15

Black Powder Coated Timbales

- Superior quality and authenticity in sound designed for the professional or advanced player
- Shells available in standard depth (6" tall), deep-shell (8" tall), and extradeep shell (10" tall)
- Includes heavy duty, fully height-adjustable, tilting timbale stand, cowbell mounting bracket with Tycoon TW-60 cowbell, pair of timbale sticks, and tuning wrench



Item#	Description	Retail
TTI-1314 B	13" & 14"	\$674.55

TAMBOURINES

Plastic Tambourines

- Chrome plated steel alloy jingles deliver crisp cutting sounds
- Frame constructed of high-strength plastic for added durability



Item#	Description	Retail
TBH-B BS	Hand-Held (Black)	\$70.25
TBD-B S	Mountable	\$95.70
TBH-R BS	Hand-Held Bright Sound (Red)	\$70.25

Hi-Hat Tambourine

- Versatile tambourines designed for mounting on Hi-hat pull rods
- Lightweight and small diameter
- Constructed from an all-steel frame



Item#	Description	Retail
TBHH-5 S	5 Pair Steel Jingles	\$38.65
NEW TBHH-10 S	10 Pair Steel Jingles	\$54.60
NEW TBHH-10 B	10 Pair Brass Jingles	\$65.80

Wooden Moon Tambourine

- This tambourine features chrome plated steel alloy jingles that deliver crisp cutting sounds
- Constructed of environmentally friendly siam oak wood.



Item#	Retail
TBM	\$53.60

Wooden Single Row Headed

A single headed single row tambourine, designed for greater playability in all musical situations. With Premium quality goat skin head. The Bright Steel Chrome-plated alloy jingles deliver crisp, cutting sounds.



Item#	Retail
TBWH-S BS	\$62.55

FINGER CYMBALS

Produces a high-pitched ring, audible over an ensemble. Constructed of high quality brass. Include straps.

Item#	Description	Retail
THPFC	2"	\$36.05



JINGLE STICKS

Wooden Jingle Stick

Chrome plated steel alloy jingles deliver crisp cutting sounds. The frame is constructed of environmentally friendly Siam Oak Wood. Extremely lightweight and easily portable.



Item#	Description	Retail
TIT-B	Black Wooden	\$18.70
TIT-N	Natural Wooden	\$18.70
TIT-BR	Brown Wooden	\$18.70

Two-Tone Jingle Stick

This unique Jingle Stick brings out the characteristics of brass and steel jingles by alternately placing the rows. Simply rotate the stick towards you or away from you to choose which sounds you'd like to bring out. Made from environmentally friendly Siam Oak Wood. Blue Pearl finish.



Item#	Retail
TTJS	\$50.55

SHEKERES

A fibreglass shekere, hand strung plastic with beads woven in an adjustable nylon web allows for playing both loud, rattling sounds or softer sounds with added control. Excellent drum-like bass tones created from hitting the bottom of the shell. Protective rubber ring covers the mouth of the shekere.



Item#	Description	Retail
TSKS-B	Small (8" diameter)	\$173.65
TSK-B	Large (10" diameter)	\$335.90

CABASAS

Constructed with a ridged stainless steel shell surrounded by loops of steel-bead chains. Wooden flanges enclose the steel cylinder with a wooden handle attached to the bottom.



Item#	Retail
TSA-M BR	\$87.80

CLAVES

Wood Claves

Crafted from exotic Asian hardwood. 10" long, the Clave and Striker are the same size. Moderately pitched clicking sounds when struck against one another.

Item#	Description	Retail
TVW-8	8" Wood	\$19.80
TVW-10	10" Wood	\$22.35

Sold in pairs



10" Rosewood Claves

Crafted from rosewood for added durability. 10" long, the Clave and Striker are the same size. Bright clicking tones by striking the beater against the clave.

Item#	Description	Retail
TVW-L	10" Rosewood	\$67.40





RESPONSIBLE RENEWABLE RESOURCE



100% Plantation Farmed Wood

In our rapidly changing world, every decision can make a difference for the future. That is why we are committed to using only certified, plantation-farmed Siam Oak wood in the production of our instruments. Renewed every 5-7 years, this carefully managed resource is easier on the environment than wood taken from old-growth forests. Finely crafted by hand in Thailand, these drums are a responsible choice for the future. Thank you for joining us in making the world a better place.

Welcome to the future!

BLOCKS

Woodblock

This highly durable wood block is made from environmentally friendly Siam Oak Wood. Steel mountable bracket included.

Item#	Retail
TDB-L	\$32.35



Temple Wood Blocks

Siam Oak block specially tuned to match the pitch of ancient temple blocks. Easily mounts on to any percussion or drum set up. Available in five sizes or as part of a complete set. Block beater and steel mountable bracket included.

Item#	Description	Retail
TWB-30	3"	\$36.95
TWB-35	3.5"	\$40.00
TWB-40	4"	\$43.00
TWB-45	4.5"	\$46.05
TWB-50	5"	\$49.05



Tempo Blocks

Created using specially formulated plastic. Combines the bright tones of traditional wood blocks with extra strength and durability. Mounting bracket included for an easy and quick set up in any musical setting. Available in a high-pitch and a low-pitch version with two distinct colours.

Item#	Description	Retail
A TTB-H	High (Yellow)	\$50.80
B TTB-L	Low (Red)	\$56.90
C TPPM	Block Mount	\$90.85

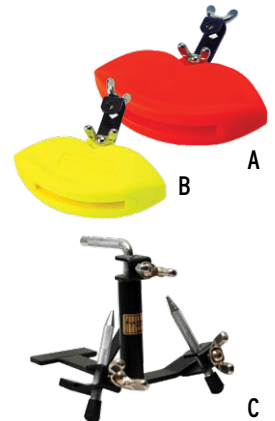

CASTANETS

Wooden Castanet

Crafted from environmentally friendly Siam Oak Wood. This versatile instrument is excellent for live playing, sound effects and unique sounds.

Item#	Retail
TNT	\$17.80



Wooden Castanet With Handle

Crafted from environmentally friendly Siam Oak Wood. Versatile instrument that is excellent for live playing. Wooden handle provided adds flexibility and playability.

Item#	Retail
TNT-H	\$23.90



TYCOON PERCUSSION

BELLS



Agogo

- Constructed of premium quality steel
- Larger bell combination delivers a lower-pitch drier sound, which contrasts nicely with the bright sounds of the smaller bell pairing
- Classic black powder coated finish
- Extremely durable, and portable

Item#	Retail
TGO-M	\$30.15



Tri Agogo

- Constructed of premium quality steel
- Larger bell combination delivers a lower-pitch drier sound, which contrasts nicely with the bright sounds of the smaller bell pairing
- Classic black powder coated finish
- Extremely durable, and portable

Item#	Retail
TGO-TRI	\$52.55



Cowbells

- Constructed of premium quality steel
- Clamps securely onto any cowbell holder with easy finger tightening
- Larger lower-pitched bells contrast nicely with smaller bells that produce brighter sounds
- Classic black powder coated finish

Item#	Size	Retail
TW-50	5"	\$34.00
TW-60	6"	\$42.55



Hand Hammered / Mountable Cowbells

Constructed of premium quality steel, these bells can clamp securely onto any cowbell holder with easy finger tightening. Larger lower-pitched bells contrast nicely with smaller bells that produce brighter sounds.

Item#	Size	Retail
TWH-50	5"	\$63.25
TWH-60	6"	\$76.65

Cowbell Beater

Straight dowel shape with rounded ends for playing comfort. Very durable, and has an excellent sound when playing live.

Item#	Description	Retail
TWL-B	Siam Oak Wood	\$8.10



Hand Held Cowbells

Constructed of premium quality steel. Clamps securely onto any cowbell holder with easy finger tightening. Larger lower-pitched bells contrast nicely with smaller bells that produce brighter sounds. Classic black powder coated finish.

Item#	Size	Retail
TWM-70	7"	\$64.30
TWM-85	8.5"	\$69.05
TWL	8.5" Low	\$72.30



Cowbell Dampeners

Works by dampening different parts of the Bell.

Item#	Description	Retail
TWCD-S	Small	\$4.05
TWCD-M	Medium	\$5.15
TWCD-L	Large	\$7.35



Black Pearl Series Mambo Bell

Constructed of premium quality steel. Rounded surface allows for easy playing and bright sounds.

Item#	Retail
TWT-B	\$42.95



Cha Cha Bell

Designed for mounted use, but is great for hand held playing as well, these bells deliver a clear, bright sound which complements any type of music. An excellent complement to our timbale bells, featuring a classic brushed chrome finish.

Item#	Retail
TWC-BC	\$54.85



Brushed Chrome Timbale Mambo Bell

Crafted from premium quality heavy gauge steel, these low-pitched bells deliver a drier sound, which harmoniously complements the brighter tones of our Cha-Cha bell. Great sound contrast between the mouth and back of bell. Perfect for live Salsa music situations.

Item#	Retail
TWT-BC	\$72.45

Sleigh Bells

Classic Sleigh Bell sound that can be heard over an ensemble. Traditional design. Constructed of Siam Oak wood handle with steel bells

Item#	Description	Retail
THPSB-2R	2 sided	\$35.80
THPSB-4R	4 sided	\$49.80



Energy Chimes

Crafted from tempered aluminum alloy producing bright sounds and excellent tonal diversity. Bar made from environmentally friendly Siam Oak Wood. Beater included.

Item#	Description	Retail
TEC-SC	Small	\$20.95
TEC-MC	Medium	\$22.95
TEC-LC	Large	\$25.15



CHIMES & TRIANGLES

Bar Chimes

Chimes crafted from tempered aluminum alloy, producing bright sounds and excellent tonal diversity. Storage slot for bar chime striker included in Siam Oak wooden bar.



Item#	Description	Retail
TIM-25 C BR	25 Tubes	\$142.05

Hand Chimes

12 chrome plated bars crafted from tempered aluminum alloy affixed in a circular formation to create bright jingling sounds. The bar is made from environmentally friendly Siam Oak Wood.

Item#	Description	Retail
TMC-12 C	Hand	\$54.20



Triangle

Chrome plated tempered steel delivers a bright, clean sound when struck with the striker. Matching steel striker and nylon hanging cord included.

Item#	Description	Retail
TRI-4	4"	\$20.40
TRI-6	6"	\$23.40
TRI-8	8"	\$27.15
TRI-10	10"	\$31.65



3 Gold-plated Chimes

Gold color plated bars crafted from tempered aluminum alloy, producing bright sounds and excellent tonal diversity. Bar made from environmentally friendly Siam Oak Wood.

Item#	Description	Retail
TEC-3G	3 Gold-plated Chimes	\$41.25



EFFECTS

Rainstick

- Creates rain-like sounds by tilting the stick
- Hand crafted from genuine bamboo
- Light weight and durable
- 60cm long

Item#	Description	Retail
TRS-60	60cm	\$69.60



Rattle Claps

- Sustained rattling sound created when ball is struck with the palm of the hand
- Excellent for sound effects and recordings

Item#	Description	Retail
TRC-H	High Pitch	\$60.10
TRC-L	Low Pitch	\$64.65

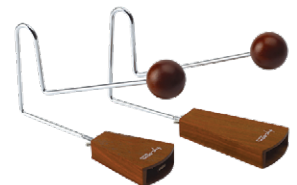

Frogs

Played by scraping the beater up and down the back of the frog, creating distinct "croaking" noises.

Item#	Description	Retail
TF-35	Small 3"	\$28.70
TF-40	Medium 4"	\$34.30
TF-60	Large 6"	\$49.20



Woodpecker

Played by shaking back and forth, creating a loud clatter sound. Made from Siam Oak wood.

Item#	Description	Retail
TWP		\$20.60



SHAKERS



Aluminum Shaker

Aluminum shell designed to produce crisp sounds ideal for live music.

Item#	Description	Retail
TAS-3	3" Chrome	\$31.60
TAS-8	8" Chrome	\$37.95

NEW! Wood Hexagon Shakers

Constructed from Jamjuree wood, designed to produce sharp, crisp sounds when maximum accuracy is required.



Item#	Description	Retail
TWHS-6	6"	\$37.15
TWHS-8	8"	\$43.90



Twin Shaker

Perfect for a soft or delicate sound. Great to use during recording sessions. Two individual shakers that can be easily separated for individual use.

Item#	Retail
TTS	\$30.20

Wood Shakers

Crafted from environmentally friendly Siam Oak Wood, these shakers are affixed with genuine water buffalo skin heads on both sides. Soft shake sounds when shaking sideways and louder sounds when fill strikes the skin head.



Item#	Description	Retail
TS-A	Bata	\$20.55
TS-B	Bongo	\$21.40
TS-C	Conga	\$18.10
TS-J	Djembe	\$18.10



Egg Shakers

Item#	Colour	Retail
TE-B	Blue	\$6.70
TE-G	Green	\$6.70
TE-O	Orange	\$6.70
TE-P	Pink	\$6.70
TE-Y	Yellow	\$6.70

Sold in pairs



Caxixi

Hand woven rattan shell with special fill produces a dry cutting sound. Woven handle and wooden fill cap.

Item#	Description	Retail
TXI-S	Small	\$24.30
TXI-L	Large	\$25.55



Wood Shakers

Constructed from environmentally friendly Siam Oak Wood, these are soft-sounding shakers.

Item#	Description	Retail
TWS-M	Triangle	\$20.60
TDS-M	Dice	\$28.20



Round Wood Shaker

Siam Oak shells deliver soft, warm sounds and great control. 4" rounded shells for ease in playing.

Item#	Retail
TS-40	\$19.85

Sold in pairs



Guiro Wood Shaker

Versatile instrument that is a hybrid between a guiro and a wooden soft sounding shaker. Wooden scraper included.

Item#	Retail
TGS-W	\$23.30

MARACAS

Rawhide Maracas

Natural rawhide shells with wooden handles, and feature new fill material specially designed to produce crisp, tight sounds.



Item#	Description	Retail
TMS-60	Skin - Small	\$35.85
TMS-70	Skin - Med	\$45.25

Sold in pairs

Beaded Maracas

Made from durable plastic shells and wooden handles. These maracas can also be used as a Shekere effect!

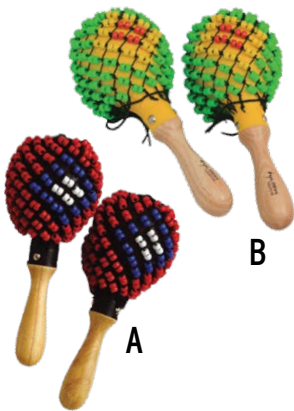

Item#	Description	Retail
A TMPB-B	Beaded Blue & Red	\$49.90
B TMPB-Y	Beaded Yellow	\$49.90

Sold in pairs

Plastic Maracas

Durable plastic shells and wooden handles. Ideal for recreational gatherings, drum circles, or just having fun.



Item#	Description	Retail
A TMP-B	Black	\$28.90
B TMP-Y	Yellow	\$28.90
C TMPS-BL	Blue (Higher tones)	\$24.95
D TMPS-R	Red (Lower sounds)	\$24.95

NEW

NEW

Sold in pairs

Wood Maracas

Item#	Description	Retail
A TMW-N	Wood	\$50.40
B TMW-M	Wood - Mini	\$22.10

Sold in pairs

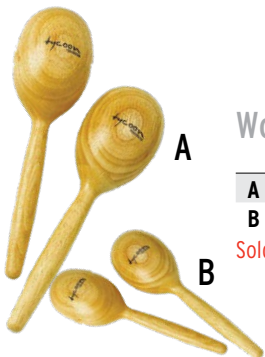

GUIROS

Plastic Guiro

Constructed of specially formulated plastic to enhance durability. Designed to have similar shape, sound, and feel to traditional guiros made from natural gourds. Rubber-lined finger holes allow for added control and playability. Wooden scraper included.



Item#	Retail
TPG-R	\$43.20

Merengue Guiro

Constructed of durable stainless steel. Traditionally designed scraper with ergonomic handle for comfort while playing. Provides the rhythmic foundations of a Merengue band. Scraper included.



Item#	Retail
TPMG	\$167.30

PERCUSSION RACKS

Large Hand Percussion Tray

Large percussion tray with rubber lining which features a fully height adjustable stand, double braced legs and raised sides.



Item#	Retail
TPT-L	\$395.65



REPLACEMENT HEADS

Item#	Description	Retail
TAJ-RH100	African Djembe head 10"	\$38.55
TAJ-RH120	African Djembe head 12"	\$52.35
TJ-RH100	Tunable 10" Goatskin Djembe head	\$38.55
TJ-RH120	Tunable 12" Goatskin Djembe head	\$52.35
TJ-RH130	Tunable 13" Goatskin Djembe head	\$66.10
TB8-RH60	Bongo head 6"	\$24.80
TB8-RH70	Bongo head 7"	\$29.50
TB80-RH85	Bongo head 8.5"	\$38.75

BAGS



Deluxe Padded Bags

- 15mm Padding
- 10mm Sponge
- Heavy duty zippers
- 600D Nylon Outer Shell
- Internal Neck support

Item#	Description	Retail
SGBD-A	Acoustic	\$61.50
SGBD-E	Electric	\$61.50
SGBD-C	Classical	\$61.50
SGBD-B	Bass	\$61.50
SGBD-BAN	Banjo	\$61.50

SAVE = CASE QTY (12)





Padded Guitar Bag

- High density 5mm Padding
- Strong nylon material
- Large front pocket
- Individually boxed

Item#	Description	Retail
SGB-A	Acoustic	\$29.00
SGB-E	Electric	\$29.00
SGB-C	Classical	\$29.00
SGB-B	Bass	\$29.00
SGB-F	Fractional (3/4)	\$29.00
SGB-M	Mandolin	\$22.50

SAVE = CASE QTY (12)



Padded Ukulele Bag

- High density 5mm Padding
- Strong nylon material
- Front pocket

Item#	Description	Retail
SGB-US	Soprano	\$20.50
SGB-UC	Concert	\$22.50
SGB-UB	Baritone	\$25.00
SGB-UT	Tenor	\$23.50

SAVE = CASE QTY (12)

Cajon Bag

- 15mm Padding
- 10mm Sponge
- 600D Nylon Outer Shell
- Heavy duty zipper

Item#	Retail
SGBD-CAJ	\$47.00

SAVE = CASE QTY (12)



Cymbal Bag

- 15mm Padding
- 10mm Sponge
- 600D Nylon Outer Shell
- Heavy duty zipper
- 22" with 15" Hi Hat Compartment

Item#	Retail
SGBD-CYM	\$65.00

SAVE = CASE QTY (12)



MACHINE HEADS



Acoustic Machine Heads

Item#	Description	Retail
A SMH-A33C	3 left heads, 3 right heads, chrome finish	\$25.20
B SMH-A33G	3 left heads, 3 right heads, gold finish	\$40.45
C SMH-A33Cd	3 left heads, 3 right heads, chrome finish, diagonal mount	\$25.20
D SMH-A33Gd	3 left heads, 3 right heads, gold finish, diagonal mount	\$40.45
E SMH-A33Ccd	3 left heads, 3 right heads, chrome finish, covered, diagonal mount	\$16.40



Bass Machine Heads

Item#	Description	Retail
A SMH-B22C	2 left heads, 2 right heads, chrome finish	\$39.05
B SMH-B4C	4 single sided heads, chrome finish	\$39.05
C SMH-B22Co	2 left heads, 2 right heads, open, chrome finish	\$44.60
D SMH-B4Co	4 single sided heads, open, chrome finish	\$44.60



Electric Machine Heads

Item#	Description	Retail
SMH-E6Cd	6 in a line, chrome finish, diagonal mount	\$25.20



Classical Machine Heads

Item#	Description	Retail
A SMH-CN	2 sets of heads, nickel finish	\$14.55
B SMH-CG	2 sets of heads, gold finish	\$22.85



Ukulele Machine Heads

Item#	Description	Retail
A SMH-UN	4 single heads	\$13.65
B SMH-UND	4 single heads, diagonal mount	\$10.85



Mandolin Machine Heads

Item#	Description	Retail
SMH-MN	2 sets of heads, nickel finish	\$25.20

STANDS



Guitar Stand

- Black metal
- Sturdy construction
- Tubular style
- Individually boxed

Item#	Retail
SGS-BLK	\$19.50
SAVE = CASE QTY (12)	



Microphone Stand w/Boom

- Black metal
- Cable clip
- Tripod base
- Sturdy & lightweight
- Individually Boxed

Item#	Retail
SMICS-B-BLK	\$45.00
SAVE = CASE QTY (6)	



Triple Guitar Stand

- Black metal
- Sturdy construction
- Tubular style
- Individually Boxed

Item#	Retail
SGS-3BLK	\$39.00
SAVE = CASE QTY (6)	



Microphone Stand

- Black metal
- Cable clip
- Cast metal base
- Individually Boxed

Item#	Retail
SMICS-BLK	\$47.50
SAVE = CASE QTY (6)	



Foot Stool

- Black metal
- Collapsible
- Fully adjustable
- Sturdy construction
- Individually Boxed

Item#	Retail
SFS-BLK	\$13.50
SAVE = CASE QTY (6)	



Music Stand

- Black metal
- Concert desk style
- Adjustable
- Individually boxed

Item#	Retail
SMS-C-BLK	\$46.50
SAVE = CASE QTY (4)	

HYDRA™ 3 Headed Guitar Stand with 6 Legs

Item#	Retail
H-0600	\$268.80

- 6 legs ensure twice the stability when compared to traditional stands
- Equipped with 3 see-through polycarbonate HEADLOCK™ gates
- Stands strong at a full 30 degrees of tilt
- Works with electric, acoustic, bass, classical, and 12 string guitars

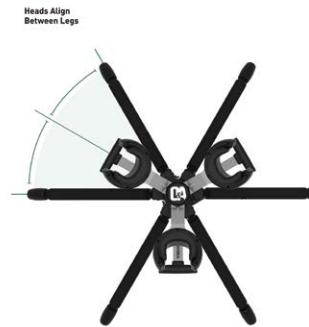

STARFISH™ Grip Guitar Stand with 5 Legs

Item#	Retail
SS-0100	\$89.60

- Quick folding
- 2x as stable
- Grip neck
- Safe for all finishes
- Lifetime guarantee



STARFISH™ + Headlock Guitar Stand with 5 Legs

Item#	Retail
SS-0102	\$125.45

- Quick folding
- 2x as stable
- Locking head
- Safe for all finishes
- Lifetime guarantee



GIGSTAND™ | ICESTAND™ Fold Away Stand

Item#	Description	Retail
GS-0100	Gigstand Electric stand	\$44.80
GS-0200	Gigstand Acoustic stand	\$46.60
GS-0103	Icestand Electric stand	\$44.80
GS-0203	Icestand Acoustic stand	\$46.60



- Collapsible stand
- Portable & Featherweight
- Lattice ribbing and reinforced joints
- Safe for all finishes
- Lifetime guarantee



HEADLOCK™ Wall Hanger with Lock

Item#	Description	Retail
A WH-0200	Black	\$50.20
B WH-0201	Chrome/White	\$53.75

- Self-Closing guitar wall hanger
- Hardware included
- Mounts in minutes
- Safe for all finishes
- Lifetime guarantee

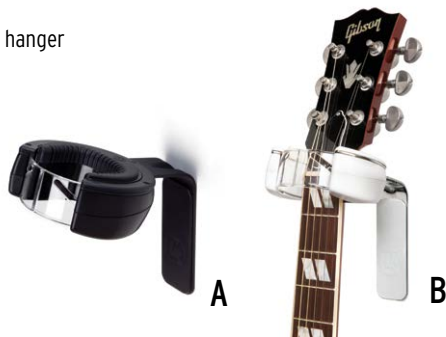

GRIP™ Wall Hanger with Grip

Item#	Description	Retail
A WH-0100	Black	\$26.90
B WH-0101	Chrome/White	\$28.65

- Grip wall hanger
- Hardware included
- Mounts in minutes
- Safe for all finishes
- Lifetime guarantee

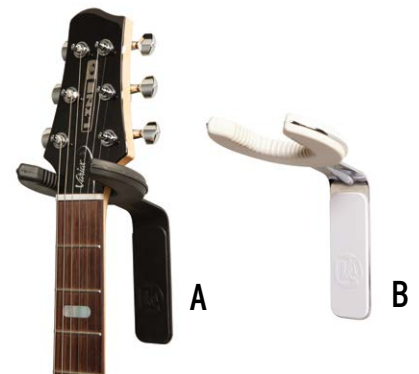

GIG PRESSURE STRAP PAD



*Strap not included



- Relief of pain & aching that can manifest from hours of a heavy instrument resting on a player's shoulder
- It also assists as a preventative to any of those symptoms that many and countless guitarists/bassists face. Enduring 2 years of Research & Development which included dedicated research of the human anatomy and nerve-structure in these problematic areas, makes the D&A Gig Strap a "one of a kind"

Item #	Description	Retail
GST-0100	Gig Pressure Pad Narrow	\$26.90
GST-0200	Gig Pressure Pad Wide	\$26.90

STRUKTURE STANDS

GUITAR STANDS

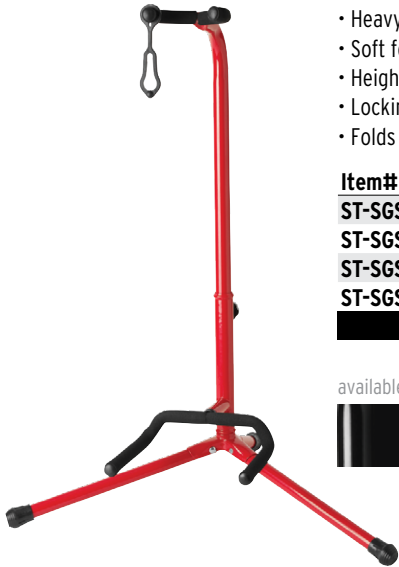

- Heavy duty steel tubing
- Soft foam covered rests
- Height adjustable
- Locking security strap
- Folds for easy storage



Item#	Description	Retail
ST-SGS-BK	Black	\$23.50ea
ST-SGS-RD	Red	\$23.50ea
ST-SGS-WT	White	\$23.50ea
ST-SGS-MIX	3 Black, 2 Red, 1 White	\$23.50ea

SAVE = CASE QTY (12)
Sold in Quantities of 6

available colours



A-Frame Instrument Stand

- Adjustable locking clutch
- Padded arms accommodate
- Rubber back rest & adjustable feet
- High gloss finish



Item#	Description	Retail
A ST-SGA2A-BK	A Frame Acoustic Guitar	\$37.25
B ST-SGA1E-BK	A Frame Electric Guitar	\$37.25

Sold in Quantities of 6
SAVE = CASE QTY (12)

Ukulele / Mandolin Stand

- Black metal
- Sturdy construction
- Tubular style
- Individually boxed

Item#	Retail
ST-SUMS-BK	\$20.00

SAVE = CASE QTY (12)



GUITAR HANGERS

Item#	Description	Retail
A ST-SGH-S1	Metal	\$16.00
B ST-SGH-W2	Wood	\$25.50

Steel Wall Hanger

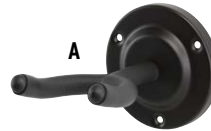

- Designed for both acoustic and electric guitars
- Pivoting yoke cradles most head stocks securely
- Industrial metal base
- Includes mounting hardware

Steel Wall Hanger

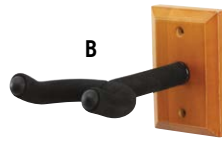

- Designed for both acoustic and electric guitars
- Pivoting yoke cradles most head stocks securely
- Classy hardwood base
- Includes mounting hardware

MICROPHONE STANDS

Stackable Round Base Mic Stand

- Round heavy duty 10 inch base is stackable without disassembly
- Steel shaft adjusts from 35" to 60"
- Standard thread accepts most mic clips/arms
- Includes two clip-on cable restraints

Item#	Description	Retail
ST-SRBM-BK	Black	\$53.50

Sold in Quantities of 6
SAVE = CASE QTY (12)



MUSIC STANDS

Deluxe Folding Music Stand

- Lightweight and strong
- Spring loaded page holders
- Sturdy tripod base
- Includes black carry bag

Item#	Description	Retail
ST-SMSIX-BK	Black	\$21.00
ST-SMSIX-PP	Purple	\$21.00
ST-SMSIX-WT	White	\$21.00
ST-SMSIX-RD	Red	\$21.00
ST-SMSIX-BL	Blue	\$21.00
ST-SMSIX-PK	Pink	\$21.00

SAVE = CASE QTY (12)

available colours



Conductor Style Music Stand

- Sturdy, height adjustable shaft
- Black powder finish
- 12.75" high x 18.5" wide x 1.75" lip
- Adjusts from 24" to 44"

Item#	Description	Retail
ST-SCMS-BK	Black	\$72.75

SAVE = CASE QTY (6)



NEW! TABLET MOUNT

- Works with Apple, Asus, Google, Microsoft, Samsung, and many other manufacturers.
- Mount adjusts from 5.25" to 10".
- Suitable for use with or without a tablet case.
- Allows unrestricted access to tablet controls.
- Easily rotates to any angle.
- Attaches to standard mic thread.
- Includes stand adapter, to attach to stands 1.25" in diameter.

Item#	Retail
ST-SUTM-BK	\$33.50



KEYBOARD STANDS



Item#	Description	Retail
A ST-SK100-KD	Economy Single Brace Black Keyboard Stand	\$43.25
B ST-SK200-KD	Economy Double Brace Black Keyboard Stand	\$65.00

SAVE = CASE QTY (4)

SPEAKER STANDS

- Black metal
- 250lbs capacity
- Industry standard
- Sturdy construction
- Tubular style
- Individually boxed

Item#	Description	Retail
ST-SPRS2	2/pack, black	\$143.25

Sold in quantities of 2 pairs only



FRETTED STAMPS

Item#	Description	Retail
Guitar Fretboard		
MSG-1	5-fret guitar fretboard	\$21.00
MSG-2	13-fret guitar fretboard	\$24.00
MSG-3	5-fret guitar fretboard - half the size of MSG-1	\$21.00
MSG-7	7-string pattern - no nut	\$21.00
MSG-24	24-fret guitar fretboard	\$24.00
MSG-NN	5-fret guitar fretboard - no nut	\$21.00
MSG-3NN	5-fret guitar fretboard - no nut - half the size of MSG-NN	\$21.00
MST-G	6-string pattern	\$28.00
Bass Fretboard		
MST-B	4-string pattern	\$28.00
MSB-1	5-fret bass fretboard	\$21.00
MSB-2	13-fret bass fretboard	\$24.00
MSB-3NN	5-fret bass fretboard - no nut - half the size of MSB-1	\$21.00
Misc. Fretted		
MSBJ-1	Banjo/Ukulele - 4-fret 4-string banjo fretboard	\$21.00
MSBJ-3	Banjo/Ukulele - 4-fret 4-string banjo fretboard half the size of MSBJ-1	\$21.00
MSBJ-5	Banjo/Ukulele - 5-fret 4-string banjo fretboard	\$21.00
MSM-1	Mandolin - 4-fret mandolin fretboard	\$21.00



Say goodbye to those sloppy illegible hand-drawn diagrams.

- Innovative line of self-inking stamps
- Designed and built for music teachers, students, and working musicians
- Helps to clearly illustrate musical notation, theoretical rules, ideas, and concepts quickly and more effectively.

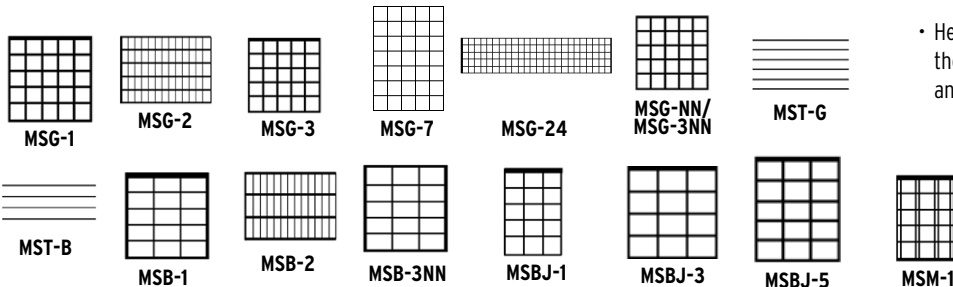

WOODWIND STAMPS

Item#	Description	Retail
MSSB-C	Clarinet - Fingering key diagram	\$24.00
MSSB-S	Saxophone - Fingering key diagram	\$24.00
MSSB-O	Oboe - Fingering key diagram	\$24.00
MSSB-B	Bassoon - Fingering key diagram	\$28.00

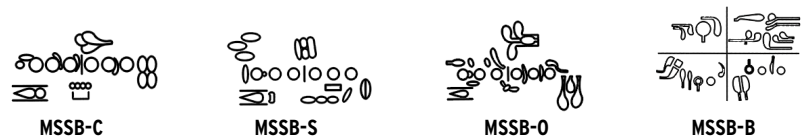

MISCELLANEOUS STAMPS

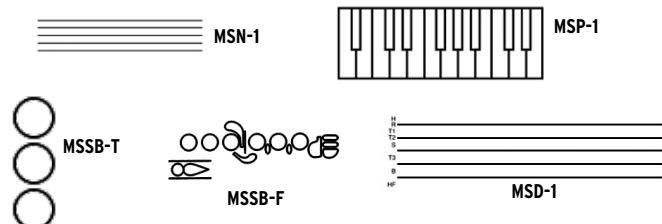

Item#	Description	Retail
MSN-1	Standard Notation - 5-line staff	\$26.00
MSP-1	Piano - 1-octave piano keyboard	\$24.00
MSSB-T	Trumpet - For 3-valve instruments	\$21.00
MSSB-F	Flute - Fingering key diagram	\$26.00
MSD-1	Drum Stamp	\$28.00

STANDARD PICKS



Control

Nylon

A rhythm and lead pick in one. All-around ability and excellent sound quality.

Item#	Description	Retail
D0508	5 pcs / bag	\$4.50
D7368	36 pcs / bag	\$31.75



Control

Poly Gels

Made from polycarbonate material, these gels give you all the features of Dava's original Control Pick. Great durability, and come in vivid translucent colours.

Item#	Description	Retail
D8508	5 pcs / bag	\$4.50
D8368	36 pcs / bag	\$31.75



Rock Control

Delrin

Molded Delrin tip with increased 'Control Area' for extended playing life. A smooth, fast release & dynamic harmonic response.

Item#	Description	Retail
D1303	6 pcs / bag	\$9.00
D1336	36 pcs / bag	\$53.00



Rock Control

Nickel Silver

Flexi-Steel tip has incredible sound clarity and tone, the multi-gauge design can go from soft strumming to heavy lead.

Item#	Description	Retail
D0109	1 pc / bag	\$3.50



Grip Tips

Delrin

Unique molded rubber grip for additional playing feel and long lasting positive action tip. Assorted colours.

Item#	Description	Retail
D6024	6 pcs / bag	\$9.00
D6036	36 pcs / bag	\$53.00



Grip Tips

Nylon

Patented over-molding technology and multi-gauge flexibility, these picks feature a velvety rubber feel and unparalleled grip.

Item#	Description	Retail
D6924	6 pcs / bag	\$9.00
D6936	36 pcs / bag	\$53.00



Grip Tips

Poly Gels

Made from a popular polycarbonate material, these gels give you all the features of Dava's original control pick designs, and have great durability.

Item#	Description	Retail
D6624	6 pcs / bag	\$9.00
D6636	36 pcs / bag	\$53.00



NEW! Grip Tips

Power Grip

Heavy duty 1.5mm grip pick. a heavy rock pick with no flexibility and with a superior grip.

Item#	Description	Retail
D2024	6 pcs / bag	\$9.00
D2036	36 pcs / bag	\$53.00

JAZZ SHAPE PICKS



Jazz Grips

Delrin

Smaller size for better grip, with a sharp tip that allows for precision.

Item#	Description	Retail
D9024	6 pcs / bag	\$9.00
D9036	36 pcs / bag	\$53.00



Jazz Grips

Nylon

Smaller size for better grip, with a sharp tip that allows for precision.

Item#	Description	Retail
D9124	6 pcs / bag	\$9.00
D9136	36 pcs / bag	\$53.00



Jazz Grips

Poly Gels

Smaller size for better grip, with a sharp tip that allows for precision.

Item#	Description	Retail
D9224	6 pcs / bag	\$9.00
D9236	36 pcs / bag	\$53.00



OTHER OPTIONS

Try It Pack

Combo 5 Pack

Control (Nylon), Rock Control (Delrin), Master Control (Nickel), Grip Tips (Delrin), Jazz Grip (Delrin)

Item#	Retail
D8125	\$8.80

KAZOOBIE KAZOOS

KAZOOS

Classic American Kazoo

- USA made
- 30+ colour combinations
- Very hygienic, individually wrapped
- Individual barcodes
- Child safety tested
- Bilingual packaging

Item#	Retail
SKAZ-P1	\$2.10 ea
SKAZ-PIUB	\$113.75

QUANTITY DISCOUNTS AVAILABLE



Wazoo

- USA made
- Loudest acoustic kazoo
- Unique item
- Bagged with barcode

Item#	Retail
SKAZ-PIWAZ	\$7.85



Kazobo

- USA made
- Largest and loudest kazoo
- Vibrant Colours
- Dual resonators that enhance vibration

Item#	Retail
SKAZ-OBO	\$25.30



Lanyard Kazoo

- USA made
- Individually Polybagged
- Vibrant Colours
- Never Lose Your Kazoo Again

Item#	Retail
SKAZ-P1LAN	\$5.25



Electric Kazoo

- USA made
- 1/4" plug, 15' cable
- Dynamic microphone
- Professional quality

Item#	Retail
SKAZ-PIE	\$45.85



D'Addario

1 - 170 ALDEN RD
MARKHAM ON, L3R 4C1
1.800.268.6855

DADDARIOCANADA.COM

DDCO118EX



0 19954 26836 7