

KURZWEIL

M210
USER'S
MANUAL

English Manual

HDC YOUNG CHANG
MUSIC

KURZWEIL

IMPORTANT SAFETY INSTRUCTIONS

1. Read these instructions.
2. Keep these instructions.
3. Heed all warnings.
4. Follow all instructions.
5. Do not use this apparatus near water.
6. Clean only with dry cloth.
7. Do not block any of the ventilation openings. Install in accordance with the manufacturer's instructions.
8. Do not install near any heat sources such as radiators, heat registers, stoves, or other apparatus (including amplifiers) that produce heat.
9. Do not defeat the safety purpose of the polarized or grounding-type plug. A polarized plug has two blades with one wider than the other. A grounding type plug has two blades and a third grounding prong. The wide blade or the third prong are provided for your safety. If the provided plug does not fit into your outlet, consult an electrician for replacement of the obsolete outlet.
10. Protect the power cord from being walked on or pinched, particularly at plugs, convenience receptacles, and the point where they exit from the apparatus.



11. Only use attachments / accessories specified by the manufacturer.
12. Use only with a cart, stand, tripod, bracket, or table specified by the manufacturer, or sold with the apparatus. When a cart is used, use caution when moving the cart / apparatus combination to avoid injury from tip-over.
13. Unplug this apparatus during lightning storms or when unused for long periods of time.
14. Refer all servicing to qualified service personnel. Servicing is required when the apparatus has been damaged in any way, such as power-supply cord or plug is damaged, liquid has been spilled or objects have fallen into the apparatus, the apparatus has been exposed to rain or moisture, does not operate normally, or has been dropped.
15. Allow adequate ventilation for the power adapter. Do not hide it under a carpet or behind a curtain or place it in an enclosed space where heat buildup can occur.

WARNING: To reduce the risk of fire or electric shock, do not expose this apparatus to rain or moisture. Do not expose this equipment to dripping or splashing and ensure that no objects filled with liquids, such as vases, are placed on the equipment.

To completely disconnect this equipment from the AC Mains, disconnect the power supply cord plug from the AC receptacle.

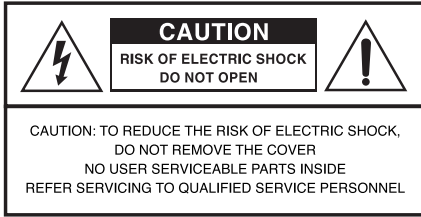

The lightning flash with the arrowhead symbol, within an equilateral triangle, is intended to alert the user to the presence of uninsulated (dangerous voltage) within the product's enclosure that may be of sufficient magnitude to constitute a risk of electric shock to persons.



The exclamation point within an equilateral triangle is intended to alert the user to the presence of important operating and maintenance (servicing) instructions in the literature accompanying the product.

IMPORTANT SAFETY & INSTALLATION INSTRUCTIONS

INSTRUCTIONS PERTAINING TO THE RISK OF FIRE, ELECTRIC SHOCK, OR INJURY TO PERSONS

WARNING : When using electric products, basic precautions should always be followed, including the following:

1. Read all of the Safety and Installation Instructions and Explanation of Graphic Symbols before using the product.
2. Do not use this product near water—for example, near a bathtub, washbowl, kitchen sink, in a wet basement, or near a swimming pool, or the like.
3. This product should only be used with a stand or cart that is recommended by the manufacturer.
4. This product, either alone or in combination with an amplifier and speakers or headphones, may be capable of producing sound levels that could cause permanent hearing loss. Do not operate for a long period of time at a high volume level or at a level that is uncomfortable. If you experience any hearing loss or ringing in the ears, you should consult an audiologist.
5. The product should be located so that its location or position does not interfere with its proper ventilation.
6. This product should be located away from heat sources such as radiators, heat registers, or other products that produce heat.
7. This product should be connected to a power supply only of the type described in the operating instructions or as marked on the product.
8. This product may be equipped with a polarized line plug (one blade wider than the other). This is a safety feature. If you are unable to insert the plug into the outlet, contact an electrician to replace your obsolete outlet. Do not defeat the safety purpose of the plug.
9. The power supply cord of the product should be unplugged from the outlet when left unused for a long period of time. When unplugging the power supply cord, do not pull on the cord, but grasp it by the plug.
10. Care should be taken so that objects do not fall and liquids are not spilled into the enclosure through openings.
11. The product should be serviced by qualified service personnel when:
 - A. The power supply cord or the plug has been damaged;
 - B. Objects have fallen, or liquid has been spilled into the product;
 - C. The product has been exposed to rain;
 - D. The product does not appear to be operating normally or exhibits a marked change in performance;
 - E. The product has been dropped, or the enclosure damaged.
12. Do not attempt to service the product beyond that described in the user maintenance instructions. All other servicing should be referred to qualified service personnel.
13. **WARNING :** Do not place objects on the product's power supply cord, or place the product in a position where anyone could trip over, walk on, or roll anything over cords of any type. Do not allow the product to rest on or be installed over cords of any type. Improper installations of this type create the possibility of a fire hazard and/or personal injury.

RADIO AND TELEVISION INTERFERENCE

WARNING : Changes or modifications to this instrument not expressly approved by KURZWEIL could void your authority to operate the instrument.

IMPORTANT : When connecting this product to accessories and/or other equipment use only high quality shielded cables.

NOTE : This instrument has been tested and found to comply with the limits for a Class B digital device, pursuant to Part 15 of the FCC Rules. These limits are designed to provide reasonable protection against harmful interference in a residential installation. This instrument generates, uses, and can radiate radio frequency energy and, if not installed and used in accordance with the instructions, may cause harmful interference to radio communications. However, there is no guarantee that interference will not occur in a particular installation. If this instrument does cause harmful interference to radio or television reception, which can be determined by turning the instrument off and on, the user is encouraged to try to correct the interference by one or more of the following measures:

The normal function of product may be disturbed by strong electro magnetic

interference. If so, simply reset the product to resume normal operation by following the instruction manual.

In case the function could not resume, please use the product in other location.

- Reorient or relocate the receiving antenna.
- Increase the separation between the instrument and the receiver.
- Connect the instrument into an outlet on a circuit other than the one to which the receiver is connected.
- If necessary consult your dealer or an experienced radio/television technician for additional suggestions.

NOTICE : This apparatus does not exceed the Class B limits for radio noise emissions from digital apparatus set out in the Radio Interference Regulations of the Canadian Department of Communications.

AVIS : Le présent appareil numérique n'émet pas de bruits radioélectriques dépassant les limites applicables aux appareils numériques de la class B prescrites dans le Règlement sur le brouillage radioélectrique édicté par le ministère des Communications du Canada.

SAVE THESE INSTRUCTIONS

Contents Table of Contents

Chapter 1	Front Panel	6	Chapter 8	Metronome/Rhythm	20
	Main Buttons	6		Selecting a Style	20
Chapter 2	Main Features	7	Chapter 9	Record/X-Pose	21
	Main Features	7		Recording a Performance	21
Chapter 3	Piano Assembly	8	Chapter 10	Demo Songs	22
	1. Piano Assembly	8		Listening to Demo Songs	22
	2. Applying Power	11	Chapter 11	Pedals	23
	3. Setting the Volume	11		1. Pedals	23
Chapter 4	Selecting Sounds	12		2. Using the Pedals	23
	1. Selecting Sounds	12	Chapter 12	MIDI	24
	2. List of Voices	13		1. MIDI Channel	24
	3. List of Rhythms	13		2. Connecting to a Computer	24
Chapter 5	Layering	14	Chapter 13	Connection	26
	Layering Two Sounds	14		1. Using Headphones	26
Chapter 6	Splitting	15		2. Aux In	26
	1. Splitting the Keyboard	15		3. Aux Out	26
	2. Dual(Duo) mode	16		4. MP3 Aux In	26
Chapter 7	Functions	17	Chapter 14	Demo Song List	27
	1. Function Mode	17	Chapter 15	Drum Sets	28
	2. Selecting a Function	17	Chapter 16	Specifications	30

Main Buttons

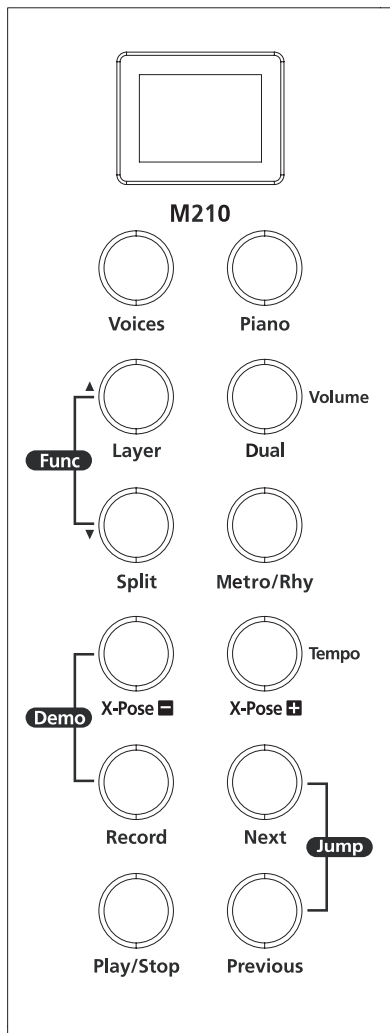
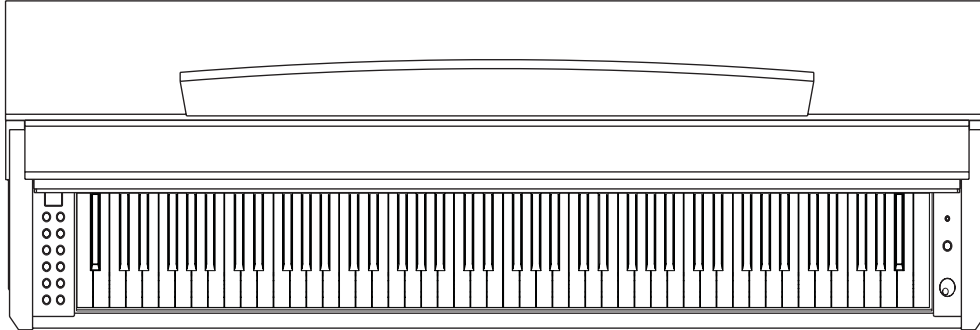

- (1) **Voices button**
Select among the 20 voices with the [Voices] button.
- (2) **Piano button**
Always selects "Grand Piano" sound.
- (3) **Dual button (Duo mode)**
This function allows two different players to play.
- (4) **Metro/Rhy button**
Select among the 12 rhythms or metronome beat.
- (5) **Layer button**
You can layer two voices and play them simultaneously to create a thicker and richer sound.
- (6) **Split button**
For playing different voices on the left-hand and right-hand section of the keyboard.
- (7) **Demo button pair**
Press together to select among the 50 demonstration songs.
- (8) **Func button pair**
Press together to set functions like Tune, Touch, Effect, etc.
- (9) **Record button**
For recording your keyboard performance.
- (10) **Play/Stop button**
These control playback of or stop the demonstration songs and your recorded song.
- (11) **Next button**
Select the next higher Voice, Rhythm, or Demo Song, etc.
- (12) **Previous button**
Select the next lower Voice, Rhythm, or Demo Song, etc.

Thank you for purchasing a KURZWEIL Digital Piano. We recommend that you read this manual carefully so that you can fully take advantage of the advanced and convenient functions of your KURZWEIL Digital Piano.

Main Features

- 88 Dynamic Touch Graded Hammer action keys with the feel of real Grand Piano
- 3 Pedals (Sustain, Sostenuto, Soft)
- 4 Touch sensitivity settings
- Stereo audio Input, Output
- 2 Headphone jacks
- USB MIDI
- 7 Segment LED display
- 20 Voices
- 12 Rhythms with accompaniment
- Transpose, Tune functions
- Layer, Split, Dual(Duo) mode
- Recording function
- MP3 Aux In

Chapter 3 Piano Assembly

Check that all of the following items are present.

Part Name	Q'ty	Part Name	Q'ty
① Keyboard	1 EA	⑥ Screws for side panel and keyboard (25mm)	4 EA
② Side panel of stand (Left)	1 EA	⑦ Screws for side panel and pedal box (25mm)	4 EA
③ Side panel of stand (Right)	1 EA	⑧ Screws for side panel and rear panel	4 EA
④ Pedal box	1 EA	⑨ Screws for rear panel	4 EA
⑤ Rear panel	1 EA	⑩ Cord holder	2 EA

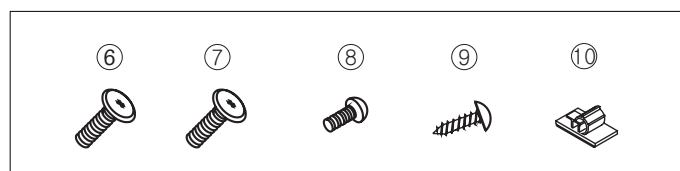
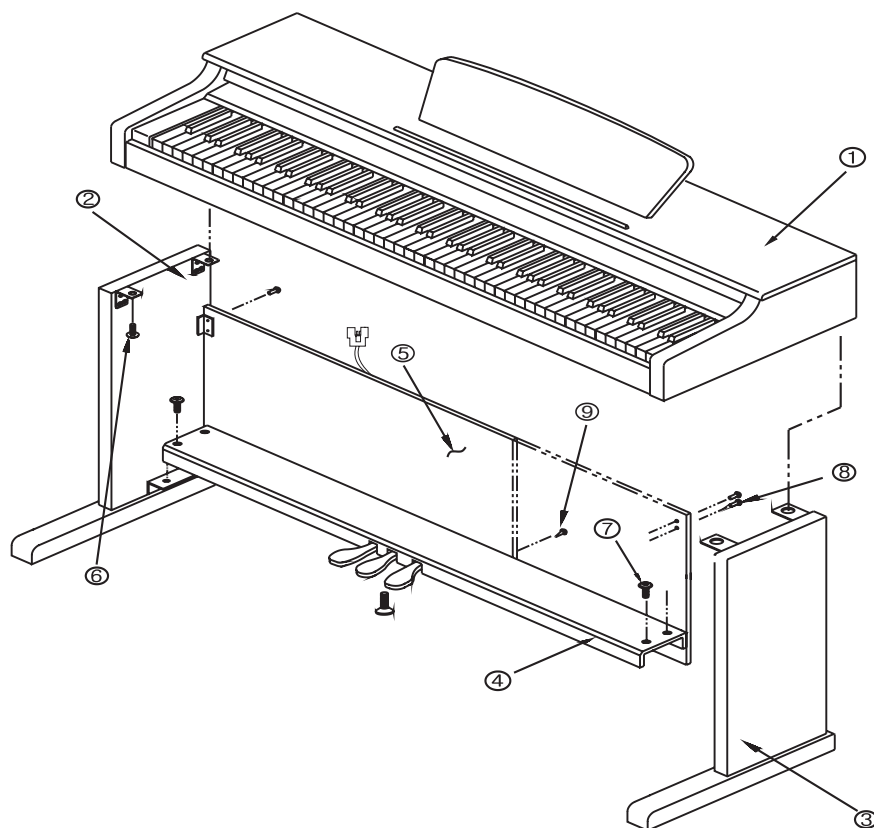

Please check the quantity of related part.

1. Stand Assembly



- Assembly should be carried out by at least two persons.
- Assemble the stand on a hard and flat floor with ample space.
- Be sure to use the included screws, and insert screws of the correct size in the correct hole locations. Use of incorrect screws can damage the product.

1) Side Panel and Pedal Box assembly

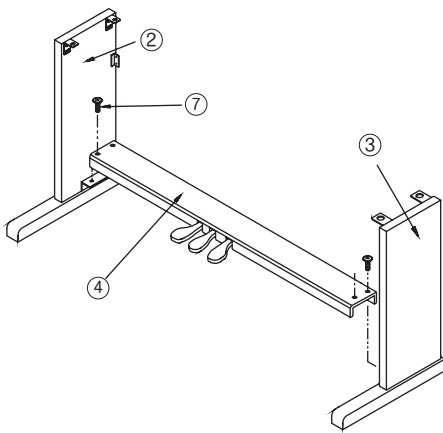

1. Place the pedal box ④ on the left side panel ② and use ⑦ screws to fasten the side panel.
2. Place the pedal box ④ on the right side panel ③ and use ⑦ screws to fasten the side panel.
3. You can find the pedal cable in the pedal box ④. Untie and straighten out the bundled pedal cable.

2) Rear Panel assembly

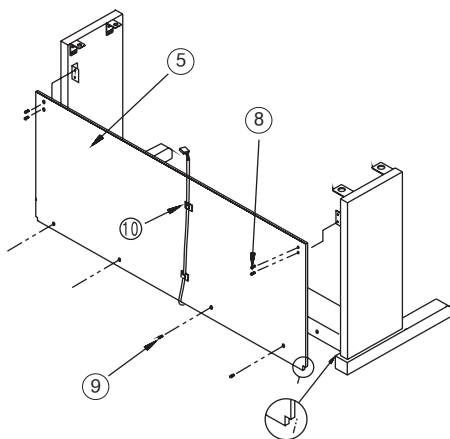

1. Fit into the rear panel's hole in the side panel brackets and then use the screws ⑧ to fasten the rear panel.
2. Use the screws ⑨ to fasten the bottom of the rear panel.

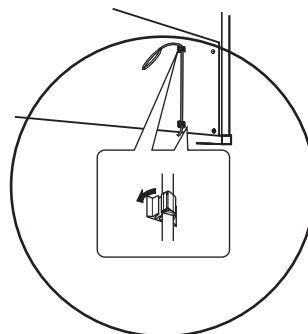

Attach the pedal cord holders to the rear panel as shown, then clip the cord into the holders

3) Mounting the keyboard

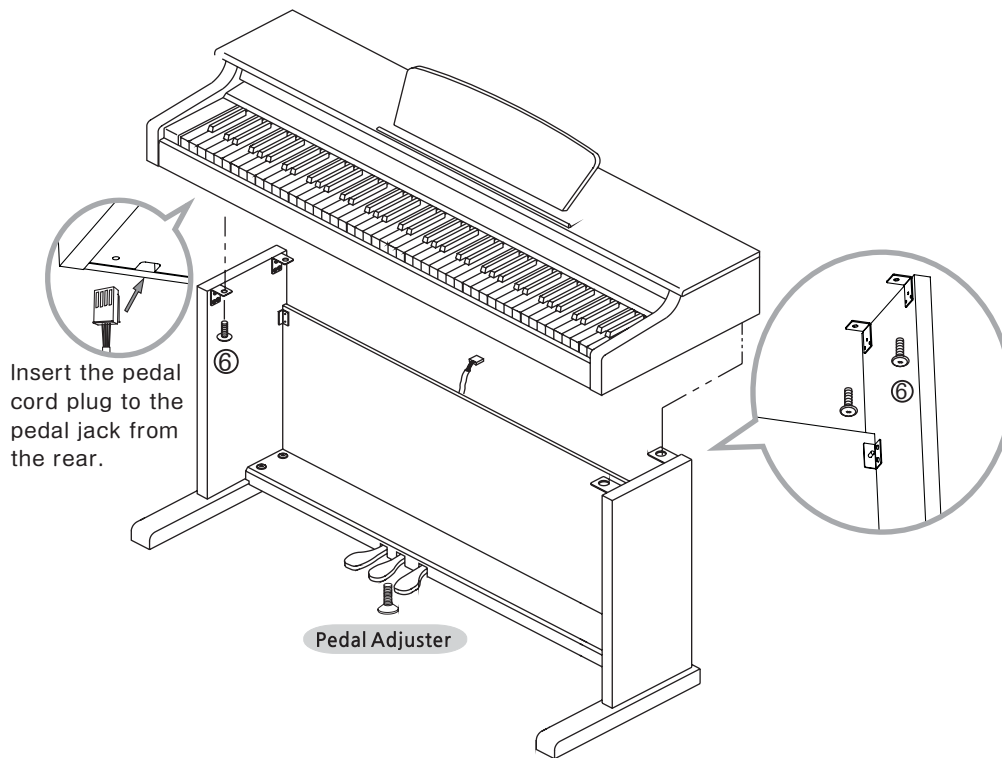

1. Place the keyboard on the stand and fit into the holes in the side panel brackets.
2. Fasten the keyboard to the side panel using screws ⑥.

CAUTION : Have a second person hold the keyboard steady until the side panel screws are installed.

3. Insert the pedal cable plug into the pedal jack located on the bottom of the keyboard.

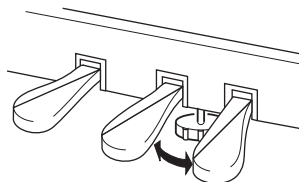

4. Rotate the pedal adjuster until it comes in firm contact with the floor surface.
If the adjuster is not in firm contact with the floor, the pedals will wobble and may malfunction.

2. Applying Power

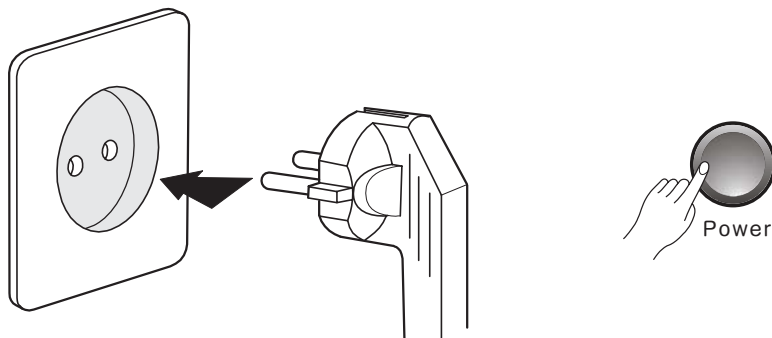

1) Connecting the power cord

First insert the plug of the AC power cord into the AC connector on the Adaptor, then plug the other end of the cord into the proper AC outlet on the wall. In some areas a plug adaptor may be provided to match the pin configuration of the AC wall outlets in your area.

2) Plug the thin DC power cord into the DC Power Jack on the back of the piano.

3) Turn the power on

Press the power switch located on the right of the front panel to turn the power on. The display located in the center of the front panel should light with various patterns and after a short time display "U11"(OS Version) and "n01"(Grand Piano).

CAUTION

Even when the instrument is turned off, AC power is still flowing to the adapter at a minimum level. When you are not using the instrument for a long time or during electrical storms, unplug the AC power cord from the wall outlet.

3. Setting the Volume

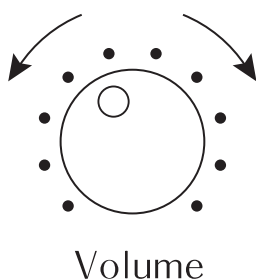

To adjust the volume, use the [Volume] knob located at the right of front panel. Play the keyboard while you adjust the knob to a comfortable and realistic volume.

NOTE

Adjusting the [Volume] knob also affects the output level of the Phones jacks and the output level of the Audio Out jacks.

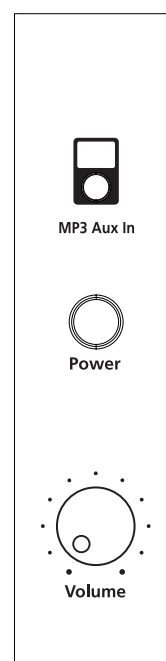

1. Selecting Sounds

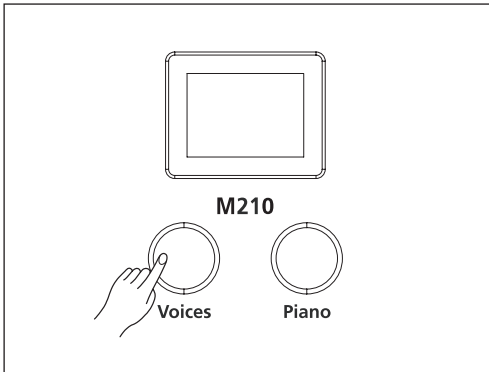

There are two ways of selecting one of the 20 voices : with the [Voices] button and the [Piano] button.

Press the [Voices] button. Then use the [Next] or [Previous] button to select different voices in sequence.

Please refer to the table on the next page which contains the list of all available voices and their assigned keys.

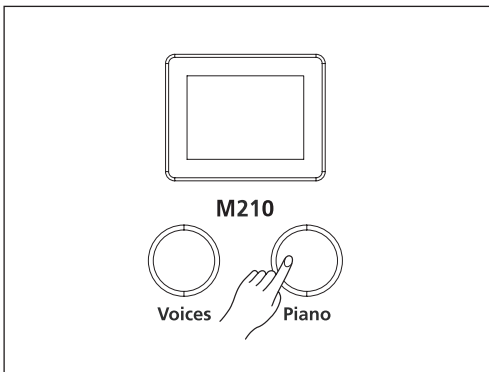

If you want to play the Grand Piano voice immediately, press the [Piano] button to set current voice to "n01, Grand Piano".



"n" means that Main(primary) sound.
"01" means that voice number (page 13).

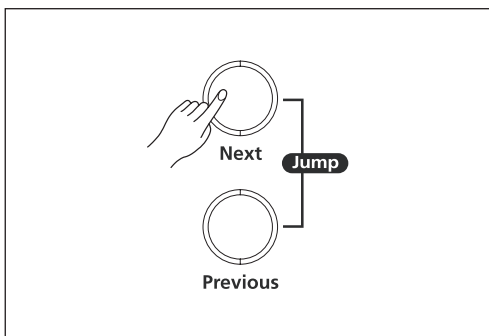

If you press and hold the [Next] or [Previous] buttons, the voice numbers will begin to change quickly.

If you press the [Next] and [Previous] buttons together, it will skip to the first voice in the next category of voices.

2. List of Voices

No.	Voice
1	Grand Piano
2	Bright Piano
3	Elec Piano 1
4	Elec Paino 2
5	Harpsichord
6	Vibraphone
7	Organ 1
8	Organ 2
9	Steel Guitar
10	Jazz Guitar
11	Acoustic Bass
12	Slap Bass
13	Violin
14	Cello
15	Strings
16	Choir
17	Trumpet
18	Brass
19	Flute
20	Drum Sets

3. List of Rhythms

No.	Rhythm
1	Fast Funky
2	Break Beat
3	80's Pop
4	Funky Pop
5	Techno
6	Soul Beat
7	Slow Rock
8	Country Rock
9	Pop Disco
10	Big Band
11	Waltz
12	Polka

Layering Two Sounds

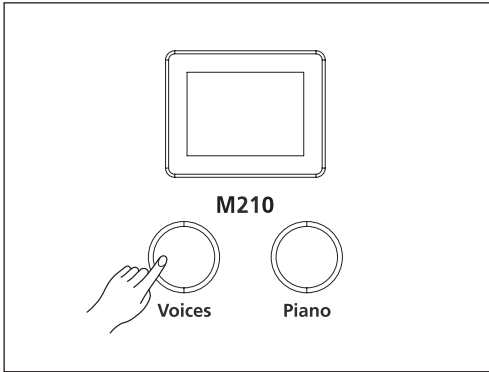

This function lets you layer and play two different sounds at the same time. You can layer voices of two different voices in the same category, and create a composite voice of greater richness and texture.

Select the main voice in the usual way with the [Voices], the [Next] or the [Previous] button if needed.

The primary(main) voice is "Grand Piano" by default.

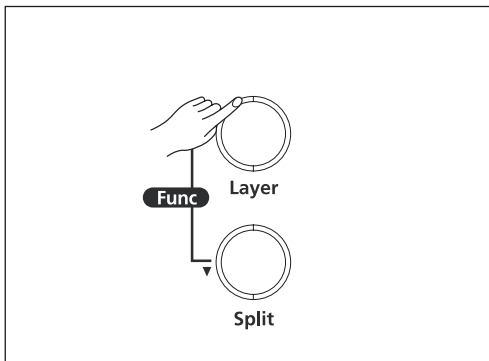

Then press the [Layer] button and use the [Next] or the [Previous] button to select a voice to be layered with the first one.

The secondary(layered) voice is "Strings" by default.



"L" means that Layer(secondary) sound.
 "15" means that voice number (page 13).

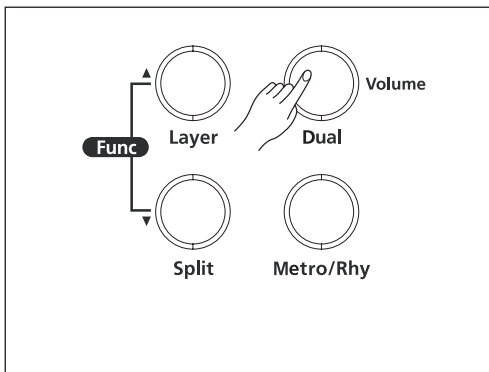

Setting the Layer Volume

If you want, use the [Volume] button to adjust the volume balance between two voices in layer mode.

It can be set to any number between 0 and 127. By default, the Layer Volume is setting to 70, which results in the secondary sound being a little softer than the primary(main) sound.

Note :

You can not change the primary sound volume. It is always setting to max 127.

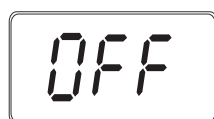

Pedal Setting

The sustain pedal can be enabled or disabled while you are in layer or split mode. While holding down the [Layer] button or [Split] button, press the sustain pedal.

1. Splitting the Keyboard

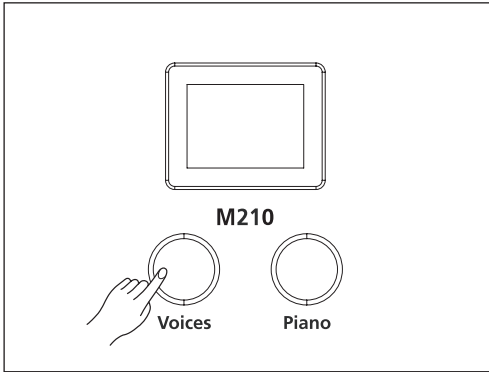

Split mode enables you to play two different voices on the keyboard – one with the left hand and another with the right hand. For example, you can play a bass part using the Bass voice with the left hand and a melody voice with the right hand.

Select the primary voice in the usual way with the [Voices], the [Next] or the [Previous] button if needed.

The primary(right hand) voice is "Grand Piano" by default.

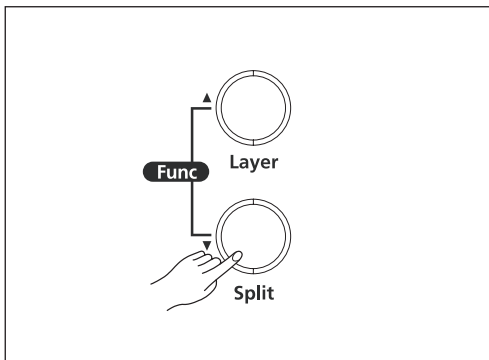

Then press the [Split] button and use the [Next] or the [Previous] button to select a split voice.

The secondary(left hand) voice is "Acoustic Bass" by default.

Note :

It is transposed one octave up automatically.



"P" means that sPlit(secondary) sound.
 "11" means that voice number (page 13).

Setting the Split Point

By default the split point is just below "F 3". To change the split point, use the [Split] button.

While the keyboard is split, hold down the [Split] button about 3 second and the LED will display "F 3" which is the default.

To change, press a key on the keyboard until the LED shows the desired split point.

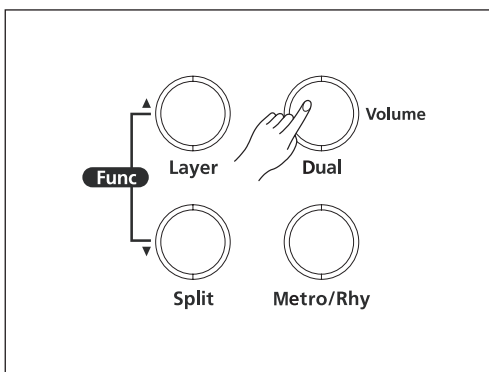

Setting the Split Volume

If you want, use the [Volume] button to adjust the volume balance between two voices in split mode.

It can be set to any number between 0 and 127. By default, the Split Volume is setting to 100, which results in the secondary sound being a little softer than the primary(main) sound.

Note :

You can not change the primary sound volume. It is always set to max 127.

2. Dual(Duo) mode

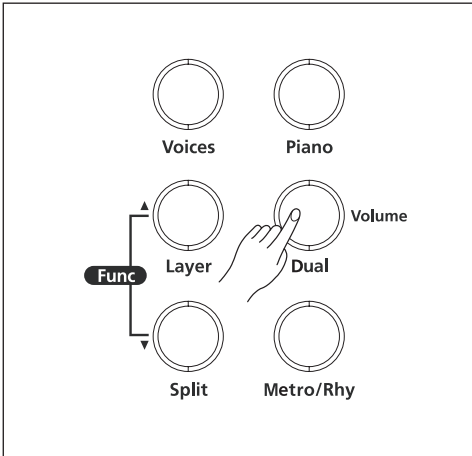

The Dual(Duo) mode allows two different players to play the instrument, one on the left and one in the right, over the same octave range.

The keyboard is divided into two sections with the E3 key as Split Point.

Note 1 :

The Split Point cannot be changed from E3.

Note 2 :

Since Dual(Duo) is designed for two player piano performance, different voice cannot be assigned to Left and Right voice.

Pedal function in Dual(Duo)

- 1) Sustain pedal : Applies sustain to the right section.
- 2) Sostenuto pedal : Applies sostenuto to both sections.
- 3) Soft pedal : Applies sustain to the left section.

1. Function Mode

- 1) Style Volume
- 2) Accompaniment
- 3) Reverb
- 4) Chorus
- 5) Effect Level
- 6) Tune
- 7) Touch Sensitivity
- 8) Demo Loop
- 9) Temperaments
- 10) Local Control

2. Selecting a Function

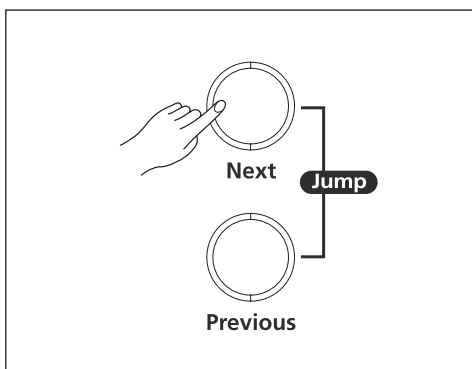
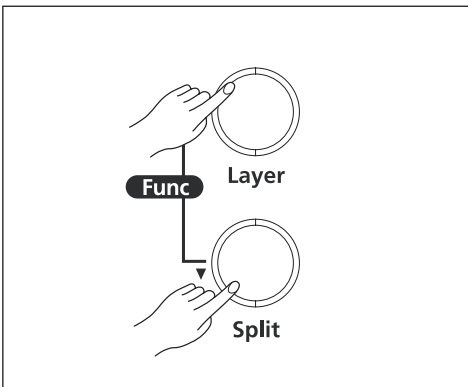

To go to Function Mode, press the [Func] button pair (press [Layer] and [Split] button together). The LED will show "55" which indicates the style volume setting. The number displayed is the current setting of the parameter. To change the parameter setting, use the [Next] button and the [Previous] button. Press the [Layer] or [Split] button to move to the next or the previous parameter. When you want to quit Function Mode, press the [Voices] or [Piano] button.

1) Style Volume

You can adjust the volume level of the style.
The range is between 1 to 100 and the default setting is 55.

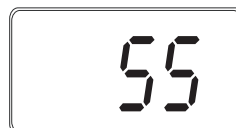

2) Accompaniment

You can change the Accompaniment mode of the style. If you select "Aon", you can hear the Drum, Bass and Accompaniment of the style. If you select "AoF", you can only hear the Drum pattern sound.



3) Reverb

The appropriate Reverb type and Level(depth) are called up automatically when you select each of the voices. This is why the Reverb need not be selected, however, you can select a reverb type. Available reverbs are Off, Room, Hall 1, Hall 2, Stage.

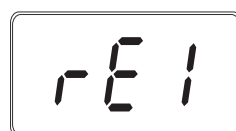

1. rE0 : Off
2. rE1 : Room
3. rE2 : Hall 1
4. rE3 : Hall 2
5. rE4 : Stage

4) Chorus

You can select a chorus type. Available chorus types are Off, Chorus, Phaser, Tremolo.



1. cH0 : Off
2. cH1 : Chorus
3. cH2 : Phaser
4. cH3 : Tremolo

5) Effect Level

You can adjust the intensity of the reverberation or other effect used by each voice. Normal is 60 but that can be adjusted by using the [Next] and [Previous] buttons. The range is from 0(no effect) to 127(max).



6) Fine Tuning

You can finely tune the pitch up or down in about 0.5Hz steps. This function is useful when you play or record with another instrument that is slightly out of tune or can't be easily retuned. The default setting is "40.0" (440Hz). The range is -427.0Hz to 453.0Hz. The LED will display from 27.0 to 53.0, but not displayed the dot. The [Jump] button pair will restore the default setting.



7) Touch Sensitivity

You can adjust how the keyboard responds to your playing. Available touch sensitivity is Flat, Hard, Normal, Soft. The default setting is Soft.



1. to1 : Flat
2. to2 : Hard
3. to3 : Normal
4. to4 : Soft

8) Demo Loop

You can set a playback mode for demo repeat. The default setting is "All"

- 1) Off : Demo songs only play once.
- 2) One : Repeat playing of one song.
- 3) All : Repeat playing of all songs.

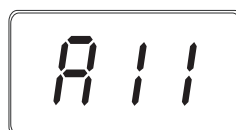

9) Temperaments

Various historical temperaments other than the modern "Equal" can be selected. Available temperaments are Equal, Pythagorean, Pure Major, Pure Minor, Mean Tone, Werckmeister III, Kirnberger III.

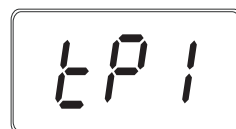

1. Equal
2. Pythagorean
3. Pure Major
4. Pure Minor
5. Mean Tone
6. Werckmeister III
7. Kirnberger III

10) Local Control

You can set Local Control on or off here. Local Control is the connection between keyboard and internal sound producing circuitry (engine). When Local Control is set to "On", the keyboard delivers your performance information to the sound engine, so you can hear the sounds you play. At the same time, the instrument transmits MIDI information via its USB port.



There are, however, cases you need to set Local Control to "Off". When using the instrument with an external MIDI sequencer or computer via MIDI, the instrument may play the same note twice—once by the direct sound engine connection and once by the "echo" through the sequencer and coming back. You can eliminate the echoing of notes by setting Local Control to "Off" which interrupts the direct connection. The default setting is "On".

Chapter8 Metronome/Rhythm

This instrument features a variety of rhythmic backing patterns with accompaniment (called "**Style**") in a variety of different musical genres including pop, waltz and many others.

Selecting a Style

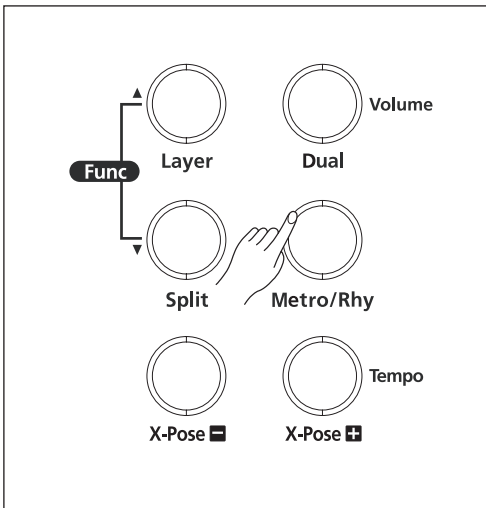

Playing a Style :

- 1) Pressing the [Metro/Rhy] button will start the style playback when a style is selected. Pressing the same button again will stop the style playback.
- 2) To select a style, hold the [Metro/Rhy] button down. The LED will show the currently selected style number.
- 3) Choose different preset styles with the [Next] and [Previous] buttons. (Refer to the rhythm list on page 13)

Tempo :

Change the style tempo by pressing the [Tempo] button. The [Next] and [Previous] buttons will speed up or slow down the tempo. The range is 30 to 250.

Volume :

Use the [Volume] button then the [Previous] and [Next] buttons to adjust the volume level of the style. The range is from 1 to 100 and the default setting is 55.

Playing a Metronome :

- 1) Pressing the [Metro/Rhy] button will start the metronome when a metronome signature is selected. Pressing the same button again will stop the metronome.
- 2) To select a metronome signature, hold the [Metro/Rhy] button down. The LED will show the currently selected metronome signature.
- 3) Choose different metronome signatures with the [Next] and [Previous] buttons.
- 4) Available signatures are 1/4, 2/4, 3/4, 4/4, 6/4, 6/8.

Chapter 9 Record/X-Pose

You can record and playback your performance much like a tape recorder. This function can greatly enhance your composition and performance results.

Recording a Performance

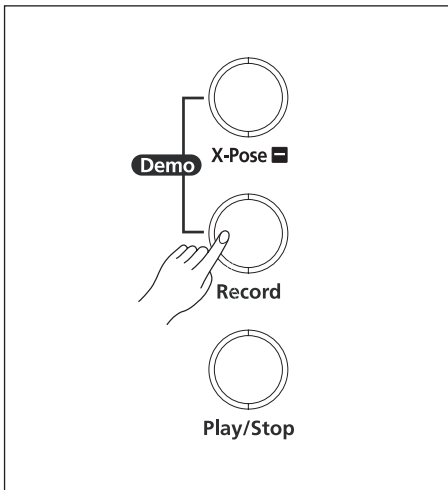

- 1) Press the [Record] button. A metronome count down of one measure will be heard before recording begins.
- 2) Then press the [Play/Stop] button.
- 3) Alternatively, play a key on the keyboard directly, and the recording will begin immediately.
- 4) Play your performance, then press the [Play/Stop] again or the [Record] button to stop recording.
- 5) Press the [Play/Stop] button to start playback.
- 6) You can easily replace all of a saved user song by recording again.
- 7) To delete recorded songs, hold down the [Record] button about 3 seconds. Then the LED will show "dEL".

X-Pose(Transpose)

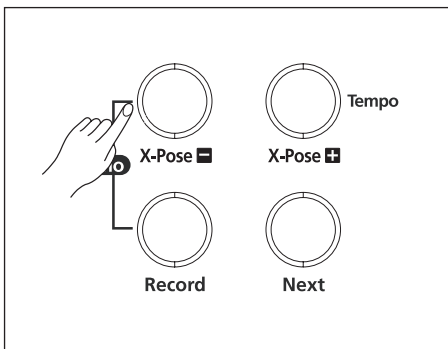

You can shift the pitch of the entire keyboard up or down in order to facilitate playing in difficult key signatures to easily match of the keyboard to a singer. The range is between -24 to 24 semitones.

The [X-Pose -] LED lights while the X-Pose value is minus, otherwise, the [X-Pose +] LED lights while its value is plus. The default setting is 0 and no light.

Note :

You can't hear any sound when you hit the lowest or highest keys while it transposed up or down to +/- 20.

Listening to Demo Songs

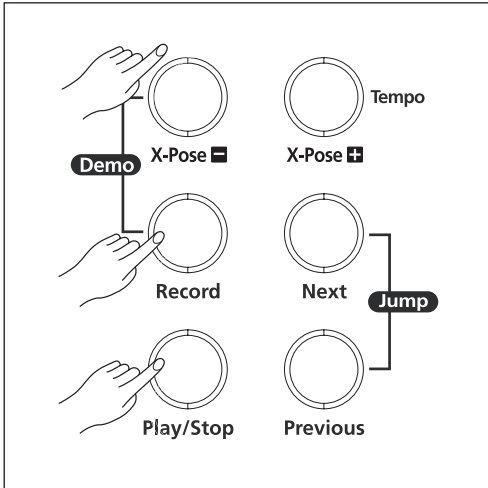

- 1) Press the [Demo] button pair to enter the demo mode. (Press the [Record] and [X-Pose] buttons at the same time to access the demo songs)
- 2) To select a demo song, press the [Next] or [Previous] button. (Refer to the demo songs list on page 27)
- 3) Alternatively, you can select a song by pressing a key on the keyboard.
- 4) Press the [Play/Stop] button to start playback.
- 5) Press the [Play/Stop] button again to stop playback.
- 6) To exit the demo mode, press the [Demo] button. (Press the [Record] or [X-Pose] button).

You can set a playback mode such as Off, One or All for demo repeat in Function mode (page 19).

- 1) Off : Demo songs only play once.
- 2) One : Repeat playing of one song.
- 3) All : Repeat playing of all songs.

The LED will show the number of the demo song currently playing.



1. Pedals

This piano has three foot pedals : damper(sustain) pedal (right), sostenuto pedal (center) and soft pedal (left) that produce a range of expressive effects like those produced by the pedals of an acoustic piano.

2. Using the Pedals

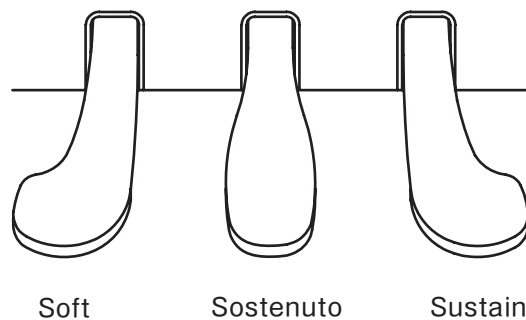

1) Sustain pedal

The sustain pedal functions in the same way as a damper pedal on an acoustic piano. When the damper pedal is pressed, notes sustain longer. Releasing the pedal immediately stops any sustained notes.

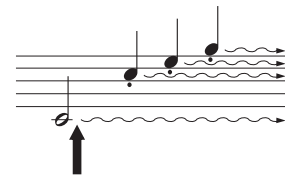

When you press the sustain pedal here, the notes you play before you release the pedal sustain longer.

2) Sostenuto pedal

If you play a note or chord on the keyboard and press the sostenuto pedal while the notes are held, those notes will sustain as long as you hold the pedal (as if the damper pedal had been pressed) but all subsequently played notes will not be sustained. This makes it possible to sustain a chord, for example, while other notes are played "staccato".

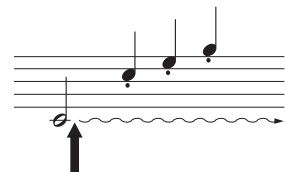

When you press the sostenuto pedal here, while holding the note, the note will sustain as long as hold the pedal.

3) Soft pedal

The soft pedal reduces the volume and slightly changes the timbre of notes played while the pedal is pressed. The soft pedal will not affect notes that are already playing when it is pressed.

NOTE If the pedal doesn't work, make sure that the pedal cord is properly plugged into the main unit (see page 10)

MIDI is acronym for Musical Instrument Digital Interface, which is an industry standard protocol for electronic instruments to communicate with each other.

1. MIDI Channel

A MIDI cable can transmit multiple channels of performance data which is similar to TV channels. Each channel can be assigned its own voice. Typical MIDI instruments can play up to 16 channels at the same time which is equivalent to 16 soloists.

NOTE

If you want to use your piano and record your performances with a computer, a sequencer program must be installed on your computer.

2. Connecting to a Computer



Type A



Type B

The instrument can be connected to the computer via a USB cable (AB type USB cable of less than 3 meters).

Connect the USB cable to the USB Type B terminal of the instrument, then to the USB Type A terminal of the computer.

MIDI Implementation Chart

Manufacturer:
KURZWEIL

Date : 5/15/2015
Version 1.0

Function	Transmitted	Recognized	Remarks
Basic Channel	Default	1	Memorized
	Changed	1 - 16	
Mode	Default	Mode 3	Use Multi mode for multi-timbral applications
	Messages		
	Altered		
Note Number		0 - 127	
	True Voice	0 - 127	
Velocity	Note ON	O	
	Note OFF	O	
After Touch	Keys	X	
	Channels	O	
Pitch Bender		O	
Control Change	O 0 - 31 32 - 63 (LSB) 64 - 127	O 0 - 31 32 - 63 (LSB) 64 - 127	
Program Change		O 0 - 19	
	True #	0 - 127	
System Exclusive ID : 18		O*	
System Common	Song Pos.	O	
	Song Sel.	O	
	Tune	X	
System Real Time	Clock	O	
	Messages	O	
Aux Messages	Local Control	X	O
	All Notes Off	X	O
	Active Sense	X	X
	Reset	X	X
Notes			

Chapter 13 Connection

1. Using Headphones

Connect a pair of headphones to one of the phones jacks. Two phones jacks are provided. You can connect two sets of standard stereo headphones. (If you are using one of pair headphones, you can plug them into either of these jacks).

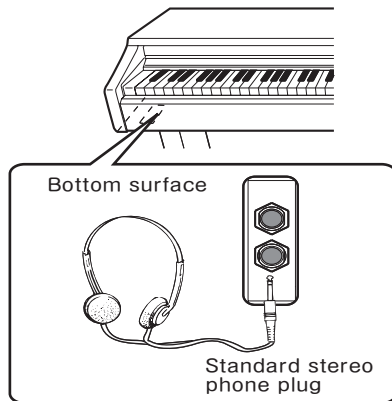

CAUTION

Do not use headphones at a high volume for an extended time. Doing so may cause hearing loss.

2. Audio In (Aux In)

You can connect the output jacks of an external device (such as CD player, tone generator) to the instrument's Aux In jacks, letting you hear the sound of that device through the built-in speakers of the instrument.

3. Audio Out (Aux Out)

You can connect a stereo system to amplify the instrument's sound by using the Aux Out jacks. When the instrument's sound is output to an external device, first turn on the power to the instrument, then to the external device. Reverse this order when you turn the power off.

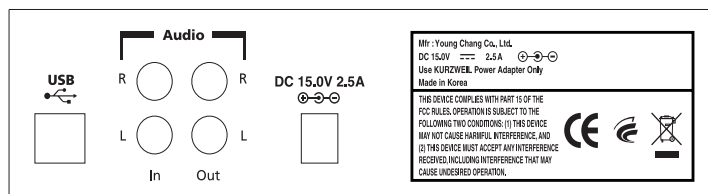

4. MP3 Aux In

You can connect the output jack of an MP3 player or smart phone to the instrument's MP3 Aux In jack on the right side of the front panel.



Chapter 14 Demo Song List

1		Prelude I BWV 846	J.S.Bach
2		Invention No.4	J.S.Bach
3		Invention No.8	J.S.Bach
4	BMV 847	Prelude II BWV 847	J.S.Bach
5		ARIA Goldenberg-Variationen BMW 988	J.S.Bach
6	BMV 848	Fuga II (A3 VOCl)	J.S.Bach
7	Op36, No4	Sonatine Op.36 No.4	M.Clementi
8	K15v	Klavierstück K. 15v	W.A. Mozart
9	K333	Piano Sonate K.333 1st mov.	W.A. Mozart
10	K485	Rondo in D-dur K.485	W.A. Mozart
11		Piano Sonate K.331 Rondo Turkish March	W.A. Mozart
12	K545	Piano Sonate K.545 1st mov.	W.A. Mozart
13		Minuette in G	L.v. Beethoven
14		Bagatelle No.25 Fur Elise	L.v. Beethoven
15	Op55, No. 1	Sonatine Op.55 No.1	Fr.Kuhlau
16		March Militaire Op.51 No.1	F.P.Schubert
17	Op94 - 3	Moments Musicaux 3.	F.P.Schubert
18	Op90 - 2	Impromptu Op.90 N0.2	F.P.Schubert
19	Op90 - 4	Impromptu Op.90 N0.4	F.P.Schubert
20		La chevaleresque	J.F.Buramu ler
21	Op38.No.2	Without words song Op.38 No.2	J.L.F.Mendelssohn
22	Op30.No.6	Venetianisches Zgondellied	J.L.F.Mendelssohn
23	KK Ivb-10	Sostenuto	F.F.Chopin
24	KK Ivb-11	Valse KK IVB-11	F.F.Chopin
25	Op.7.No.1	5 Mazurkas I Op.7 N0.1	F.F.Chopin
26	Op.69-2	Valse Op.69 No.2	F.F.Chopin
27	Op18	Grande Valse Brillante Op.18	F.F.Chopin
28		Valse Op.64. No.2	F.F.Chopin
29	Op9. No.2	Noctutne Op.9 N0.2	F.F.Chopin
30	Op64 No.1	Valse Op.64 No.1	F.F.Chopin
31	Op28.No.15	Preludes in Db Maior Op.28 No.15	F.F.Chopin
32	Op66	Fantaisie-Impromptu Op.66	F.F.Chopin
33	Op15-7	Traumerei	R. Schumann
34		Frolicher Landmann Op.68-10	R. Schumann
35	Op15	Von fremden Landern und Menschen Op.1	R. Schumann
36		Liebstraume Nr.3	F. Liszt
37		Dolly's Dreaming And Awakening	T. Oesten
38	Op410	Fryhlingsstimmen Op.410	J. Strauss
39		The Swan	Saint-Saens
40		Blumenlied	G. Lange
41		Valsette	F. Borowski
42	Op39, No.16	Old French Air	P.I.Tchaikovsky
43	Op39, No.10	Mazurka	P.I.Tchaikovsky
44		Polka	P.I.Tchaikovsky
45		Barcarolle	P.I.Tchaikovsky
46	Op101-7	Humoreska	A. Dvor A k
47	Op46-3	Suite Peer Gynt Op.46-3 Anitras Tanz	E. Grieg
48	L75	Suite Bergamasque Prelude	C.A.Debussy
49		Reverie	C.A.Debussy
50		Arabesque	C.A.Debussy

Chapter 15 Drum Sets

Keyboard	Pro 1: Standard Set	Pro 9: Room Set	Pro 17: Power Set	Pro 25: Elec. Set	Pro 26: TR808 Set
	D# 1	High Q			
	E 1	Slap			
	F 1	Stratch Push			
	F# 1	Stratch Pull			
	G 1	Sticks			
	G# 1	Square Click			
	A 1	Metronome Click			
	A# 1	Metronome Bell			
	B 1	Bass Drum 2 (Acoust)			
	C 2	Bass Drum 1 (Rock)	Power Kick	Elec Kick	808 Bd
	C# 2	Side Stick			808 Rim shot
	D 2	Snare Drum 1	Gated Snare	Gated Snare	808 Snare Drum
	D# 2	Hand Clap			
	E 2	Snare Drum 2		Elec Snare1	
	F 2	Low Floor Tom	Power Low Tom2	Power Low Tom2	Elec Low Tom2
	F# 2	Closed Hi Hat (EXC 1)			808 Low Tom2
	G 2	Hi Floor Tom	Power Low Tom1	Power Low Tom1	Elec Low Tom1
	G# 2	Pedal Hi Hat (EXC 1)			808 CHH[EXC1]
	A 2	Low Tom	Power Mid Tom1	Power Mid Tom2	Elec Mid Tom2
	A# 2	Open Hi Hat (EXC 1)			808 CHH[EXC1]
	B 2	Low-Mid Tom	Power Mid Tom2	Power Mid Tom1	Elec Mid Tom1
	C 3	Hi Mid Tom	Power Hi Tom2	Power Hi Tom1	Elec Hi Tom1
	C# 3	Crash Cymbal 1			808 Hi tom2
	D 3	High Tom	Power Hi Tom1	Power Hi Tom1	Elec Hi Tom1
	D# 3	Ride Cymbal 1			808 Cymbal
	E 3	Chines Cymbal		Reverse Cymbal	
	F 3	Ride Bell			
	F# 3	Tambourine			
	G 3	Splash Cymbal			
	G# 3	Cowbell			808 Cowbell
	A 3	Craxh Cymbal 2			
	A# 3	Vibraslap			
	B 3	Ride Cymbal 2			
	C 4	Hi Bongo			
C	C# 4	Lo BONGO			
	D 4	Mute Hi Conga			808 High Conga
	D# 4	Open Hi Conga			808 Mid Conga
	E 4	Low Conga			808 Low Conga
	F 4	Hi Timbal			
	F# 4	Low Timbal			
	G 4	High Agogo			
	G# 4	Low Agogo			
	A 4	Cabasa			
	A# 4	Maracas			808 Maracas
	B 4	Short Whistle (EXC 2)			
	C 5	Low Whistle (EXC 2)			
	C# 5	Short Guiro (EXC 3)			
	D 5	Long Guiro (EXC 3)			
	D# 5	Claves			808 Claves
	E 5	Hi Wood Block			
	F 5	Low Wood Block			
	F# 5	Mute Cuica (EXC 4)			
	G 5	Open Cuica (EXC 4)			
	G# 5	Mute Triangle (EXC 5)			
	A 5	Open Triangle (EXC 5)			
	A# 5	Shaker			
	B 5	Jingle Bell			
	C 6	Belltrees			
	C# 6	Castanets			
	D 6	Mute Surdo (ESC 6)			
	D# 6	Open Surdo (ESC 6)			

Notes :

- 1) * : No Sound
- 2) Blank : Same sound as "Standard Set"
- 3) Except "Pro 1" : Available from USB MIDI with channel 10

	Pro 33: Jazz Set	Pro 41: Brush Set	Pro 49: Ochestra Set	Pro 57: SFX Set
D# 1			Closed Hi Hat	*
E 1			Pedal Hi Hat	*
F 1			Open Hi Hat	*
F# 1			Ride Cymbal	*
G 1				*
G# 1				*
A 1				*
A# 1				*
B 1	Zazz BD2	Zazz BD2	Concert BD2	*
C 2	Zazz BD1	Zazz BD1	Concert BD1	*
C# 2				*
D 2		Brush Tap	Concert SD	*
D# 2		Brush Slap	Castanets	High Q
E 2		Brush Swir1	Concert SD	Slap
F 2			Timpani F	Scratch Push
F# 2			Timpani F#	Scratch Pull
G 2			Timpani G	Sticks
G# 2			Timpani G#	Square Click
A 2			Timpani A	Metronome Click
A# 2			Timpani A#	Metronome Bell
B 2			Timpani B	Guitar Slide
C 3			Timpani c	Gt Cut Noise(down)
C# 3			Timpani c#	Gt Cut Noise(up)
D 3			Timpani d	Double Bass Slap
D# 3			Timpani d#	Key Click
E 3			Timpani e	Laughing
F 3			Timpani f	Screaming
F# 3				Punch
G 3				Heart Beat
G# 3				Footsteps1
A 3			Concert Cymbal2	Footsteps2
A# 3				Applause
B 3			Concert Cymbal1	Door Creaking
C 4				Door Closing
C# 4				Scratch
D 4				Wind Chime
D# 4				Car Engine Start
E 4				Car Breaking
F 4				Car Pass
F# 4				Car Crash
G 4				Police Siren
G# 4				Train
A 4				Jet Take-off
A# 4				Helicopter
B 4				Starship
C 5				Gun Shot
C# 5				Machinegun
D 5				Lasergun
D# 5				Explosion
E 5				Dog
F 5				Horse Gallop
F# 5				Birds
G 5				Rain
G# 5				Thunder
A 5				Wind
A# 5				Sea Shore
B 5				Stream
C 6				Bubble
C# 6				*
D 6				*
D# 6				*

Notes :

- 1) * : No Sound
- 2) Blank : Same sound as "Standard Set"
- 3) Except "Pro 1" : Available from USB MIDI with channel 10

Chapter 16 Specifications

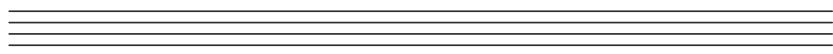

Keyboard	88 Dynamic Touch Graded Hammer action keys
Finish	Simulated Rosewood or White
Cabinet	Pattern type
Polyphony	128 Voices
Sound	20 Programs (Available 128 GM with USB MIDI)
Rhythm	12 Styles
Play Mode	Layer, Split, Dual(Duo)
Touch	4 Sensitivity levels
Demo Songs	50 Piano Masterpieces
Sequencer	1 Track, 20,000 notes
Pedals	3 (Sustain, Soft, Sostenuto)
Display	3 x 7 Segment LED
Others	Volume, Tune, Transpose, Metronome
Connectors	MP3 Aux In, Audio In/Out, USB MIDI
Audio Power	15W x 2, 8 Ohms
Speaker	4.5" x 2 full-range (Oval type)
Dimension	1384 x 415 x 837 (W x D X H)
Weight	Keyboard : 29Kg, Stand : 22Kg with packing

KURZWEIL

www.ycpiano.co.kr

KURZWEIL

**HDC YOUNG CHANG
MUSIC**

American Music & Sound

5304 Derry Avenue #C, Agoura Hills, California 91301 USA
telephone: (800) 994-4984
fax: (818) 597-0411

Kurzweil Co., LTD

iPark Building #102, Floor 9 Jeongja-Dong 9, Bundang-Gu
Soungnam-Shi, Gyeonggi-Do 463-859 South Korea
www.ycpiano.co.kr
www.youngchang.com
www.kurzweil.com

TECHNICAL SUPPORT

Email : support@Kurzweil.com