

Mechanical Dimensions

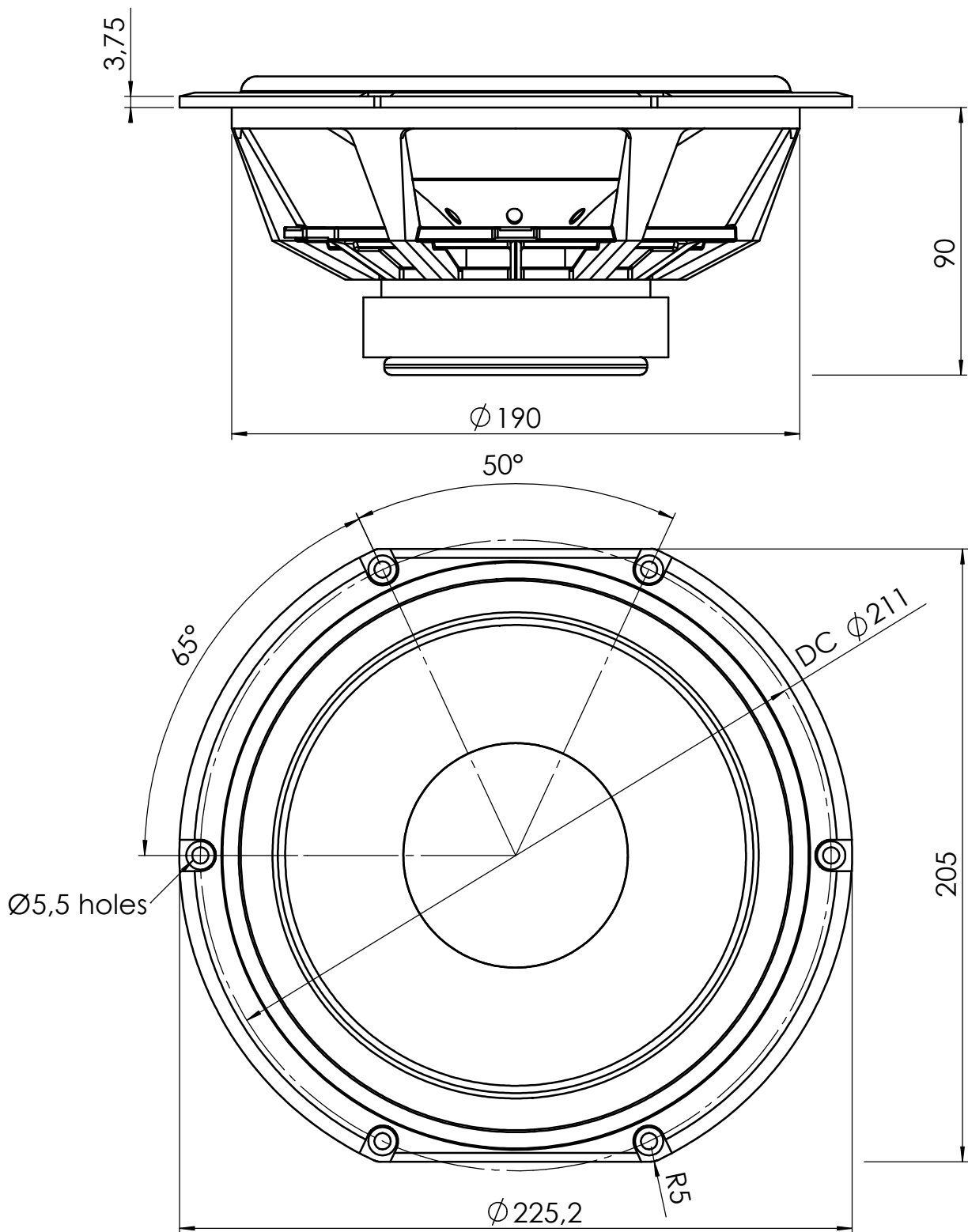

* Dimensions listed are maximum production line values !

* Recommended build in clearance : 0,5% of above values !

Drawing Scale **1:2** All dimensions are in millimeters !

The rights to make changes are reserved by DST A/S



Danish Sound Technology A/S
 Motorgangen 2-4, 2690 Karlslunde
 Tlf.: +045 7028 1700 Fax.: +45 4615 1171
 Website: www.d-s-t.com

8" HDS cut (Die Cast Aluminium)

Order ID. **830869**



Peerless Data Sheet

Type: HDS NOMEX 205 WR 33 102 NWP AL 4L LS 8 OHM - 830869



Electrical data

Nominal impedance	Zn	8 (ohm)
Minimum imp./at freq.	Zmin	6.9/224 (ohm/Hz)
Maximum impedance	Zo	81.5 (ohm)
Dc resistance	Re	6.0 (ohm)
Voice coil inductance	Le	1.8 (mH)

TS Parameters

Resonance Frequency	fs	29.5 (Hz)
Mechanical Q factor	Qms	3.94
Electrical Q factor	Qes	0.31
Total Q factor	Qts	0.29

Force factor	Bl	9.6 (Tm)
Mechanical resistance	Rms	1.22 (Kg/s)
Moving mass	Mms	25.9 (g)
Suspens. compliance	Cms	1.13 (mm/N)
Effective cone diam.	D	16.8 (cm)
Effective piston area	Sd	221 (cm ²)
Equivalent volume	Vas	76.1 (ltrs)
SPL 2.83V/1m at fmin		90.0 (dB)

Power handling

100h RMS noise test (IEC)	- (W)
Longterm Max System Power (IEC)	- (W)
IEC268-5 noise signal is used for the powertest.	

Voice coil and magnet parameters

Voice coil diameter	33.0 (mm)
Voice coil length	17.0 (mm)
Voice coil layers	4
Height of the gap	6.0 (mm)
Linear excursion +/-	5.5 (mm)
Max mech. excursion +/-	- (mm)
Total useful flux	1.03 (mWb)
Diameter of magnet	102 (mm)
Height of magnet	20 (mm)
Weight of magnet	0.68 (kg)

Factors

Ratio fs/Qts	102
Ratio BL/sqrt(Re)	3.9

Special remarks

-

Remarks on powertest

-

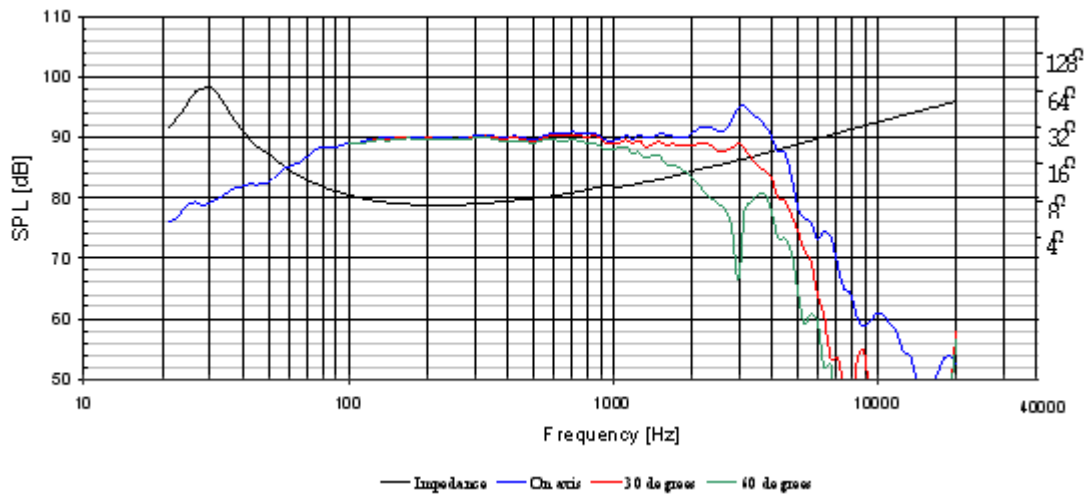

Measuring methods and conditions are stated in Peerless Standard for Acoustic Measurements (PSAM)