

VRx audison

2000 EDITION

Owner's manual



Power amplification integrated system for cars

audison
is a division of **elettromedia**

* NP - Nominal Power (+10%, -5%) @ 4Ω - 12V - 0.3% THD.

AMPLIFIERS		VRx 1.500	VRx 2.150	VRx 2.250	VRx 2.400	VRx 4.300	VRx 6.420
Number of channels		1	2	2	2	4	6
Nominal Power @ 12V *	W	500x1	75x2	125x2	200x2	75x4	65x4 + 80x2
6 ch. mode - 4Ω	W						75x4 + 85x2
6 ch. mode - 2Ω	W						120x4 + 150x2
6 ch. mode - 4/2Ω	W						75x4 (4Ω) + 165x2 (2Ω)
6 ch. mode - 4/1Ω	W						75x4 (4Ω) + 250x2 (1Ω)
5 ch. mode - 4Ω	W						75x4 + 330x1
5 ch. mode - 4/2Ω	W						75x4 (4Ω) + 500x1 (2Ω)
5 ch. mode - 2Ω	W						110x4 + 430x1
4 ch. mode - 4Ω	W					110x4	
4 ch. mode - 2Ω	W					175x4	
4 ch. mode - 1Ω	W					220x4	
3 ch. mode - 4Ω	W					102x2 + 380x1	
3 ch. mode - 4/2Ω	W					90x2 (4Ω) + 530x1 (2Ω)	
2 ch. mode - 4Ω	W		110x2	160x2	250x2	350x2	
2 ch. mode - 2Ω	W		180x2	280x2	450x2	440x2	
2 ch. mode - 1Ω	W		240x2	420x2	580x2		
1 ch. mode - 4Ω	W	560x1	360x1	560x1	900x1		
1 ch. mode - 2Ω	W	1080x1	480x1	840x1	1160x1		
1 ch. mode - 1Ω	W	2000x1					
Distortion - THD (1 KHz)	%	0.02	0.02	0.02	0.02	0.02	0.02
A weighed S/N ratio	dBA	100	100	100	100	100	100
Hi-Lo input sensitivity	VRMS	0.15-1.5/0.5-5	0.15-1.5/0.5-5	0.15-1.5/0.5-5	0.15-1.5/0.5-5	0.15-1.5/0.5-5	0.15-1.5/0.5-5
Use in bridge			✓	✓	✓	✓	✓
Use in tri-mode			✓	✓	✓	✓	✓
Stereo load impedance	Ω		8-4-2-1	8-4-2-1	8-4-2-1	Ch.A & Ch.B: 8-4-2-1	Ch.A & Ch.B: 8-4-2; Ch.C: 8-4-2-1
Mono/bridge load impedance	Ω	8-4-2-1	8-4-2	8-4-2	8-4-2	Ch.A & Ch.B: 8-4-2	Ch.A & Ch.B: 8-4; Ch.C: 8-4-2
PRM3 option		✓	✓	✓	✓	✓✓	✓✓✓
SM24 option		✓	✓	✓	✓	✓	✓
PC36 option		✓	✓	✓	✓	✓	✓
DSC1 option		✓					
BTX2 option		✓	✓	✓	✓	✓	✓
VCRDK option		✓	✓	✓	✓	✓	✓
HL12 option		✓	✓	✓	✓		
BH12 option			✓	✓	✓		
LM24 option		✓	✓	✓	✓		
HL24 option		✓	✓	✓	✓		
BSA1 option		✓	✓	✓	✓		
MAC2 option - with TRM or RC		✓	✓	✓	✓	✓	✓
TRM4 - TRM6 option		✓	✓	✓	✓	✓	
RC08 - RC10 - RC12 option		✓	✓	✓	✓	✓	✓

MULTICHANNEL EXTENSIONS		HL12	BH12	LM24	HL24	BSA1
		HI/LO-PASS	BAND/HI-PASS	LO-PASS MONO	HI-PASS STEREO LO-PASS MONO	BALANCED PRE OUT
DEPENDENT ADJUSTMENTS		✗	✗	✗	✗	—
INDEPENDENT ADJUSTMENTS		✓	✓	✓	✓	—
CROSSOVER SLOPE	dB/oct.	12	12	24	HI-PASS 12/LO-PASS 24	
CUT OFF FREQUENCIES	Hz	40-5k	BAND-PASS LO 40-2k BAND-PASS HI 150-5k HI-PASS 150-5k	40-90	LO-PASS 40-90 HI-PASS 40-120	
CONTINUOUS ADJUSTMENTS		✓	✓	✓	✓	
AMP-OUT/PRE-OUT SWITCHING		✓	✓	✓	✓	
PRE-OUT FUNCTION		HI-PASS; LO-PASS; BYPASS	HI-PASS; BYPASS	LO-PASS; BYPASS	HI-PASS; LO-PASS; BYPASS	BYPASS

CONTROL EXTENSIONS	
PRM3	ONE BAND PARAMETRIC EQUALISER WITH CONTINUOUS CONTROLS FOR: FREQUENCY (SELECTABLE IN THREE STEPS, FROM 20HZ TO 20KHZ), GAIN (-9DB, +9DB), BAND WIDTH (Q FROM 1 TO 4). BY-PASS SWITCH.
SM24	24DB/OCT. MONO SUBSONIC FILTER. CONTINUOUSLY ADJUSTABLE FREQUENCY BETWEEN 14 AND 36HZ. BY-PASS SWITCH.
PC36	ANALOGUE PHASE CONTROL. CONTINUOUSLY ADJUSTABLE PHASE BETWEEN 0° AND 360°, SELECTION ON THREE FREQUENCY RANGES (40-200 HZ; 200-800 HZ; 800-4500 HZ). BY-PASS SWITCH.
DSC1	AUTOMATIC DYNAMIC PROCESSOR FOR SUBWOOFER RESPONSE CONTROL.
VCRDK	SYSTEM FOR MASTER VOLUME REMOTE CONTROL IF USED IN BTX2 OR FOR LEVEL CONTROL OF ANY WAYS IN A MULTIAMPLIFIED SYSTEM IF USED IN VRX. BASED ON VCA1D WITH DIGITAL CONTROL.
VCA1D	ADDITIONAL MODULE FOR CONTROLLING SEVERAL CHANNELS. IF IT IS MOUNTED IN A FURTHER BTX2, IT CONTROLS ALSO REAR CHANNEL WITH ONLY ONE VCRDK.
BTX2	ABS BALANCED LINE TRANSMITTER. THREE STEP GAIN CONTROL (0DB, +3DB, +6DB) AND PEAK LED. OPTIONAL VCA MODULE FOR LEVEL CONTROL. YOU CAN REALISE MASTER VOLUME IN FRONT/REAR SYSTEMS USING TWO BTX2, ONE VCRDK AND ONE VCA1D.
MAC2	GRADUAL INTERVENTION COOLING SYSTEM CONTROLLED BY THE AMPLIFIER TEMPERATURE. MIN. STARTING THRESHOLD TEMPERATURE: 44 °C; MAX. EFFICIENCY TEMPERATURE: 74 °C. IT CONSISTS OF TFC CONTROLLER MODULE TO MOUNT INSIDE THE AMPLIFIER AND TWO FANS GROUPS, TO PLACE INTO A TERMINAL OR A RACCORD.

COOLING DUCT EXTENSIONS	
TRM4	HOUSING DUCTS FOR MAC2 FANS.
TRM6	
RC08	
RC10	
RC12	
TRM4	TERMINALS FOR PROTECTING CONNECTIONS; IT IS POSSIBLE TO INVERT THEIR FRONT PANEL IN ORDER TO FIX THEM WITH HIDDEN SCREWS.
TRM6	
RC08	
RC10	
RC12	

AUDISON'S MEASUREMENT STANDARDS

Power measures taken according to audison standard 1998 edition.

- 12 VDC and 13.8 VDC.
- 1 kHz or crossover cut-off frequency.
- 0.3 % THD nominal power; 1% THD continuous power.
- Tolerance: + 10 %; -5 %.
- Continuous power given by RMS Voltage measured on resistive load.
- The nominal power of the amplifier is measured upon a battery voltage of 12 Volts with a 4 Ohm load and with all channels in function.

VRx6.420 connections

Power supply, remote and accessories

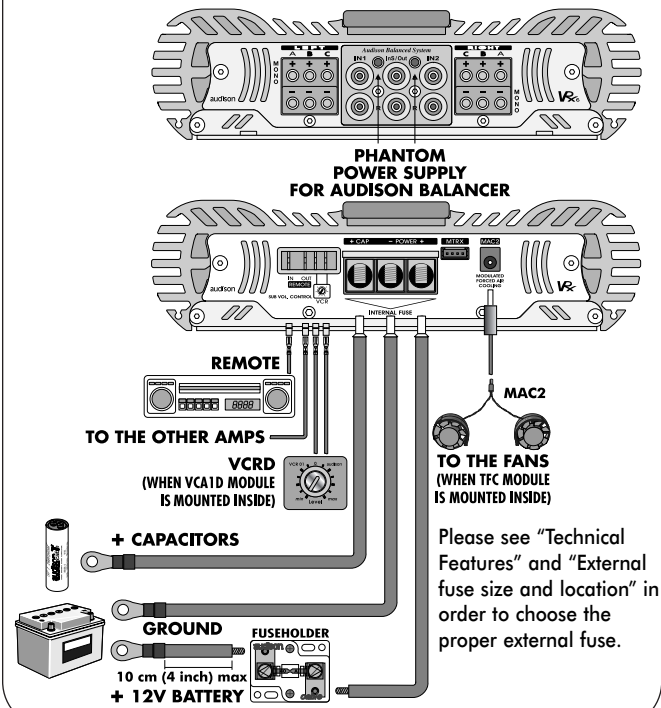

Inputs and outputs: stereo connection

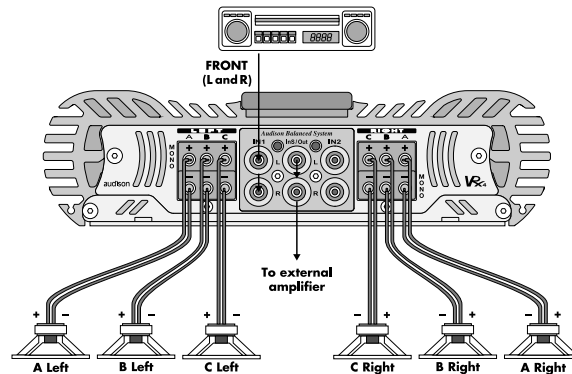

Inputs and outputs: connection with C amplifiers in bridge

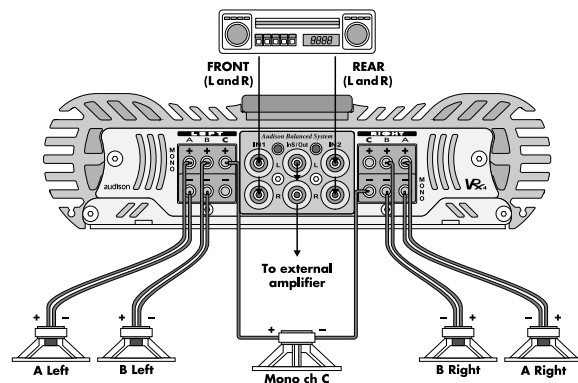

Inputs and outputs: connection with A, B and C amplifiers in bridge

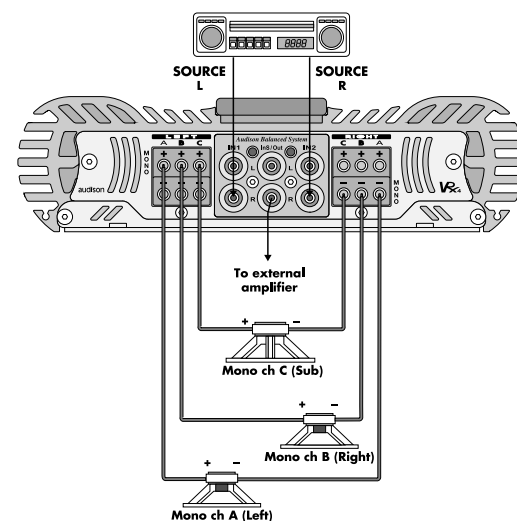

- Objectives of VRx project p. 2
- General features p. 3
- VRx - MODULAR EXTENSIONS: CONTROL EXTENSIONS
 - PRM3 stereo parametric equaliser p. 6
 - SM24 24 dB/oct. mono subsonic filter p. 6
 - PC36 360° phase controller p. 7
 - DSC1 sub dynamic control p. 8
 - VCRDK digital remote volume control kit (VCRD + VCA1D) p. 8
 - MAC2 forced air modulated cooling system p. 9
 - Insertion of fans group into Terminals and Raccords p. 10
 - BTX2 stereo balancer/preamplifier p. 11
- VRx - MODULAR EXTENSIONS: MULTICHANNEL EXTENSIONS
 - HL12 12 dB/oct. HI/LO-PASS crossover p. 14
 - BH12 12 dB/oct. BAND/HI-PASS crossover. p. 15
 - LM24 24 dB/oct. LO-PASS mono crossover p. 16
 - HL24 12 dB/oct HI-PASS - 24 dB/oct. LO-PASS crossover p. 17
 - BSA1 Stereo balanced pre-out repeater p. 18
 - Updating of short guide under wooden strip p. 19
- VRx - MODULAR EXTENSIONS: COOLING DUCT EXTENSIONS
 - Terminals and Raccords p. 22
 - Terminals: Installation of TRM4 - TRM6 p. 23
 - Raccords: Installation of RC08 - RC10 - RC12. p. 24
 - Wooden strip removal - Logo rotation p. 25
- VRX INSTALLATION
 - General recommendations p. 28
 - Cables size p. 29
 - External fuse size and location p. 30
 - Internal fuse replacement p. 31
 - VRx size p. 32
- VRx - 1.500
 - Technical features p. 34
 - Block diagram p. 35
 - Controls and functions p. 36
 - Short guide under wooden strip p. 37
 - Where to put modular extensions p. 38
 - VRx 1.500 connections p. 39
- VRx - 2.150 - 2.250 - 2.400
 - Technical features p. 42 - 44
 - Block diagram p. 45
 - Controls and functions p. 46
 - Short guide under wooden strip p. 47
 - Where to put modular extensions p. 48 - 49
 - VRx 2.150 - 2.250 - 2.400 connections p. 50
- VRx - 4.300
 - Technical features p. 52
 - Block diagram p. 53
 - Controls and functions p. 54
 - Short guide under wooden strip p. 55
 - 12dB/oct. Sub filter slope configurations p. 56
 - 24dB/oct. Mono Sub filter slope configurations p. 57
 - Where to put modular extensions p. 58
 - VRx 4.300 connections p. 59
- VRx - 6.420
 - Technical features p. 62
 - Block diagram p. 63
 - Controls and functions p. 64
 - Short guide under wooden strip p. 65
 - Configurations: front/rear, multichannel, A-B-C amplifiers in bridge p. 66
 - Where to put modular extensions p. 67
 - VRx 6.420 connections p. 68
- Audison's measurement standards p. 69

OBJECTIVES OF VRx PROJECT

VRx project was conceived in order to solve the problems which derive from the installation of a high quality car audio system. The long and constant work made with professional installers and the use of the most advanced, currently available technology allowed **audison's** designers to attain totally new results in terms of power, reliability and exceptional versatility above all. "VRx SYSTEM" derived from this: it is a complete line of integrated electronic circuits made by amplifiers, active crossovers and signal processors, characterised by a common conceptual system called **Open Deck Construction**.

Open Deck Construction

It's the heart of VRx SYSTEM. It indicates the "totally open construction" of VRx SYSTEM. A sophisticated pre section can accept several modules (MODULAR EXTENSIONS) which are put before the amplifiers and allow their functioning configuration. The integration between amplifier and signal processors permits to reduce signal paths as much as possible and to obtain performances which are not commonly attained through separate units.

Modular Extensions

They are divided into:

- **CONTROL EXTENSIONS:** signal processing and control modules and cooling modules. They can be used into all VRx.
- **MULTICHANNEL EXTENSIONS:** crossover modules which can be employed in one and two channel amplifiers (VRx1 and VRx2). Multichannel VRx (VRx4 and VRx6) are already supplied with a sophisticated, re-configurable crossover.
- **COOLING DUCT EXTENSIONS:** terminals and raccords which allow air ducting inside and outside the heat sink, directing its flux in order to improve cooling. If cooling modules are not used, Cooling Duct Extensions can be employed for esthetical purposes.

ABS® - AUDISON BALANCED SYSTEM

All VRx amplifiers have balanced inputs and, if supplied with integrated crossover or Multichannel Extensions, they also have balanced outputs. They use **audison cable ABS** connectors, which allow balanced connection through an exclusive panel connector which is as big as standard RCA ones. They can accept signals up to 5V, in order to be as compatible as possible with all sources which can be found into the market.

VRx AMPLIFIER

While developing VRx project, utmost attention was paid to the following aspects:

- dynamics, which involves power supply and amplifying stage
- reliability and, thus, protection and cooling
- sound quality.

VRx amplifiers have high power, which can guarantee very good dynamics even in car. In order to be able to do this, power supply is oversized and has the same structure as **HV** series one.

Power supply is protected from overloads and excessive voltages (due to the car voltage controller breakdown or to the battery charger fault, for instance). Protection against short circuits or against too low loads onto speakers outputs were also introduced, as well as in case there is direct current on power signal.

Thermal protection is double: it traditionally controls heat sink temperature but also power supply transformers one.

In order to achieve the best sound quality, VRx use totally symmetrical, pure A class refined drivers made with discrete components. These are mounted onto separate printed circuit boards with heat sink; this solution guarantees optimal thermal stability.

Final stages use complementary inverted triplets of bipolar transistors. These components were judged better than mosfets since they permit to obtain more linearity with the same power.

The accurate calibration of all these designing elements allowed the limitation of feedback factor below 15dB and, thus, the achievement of outstanding sound features.

WHERE TO PUT MODULAR EXTENSIONS

VRx6.420

VRX6CD-S VRx6 controls. They must not be removed.

LD1 VRx6 driver stages. They must not be removed.

CONTROL EXTENSIONS
PC36

CONTROL EXTENSIONS
SM24

CONTROL EXTENSIONS
PRM3 for A channels

PRM3 for B channels

PRM3 for C channels

CONTROL EXTENSIONS
Socket for:





VCA - VCA1D, given with VCRDK

DMRX socket for a future extension. Do not put any modules into it.

TPC VRx6 power supply controller. It must not be removed.

CONTROL EXTENSIONS
TFC

(supplied with MAC2)

	Serial modules
	Modular Extensions
	BYP08 bridge: 4+4 Pins
	BYP12 bridge: 6+6 Pins

Controls under wooden strip

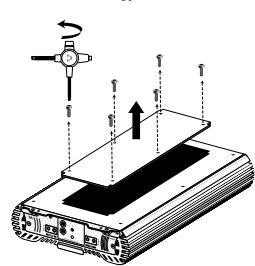
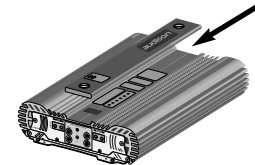
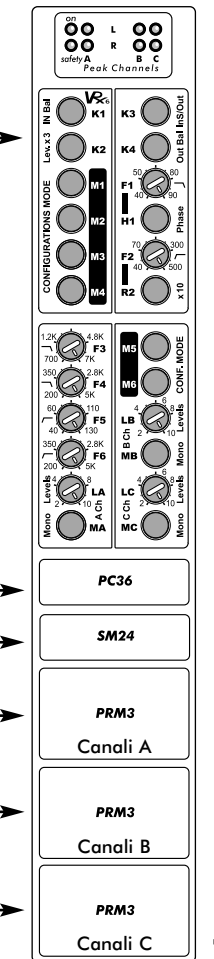

VRx6.420

Front/Rear configurations

N°	A Channels	B Channels	C Channels	PRE OUT	IN SUB	INPUTS		CONFIGURATION MODE						MONO - STEREO			
	Ch	2 x 65 W	2 x 65 W	2 x 80 W	Out - K3	InS - K3	IN1	IN2	M1	M2	M3	M4	M5	M6	MA	MB	MC
5/6	HI FRONT /F5	HI REAR /F2	▲ SUB 24 dB F1 BRIDGE 300Wx1	▲ SUB 24 dB F1	IN SUB	Front IN (R)	Rear IN (R)	→									
5/6	◆ WOOFER FRONT /F5 F4	◆ MID & TW FRONT /F6	▲ SUB 24 dB F1 BRIDGE 300Wx1	HI REAR /F2	IN SUB	Front	Rear Not used →	→									
6	◆ MID & TW FRONT /F6	HI REAR /F2	◆ WOOFER FRONT /F5 F4	▲ SUB 24 dB F1	IN SUB	Front	Rear Not used →	→									
5/6	◆ MID & TW FRONT /F6	▲ SUB 24 dB F1 BRIDGE 200Wx1	◆ WOOFER FRONT /F5 F4	HI REAR /F2	IN SUB	Front	Rear Not used →	→									

Note: ◆ Channels are driven by PC36 (PC36 always takes signal from IN1)
▲ Sub is driven by IN1 + IN2 NO FADING SUB (with active Constant Bass)

Multichannel Configurations

N°	A Channels	B Channels	C Channels	PRE OUT	IN SUB	INPUTS		CONFIGURATION MODE						MONO - STEREO			
	Ch	2 x 65 W	2 x 65 W	2 x 80 W	Out - K3	InS - K3	IN1	IN2	M1	M2	M3	M4	M5	M6	MA	MB	MC
6	◆ MID FRONT /F6 F3	◆ TW FRONT /F2	◆ WOOFER FRONT /F5 F4	▲ SUB 24 dB F1	IN SUB	Front	Sub level → Not used →	→									
5/6	◆ WOOFER FRONT /F5 F4	◆ MID FRONT /F6 F3	▲ SUB 24 dB F1 BRIDGE 300Wx1	TW FRONT /F2	IN SUB	Front	Sub level → Not used →	→									
5/6	◆ MID FRONT /F6 F3	▲ SUB 24 dB F1 BRIDGE 200Wx1	◆ WOOFER FRONT /F5 F4	TW FRONT /F2	IN SUB	Front	Sub level → Not used →	→									

Note: ◆ Channels are driven by PC36 (PC36 always takes signal from IN1).
▲ Sub is driven by IN1 + IN2.
IN2 = **Sub level:** Sub is driven by IN1 + IN2. Fader is used to adjust sub level.
IN2 = **Not used:** Sub and Front driven by IN1.

A, B and C bridged amplifiers configurations

MA, MB and MC on position 2 (mono)

N°	A Channels	B Channels	C Channels	PRE OUT	IN SUB	INPUTS		CONFIGURATION MODE						MONO - STEREO			
	Ch	1 x 200W	1 x 200W	1 x 300W	Out - K3	InS - K3	IN1	IN2	M1	M2	M3	M4	M5	M6	MA	MB	MC
3	HI LEFT /F5	HI RIGHT /F2	SUB 24 dB F1	SUB 24 dB F1	IN SUB	Left IN (R)	Right IN (R)	→									

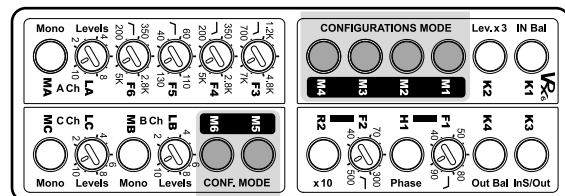

☐ = Pushed switch.
☐ = Released switch.
● = Switch involved in configurations.

GENERAL FEATURES

Conformity with "E" norms

VRx models have a RF filter which makes them suitable to the new norms about radio-frequency disturbances emission inside cars before any others. A "common mode", adequately dimensioned filter choke was inserted next to power supply input in order to prevent sudden voltage drops which commonly occur in similar circuit typologies.

Thermal limiter onto transformers

A very effective protection circuit was put onto transformers to prevent them from exceeding temperatures which might be dangerous for the amplifier integrity. This circuit intervenes by having VRx stop; the amplifier will start to function again only after the necessary cooling and reset operation (on and off again) will have to be carried out.

LNS (Line Noise Suppressor) circuit

LNS circuit allows the system low frequency disturbances rejection, reducing the ordinary noise due to car electrical parts (alternator, electronic injection, etc.). It does not affect sound and is effective in most cases. The special switch which is onto all models except VRx 6.420 (where it is not indicated since it is constantly active) permits to check if its intervention is necessary in case there are several VRx configured in cascade.

TPC.2 (Twin Power Controller) power supply stage handling system

TPC.2 allows to increase power supply stage handling speed (10 times approx.). This implies higher available impulsive power and lower stress of filter capacitors.

OCN (Off Current Null) and DVP (Damaging Voltage Protection) circuits

Thanks to OCN circuit, VRx models are the only ones to be in conformity with max absorption new standards when amplifier is off. Their value (0.00005A) makes them be 10 times below the maximum allowed limit. DVP circuit protects VRx amplifiers from voltage increases and electrostatic discharges.

Synchro-PWM power supply

Power supply stage consists of two totally separate and synchronised sections: one for positive and one for negative voltages. It is therefore possible to satisfy the final stage current demands more promptly, guaranteeing higher energy and speed with low frequencies.

Final stage driver modules: LD1.2 and DHF.1

Final stage driver modules (LD1.2 for VRx2-4-6; DHF.1 for VRx1) sum up all audison's experience of amplified sound characterisation. Subjected to continuous studies and improvements, they further increase linearity and acoustic impact with low frequencies in the current VRx version.

DFL (Distortion Frequency Limiter) circuit

DFL circuit is a real electronic protection for speakers. It limits max distortion factor to 6% onto low frequencies and to 2% onto high ones. This implies constant and systematic control onto all audio range and wide safety margin for all speakers in the system.

Sub input (VRx6.420)

VRx6.420 PRE OUT output can be used as IN Sub input in order to use this model with the head units which have a third preamplified output for the subwoofer, exploiting the amplifier internal filter.

RGP input stages protection (Resettable Ground Protection)

RGP is an electronic protection able to detect high direct current passage onto input ground; it acts by putting the device in "stand by" condition (safety). The main feature of this circuit is its being able to work even when the amplifier is off, allowing the interruption of current passage towards input stages in case of power supply transformers short circuit. It perfectly guarantees the system safety since it consists of several sensors.

Three way, big size terminal block

VRx terminal block can accept cables up to 2 gauge section. A third positive pole houses the external capacitor (+C) which, thus, directly acts onto power supply voltage seen by the amplifier. This minimises voltage drop and cable overheating. Fastening screws are protected by a polycarbonate door. Inside the terminal block there is also a location for a strip fuse which can be inspected through the device bottom, that protects electronic circuitry and external capacitor. This solution allows the installation to be cleaner and the terminal block-fuse holder system to have 300A approx. max capacity.

VRx6.420

Short guide under wooden strip

It shows internal crossover, outputs configurations and controls meaning

See owner's manual before any adjustment

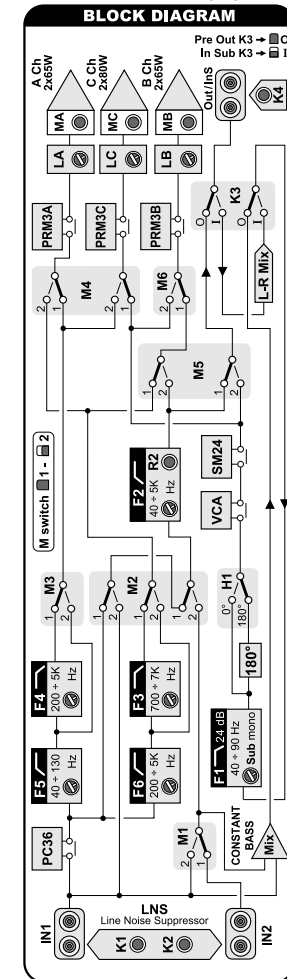

10125731

VRx6 controls

K1 B Balanced Mono in: IN1 IN2 Bal
 U Unbalanced R only

K2 H 0.15 + 1.5V IN sensitivity range
 L 0.5 + 5V

M1 1
 2

M2 1
 2

M3 1
 2

M4 1
 2

F3 2.8K 12 dB stereo Filter
 1.2K - 3.5K 800 700 - Hz -

F4 1.7K 12 dB stereo Filter
 350 240 200 1.8K 2.8K 4.2K 700 5K - Hz -

F5 90 12 dB stereo Filter
 70 60 50 100 110 120 130 - Hz -

F6 1.7K 12 dB stereo Filter
 600 240 200 1.8K 2.8K 4.2K 5K - Hz -

LA 4 6 8 A ch. level
 2 10 Range K2

MA M Mono - IN Right
 S Stereo

K3 I In Sub (K4 → U) InS Out
 O Pre Out (K4 → B/U) Pre Out Bal

K4 B Balanced Mono out: R only Pre Out Bal
 U Unbalanced

F1 70 75 80 Sub 24 dB mono Filter
 50 45 40 85 90 - Hz -

H1 180 180° Phase delay Filter
 0 0° Phase

F2 150 12 dB stereo Filter
 120 70 50 200 300 400 500 - Hz -

R2 x 10 400 Hz + 5 KHz Filter
 x 1 40 Hz + 500 Hz

M5 1
 2

M6 1
 2

LB 4 6 8 B ch. level
 2 10 Range K2

MB M Mono - IN Right
 S Stereo

LC 4 6 8 C ch. level
 2 10 Range K2

MC M Mono - IN Right
 S Stereo

Configurations short guide

No.	A Channels	B Channels	C Channels	PRE OUT	IN SUB	INPUTS	CONFIGURATION MODE						
							IN1	IN2	IN3	IN4	IN5	IN6	IN7
3	2 x 65 W	2 x 80 W	2 x 65 W	2x SUB	IN SUB	IN1	IN2	IN3	IN4	IN5	IN6	IN7	IN8
5/6	HI LEFT / F1	HI RIGHT / F2	HI LEFT / F1	2x SUB	IN SUB	IN1	IN2	IN3	IN4	IN5	IN6	IN7	IN8
5/6	HI LEFT / F1	HI RIGHT / F2	HI LEFT / F1	2x SUB	IN SUB	IN1	IN2	IN3	IN4	IN5	IN6	IN7	IN8
6	HI LEFT / F1	HI RIGHT / F2	HI LEFT / F1	2x SUB	IN SUB	IN1	IN2	IN3	IN4	IN5	IN6	IN7	IN8
5/6	HI LEFT / F1	HI RIGHT / F2	HI LEFT / F1	2x SUB	IN SUB	IN1	IN2	IN3	IN4	IN5	IN6	IN7	IN8
5/6	HI LEFT / F1	HI RIGHT / F2	HI LEFT / F1	2x SUB	IN SUB	IN1	IN2	IN3	IN4	IN5	IN6	IN7	IN8
5/6	HI LEFT / F1	HI RIGHT / F2	HI LEFT / F1	2x SUB	IN SUB	IN1	IN2	IN3	IN4	IN5	IN6	IN7	IN8

PC36 Continuous phase controller
YH ON PC36 on
 OFF PC36 by-pass
 40+200 Hz (factory preset); 200+800 Hz; 800+4500 Hz 3 pos. internal presets

SM24 Subsonic mono filter
WF ON SM24 on
 OFF SM24 by-pass

PRM3 A - PRM3 B - PRM3 C

Parametric equaliser

JF ON PRM3 on
 OFF PRM3 by-pass

JM ON Activates JX
 OFF 20 Hz + 200 Hz

JX x 100 2 KHz + 20 KHz
 x 10 200 Hz + 2 KHz

JL Level adjustment - dB

JQ Q adjustment

VRx6.420

Controls and functions

Controls description

- K1 - Bal/Unbal inputs** switch.
- K2** - It selects **sensitivity range** of all inputs.
- K3 - In Sub/Pre Out** switch. ABS sockets, normally used for Pre output, can be also employed as additional input for Sub.
- K4 - Bal/Unbal** switch for **PRE output**. It is possible to have a balanced output signal even with an unbalanced input one. Put **K4** on **B** (Balanced) only if **K3** is on **O** (Out)
- M1, M2, ..., M6** - Switches to select the amplifier functioning modes. M1, M2 and M3 act on crossover and on inputs connection; M4, M5 and M6 act on outputs. Please see the manual in order to use them; it indicates VRx6 main functioning modes.
- F1 - Mono LO-PASS filter** for sub, **24dB/oct.** slope.
- F2, F3, F4, F5, F6** - 12dB/oct. stereo crossover filters. The pairs (F4, F5) and (F3, F6) form two band-passes.
- LA, LB, LC** - Input **sensitivity adjustment** of A and B amplifiers pairs respectively.
- MA, MB, MC** - **Mono/Stereo** switches of A, B and C amplifiers respectively.

Controls under wooden strip

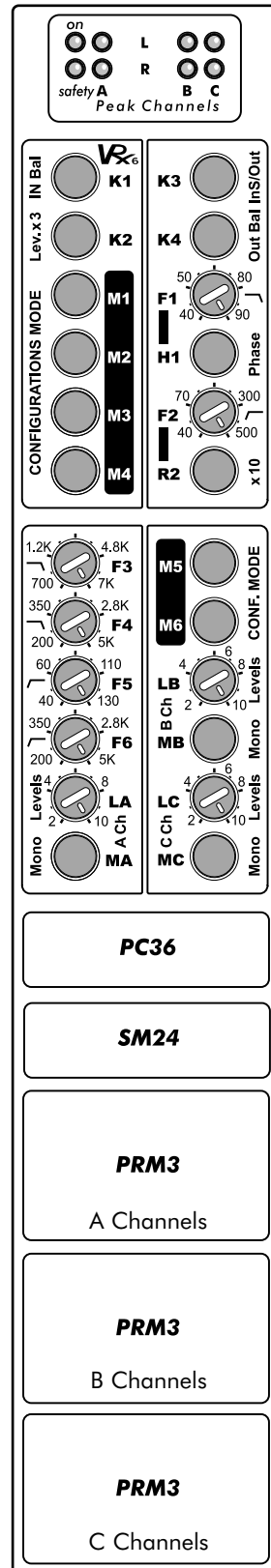

Short guide

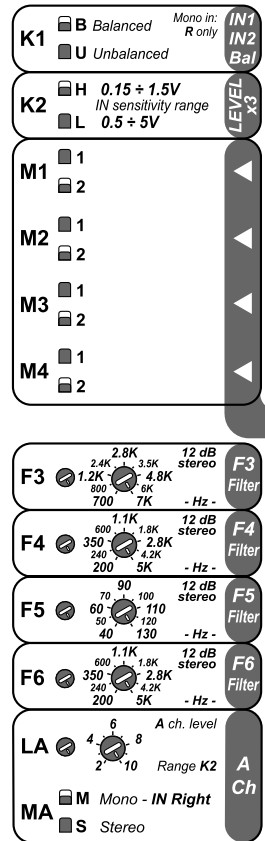

Short guide

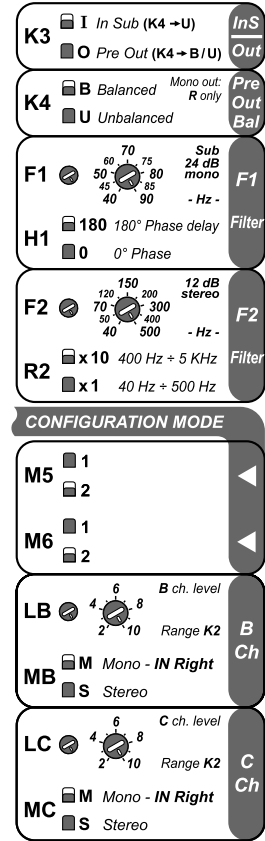

Leds

- ON - Green led**
It indicates the amplifier is on.
- SAFETY - Red led**
It indicates protection intervention: excessively high temperature or output anomalies (direct current, short circuit or dangerously low load impedance). Protection intervention stops the amplifier functioning. Switch the amplifier off; when anomaly is eliminated, switch the amplifier on again.
- PEAK CHANNELS LA - LB - RA - RB - Orange leds**
They light up when one or more VRx amplifiers are about to attain distortion threshold. They are useful to adjust inputs sensitivity.



2000 EDITION

VRx MODULAR EXTENSIONS: CONTROL EXTENSIONS

- PRM3 stereo parametric equaliser
- SM24 24dB/oct. mono subsonic filter
- PC36 360° phase controller
- DSC1 sub dynamic control
- VCRDK digital remote volume control kit (VCA1D module + VCRD adjuster)
- VCA1D VCA1D module VRx - BTX2
- MAC2 forced air modulated cooling system (2 fans with spacers to put into Terminals and Raccords, plus TFC control module)
- BTX2 stereo balancer/preamplifier

WARNING!

Apply to Audison's specialised installation centres for the installation and configuration of modular extensions described in this section

VRx Control Extensions

PRM3 One band stereo parametric equaliser with frequency, gain and bandwidth (Q) control.

Stereo parametric equaliser

Frequencies ranges: 20Hz ÷ 200Hz; 200Hz ÷ 2KHz; 2 kHz ÷ 20KHz

Gain: ± 9 dB

Q adjustment: 1 ÷ 4

Functions diagram

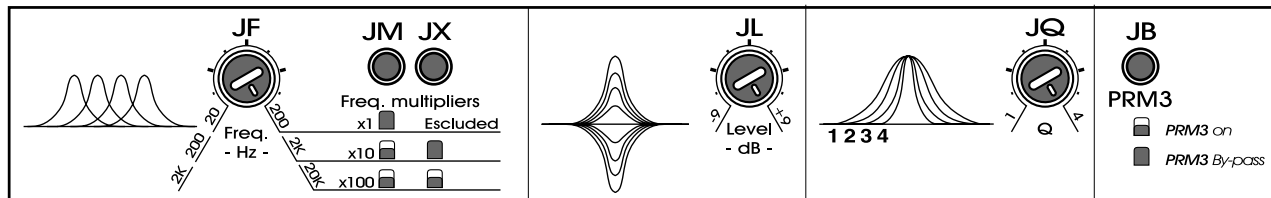

Controls panel

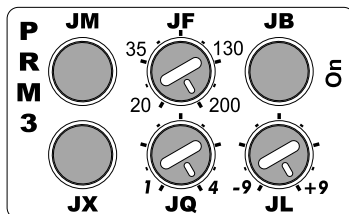

VRx1 and VRx2 amplifiers can use one PRM3 module; VRx4 amplifiers can use two; VRx6 amplifiers can use three. This allows the insertion of a parametric equalisation on each way of a multi-amplified system made with VRx amplifiers.

Warning: There is a DIP Switch to be set on **ON** into PRM3.1 modules.

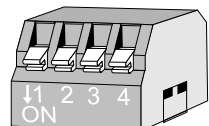

DIP Switch

Short guide

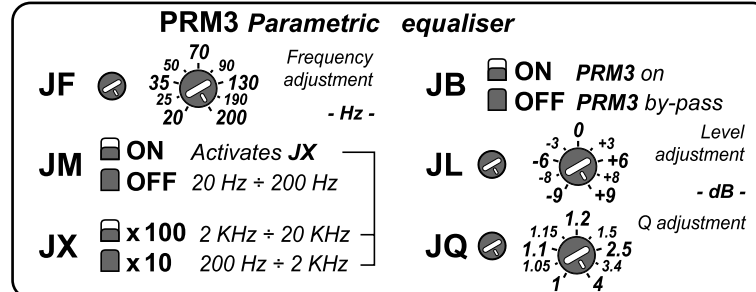

Controls description

- JF** - Frequency adjustment.
- JM** - Switch for activating frequency ranges multiplier.
- JB** - Active (ON)/BYPASS (OFF) switch.
- JX** - Frequency ranges switch.
- JL** - Level adjustment.
- JQ** - Q adjustment.

VRx Control Extensions

SM24 Monophonic subsonic filter for subwoofer.

Mono subsonic filter

24dB/oct. HI-PASS

Frequency range: 14 Hz ÷ 36 Hz

Controls panel

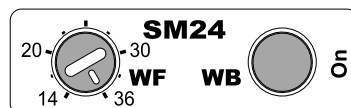

SM24 is monophonic since it was designed in order to be used with subwoofer.

It **only acts on the Right channel** of preamplified signal, therefore:

- the amplifier it drives must be configured in **mono**;
- if its output is sent to an external amplifier (possible solution with VRx4 and VRx6), **only the Right Channel** of pre output must be used.

Functions diagram

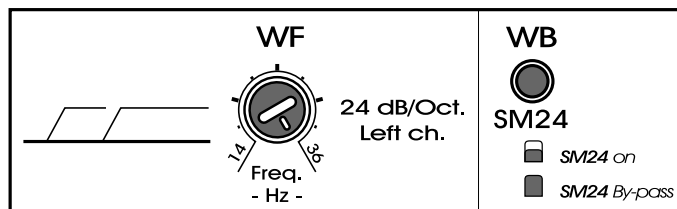

Short guide

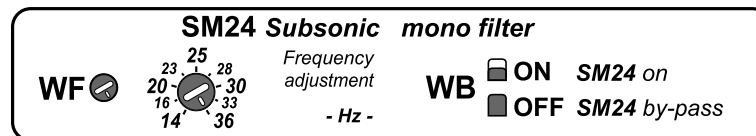

Controls description

- WF** - Frequency adjustment.
- WB** - SM24 ACTIVE (ON)/BYPASS (OFF) switch.

VRx6.420

Block diagram

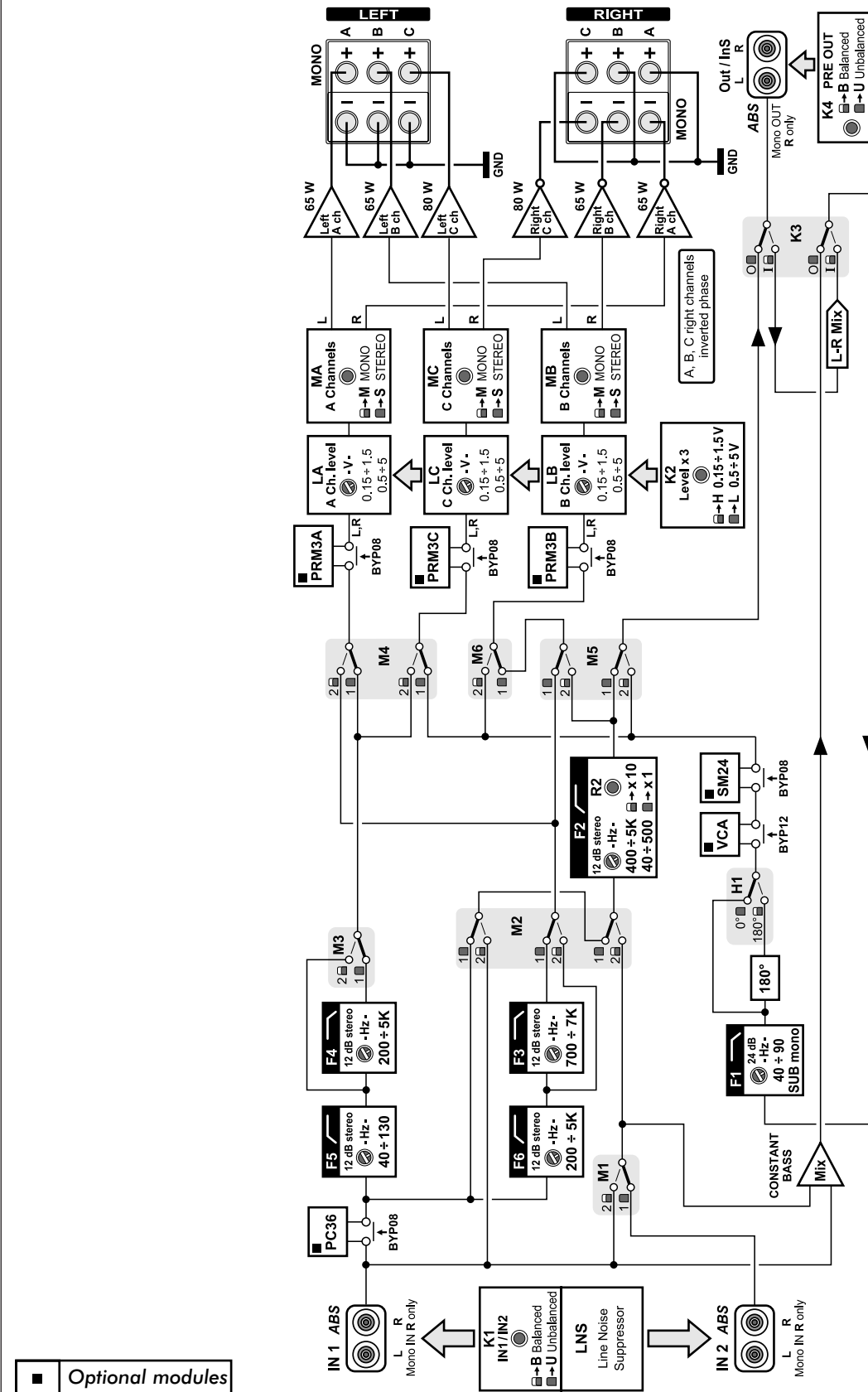

Optional modules

VRx6.420

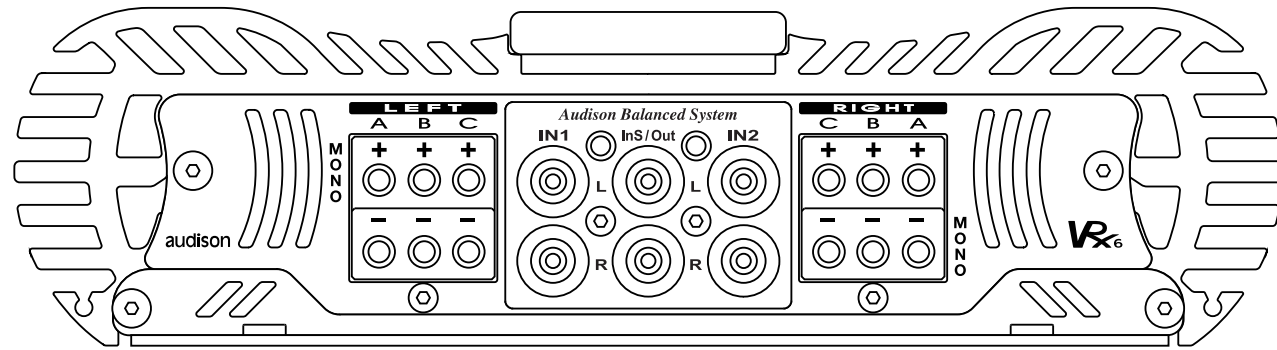

Technical features

POWER SUPPLY	11 ÷ 15 VDC
IDLING CURRENT	2.6 A
IDLING CURRENT WHEN OFF	< 0.04 mA
CONTINUOUS NOMINAL POWER Tol.: (+10%/-5%); 0.3% THD; 12 VDC	
A,B,C stereo ch. on 4 Ohms	2x65W + 2x65W + 2x80 (RMS)
CONTINUOUS POWER 6 CHANNELS Tol.: (+10%/-5%); 1% THD; 12.6 VDC	
A,B,C stereo ch. on 4 Ohms	2x75W + 2x75W + 2x85 (RMS)
CONTINUOUS POWER 6 CHANNELS Tol.: (+10%/-5%); 1% THD; 13.8 VDC	
1) A,B,C stereo ch. on 4 Ohms	2x75W + 2x75W + 2x85 (RMS)
2) A,B,C stereo ch. on 2 Ohms	2x120W + 2x120W + 2x150 (RMS)
3) A,B stereo ch. on 4 Ohms, C stereo ch. on 2 Ohms	2x75W + 2x75W + 2x165 (RMS)
4) A,B stereo ch. on 4 Ohms, C stereo ch. on 1 Ohm	2x75W + 2x75W + 2x250 (RMS)
CONTINUOUS POWER 5 CHANNELS Tol.: (+10%/-5%); 1% THD; 13.8 VDC	
5) A,B stereo ch. on 4 Ohms, C bridged ch. on 4 Ohms	2x75W + 2x75W + 1x330 (RMS)
6) A,B, stereo ch. on 4 Ohms, C bridged ch. on 2 Ohms	2x75W + 2x75W + 1x500 (RMS)
7) A,B stereo ch. on 2 Ohms, C bridged ch. on 2 Ohms	2x110W + 2x110W + 1x430 (RMS)
CONTINUOUS POWER 3 CHANNELS Tol.: (+10%/-5%); 1% THD; 13.8 VDC	
8) A,B,C bridged ch.on 4 Ohms	1x240W + 1x240W + 1x300 (RMS)
9) A,B bridged ch. on 4 Ohms, C bridged ch. on 2 Ohms	1x220W + 1x220W + 1x430 (RMS)
THD DISTORTION (1 kHz; 90% Nominal Power)	0.02%
IMD DISTORTION (90% Nominal Power)	0.04%
BANDWIDTH (-3dB; Nominal Power)	2 Hz ÷ 70 kHz
S/N RATIO (A weighed - 1 VRMS input)	100 dBA
REMOTE IN	7 ÷ 15 VDC
REMOTE OUT	12 VDC - 150 mA
INPUT SENSITIVITY (high)	0.15 ÷ 1.5 VRMS
INPUT SENSITIVITY (low)	0.50 ÷ 5.0 VRMS
INPUT IMPEDANCE	15 kOhms
LOAD IMPEDANCE (stereo) ch.A and ch.B	8 - 4 - 2 Ohms
LOAD IMPEDANCE (bridged) ch.A and ch.B	8 - 4 Ohms
LOAD IMPEDANCE (stereo) ch.C	8 - 4 - 2 - 1 Ohm
LOAD IMPEDANCE (bridged) ch.C	8 - 4 - 2 Ohms
SIZE (W x H x D) mm.	240 x 64 x 585
SIZE (W x H x D) inches	9.4 x 2.5 x 23
INTERNAL FUSE	80A

ABSORBED CURRENT AT MAXIMUM MUSICAL POWER - EXTERNAL FUSE CHOICE

13.8V - configuration 1)	.33A
13.8V - configurations 2) and 8)	.64A
13.8V - configurations 3) and 5)	.47A
13.8V - configurations 4) and 6)	.66A
13.8V - configurations 7) and 9)	.80A

Measures were realised through a test-set consisting of Rohde & Schwarz UPD audio analyser, HP 6453A power supply (200A continuous) and 14F capacitive booster made with **audison cable Superfarad** capacitors.

Please always choose a fuse of equal or slightly higher value (max 10%) than indicated.

Note:
The use of MAC2 cooling system is strongly recommended when the amplifier is employed at full power with 1 Ohm stereo or 2 Ohm bridged loads.

VRx Control Extensions

PC36 Analogue phase controller acting on the higher frequencies of a multi-amplified audio chain.

360° phase controller

Phase range: 0° ÷ 360°
Frequencies ranges: 40Hz ÷ 200Hz; 200Hz ÷ 800Hz; 800Hz ÷ 4,5kHz

Functions diagram

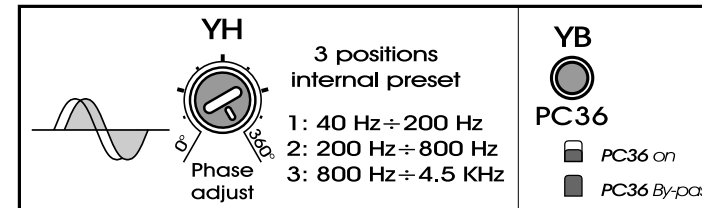

Controls panel

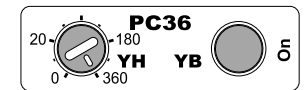

Controls description

YH - Phase adjustment.
YB - Switch: PC36 ACTIVE (**ON**)/BYPASS (**OFF**).

Short guide

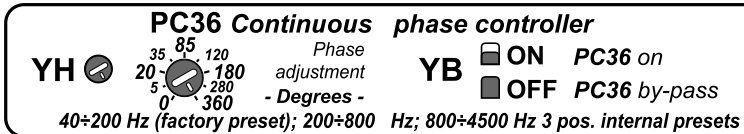

PC36 module is able to vary relative phase between two ways of a multi-amplified system. Its purpose is to make the emission of a speakers system, located in different places in car, more homogeneous. Generally speaking, PC36

module allows you to put the HI-PASS filtered way with electronic crossover in phase with regards to the one which is LO-PASS filtered in a bi-amplified system. It is possible to use two PC36 in a three way amplified system: one to align tweeters with regards to midwoofers and one to align midwoofers with regards to subwoofer.

Used into VRx4 and VRx6, PC36 allows the front system phase alignment with regards to subwoofer. Applied into VRx2 and VRx1, it permits to put all crosses of a multi-amplified system in phase if it is used together with HI-PASS sections of HL12, HL24, BH12 modules or with BAND-PASS sections of BH12.

PC36 frequency range must be set according to the cut-off frequency chosen for HI-PASS filter it must be used with.

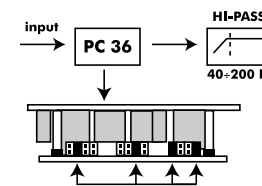

Freq. range 40Hz ÷ 200Hz

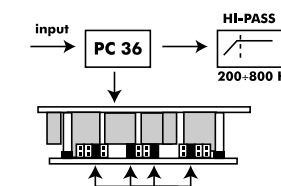

Freq. range 200Hz ÷ 800Hz

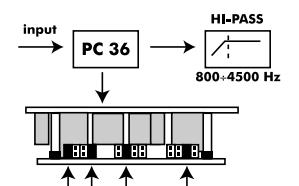

Freq. range 800Hz ÷ 4.5kHz

Pre-select frequencies ranges through jumpers according to cut-off frequencies of the HI-PASS filter it is used with. PC36 is originally set on 40 ÷ 200 Hz.

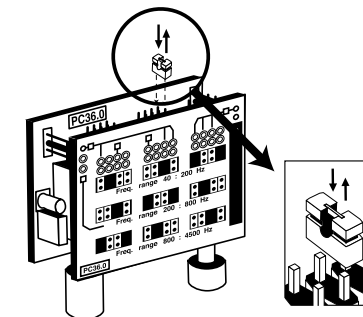

WARNING

The use of PC36 into VRx1 and VRx2 depends on the installation of HL12, BH12, HL24 multichannel extensions, since PC36 acts only on HI-PASS section.

Where PC36 acts:

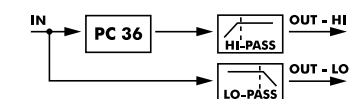

Dynamic Sub Control

Functions diagram

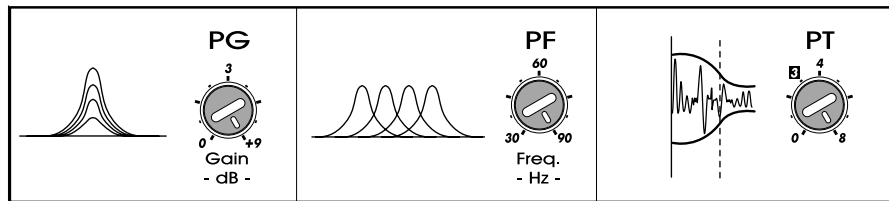

Controls panel

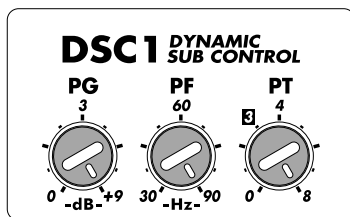

Short guide

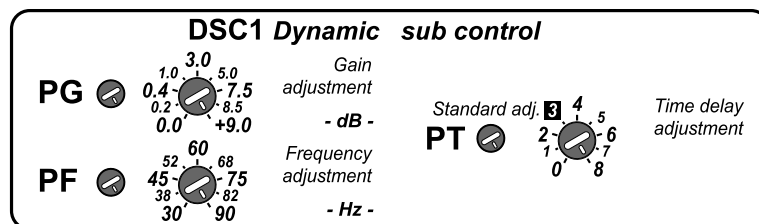

Controls description

- PG** - Gain adjustment
- PF** - Frequency adjustment
- PT** - Time delay adjustment

It is a parametric pole which permits to make up for subwoofers volumetric inadequacy by having their low frequencies gain extent and impact.

DSC1 adjusts its intervention by increasing it at low signal levels and avoiding the amplifier saturation. Its controls allow to choose frequency, intervention and gain.

VRx
audison

2000 EDITION VRx6.420



VRx Control Extensions VCRDK and VCA1D

Kit for sub remote volume control, supplied with VCA (Voltage Controlled Amplifier) with digital control.

Digital remote volume control kit

VCRDK

It consists of VCRD adjuster and of VCA1D, a high performances digital control module. It can be used to adjust the volume of sub or of every VRx amplifier in the system. If it is installed into BTX2, it permits to realise Master Volume Control. Thanks to a single VCRD adjuster connected to the main BTX2 (Master), supplied with VCA1D module (VCRDK kit), it is possible to

VCRD

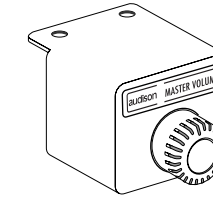

VCA1D

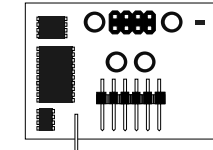

adjust the volume of other stereo ways through as many secondary BTX2 (Slave) connected in cascade and supplied with VCA1D modules. **VCA1D modules are available also individually.** Master Volume Control configuration is necessary when you want to have volume independent general adjustment in multichannel systems for Front, Rear and Sub outputs of head units supplied with them. The control microprocessor permits to store and recall a level; this function is useful to keep the reference calibration in a multi-amplified system, for instance. If the latter totally consists of VRx1 or VRx2 amplifiers, the installation of one VCRDK for every amplifier would allow the level adjustment of each way of the system. Some stickers allow VCRD customisation according to its function. It is also possible to remove its housing in order to easily mount it behind a panel, while VCRD front panel stays visible.

VRx Control Extensions

MAC2

System temperature control kit.

Forced air cooling system

It consists of a cooling group formed by a pair of fans with spacers and by a temperature control module (TFC) to put inside VRx amplifiers.

The fans group is placed inside Raccords and Terminals and adapted to several lengths through spacers. VRx amplifiers have a power supply connector dedicated to the cooling group under the power supply terminal blocks panel. Raccords and Terminals act as ducts for cooling air and have the esthetical function of covering connection cables. One terminal (TRM4, TRM6) with MAC2 kit is enough for the cooling system correct functioning. If you like to put two VRx one after the other, you have to use a suitably long

Raccord (RC08, RC10, RC12) which, if necessary, can also be supplied with MAC2, installed into the second VRx. The end of the second VRx (inputs and warm air output side) is able to accept another Terminal (TRM4, TRM6) for esthetical reasons. Raccords and Terminals are chosen according to the size of used cables and connectors, while the installation of one or more MAC2 depends on VRx amplifiers configuration.

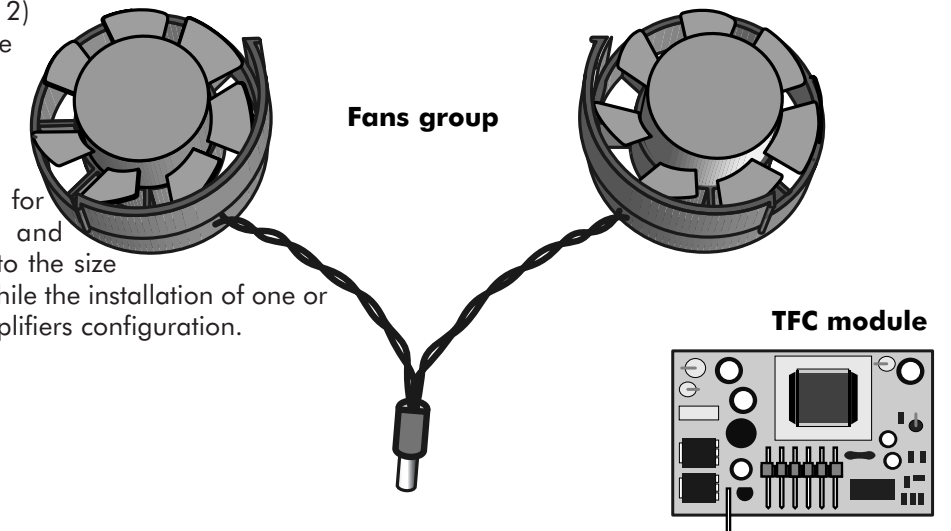

Fans group insertion inside Terminals and Raccords

INSTRUCTIONS

Put the Terminal or the Raccord onto a flat surface. (As far as Terminals are concerned, the side with grilles must be facing upwards). Remove the front plate fixed through four screws by using multispanner supplied with the devices (pict. 1 and 2). Place the fans groups onto the flat surface and push them in order to insert them inside the extension body you are using, so that the fans group support guides snap into the slots (pict. 3).

Warning!: Do not push hard onto the fans wheel while mounting the fans group.

General procedure for insertion inside Terminals

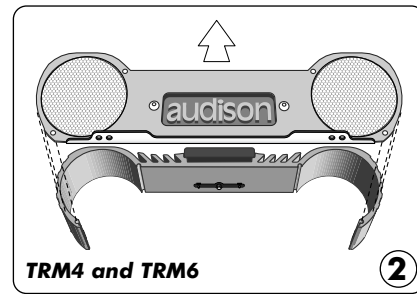
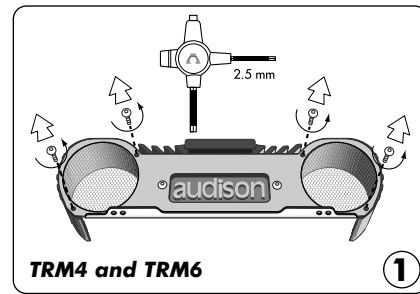

After inserting the fans, mount Terminals front plate back again (pict. 4). If parts were assembled in the right way, the fans wheels will be in the same side as the grilles of the plate itself.

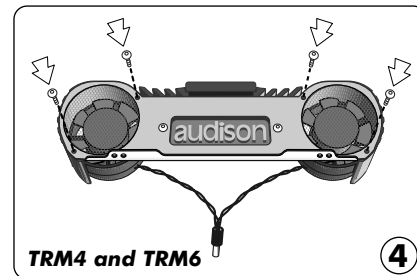
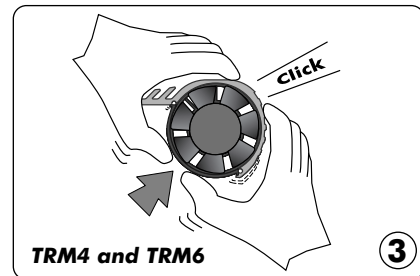

Remark for TRM4:
Do not turn the Terminal body while mounting it. Its correct direction is when the screw in the wooden strip is closer to the flat surface the terminal lies onto (pict. 2).

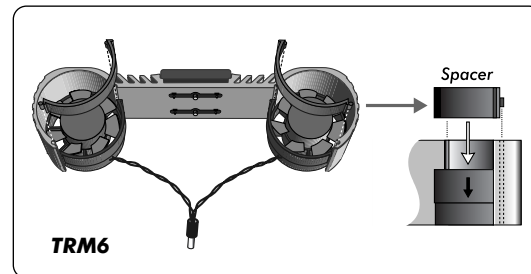

Remark for TRM6:
Insert the special spacers inside TRM6 in order to avoid air flux dispersion by making them slide onto the terminal proper slots until they touch the fans.

General procedure for insertion inside Raccords

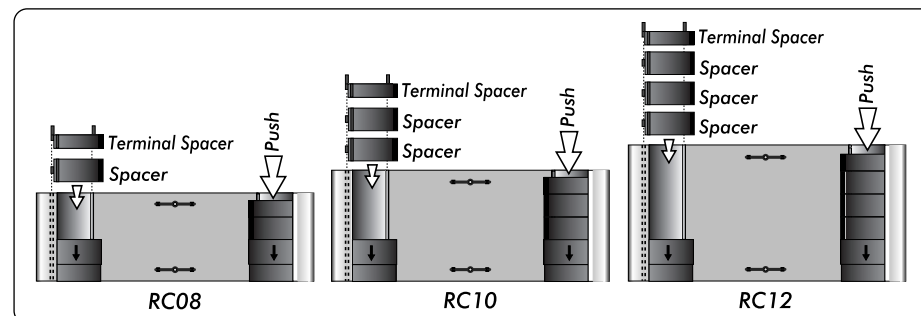

Remark for Raccords:
Insert the fans and a sufficient number of spacers into the Raccord by making them slide onto the proper slots, in order to avoid air flux dispersion. The last spacer must always be a Terminal Spacer.

VRx4.300 connections

Power supply, remote and accessories

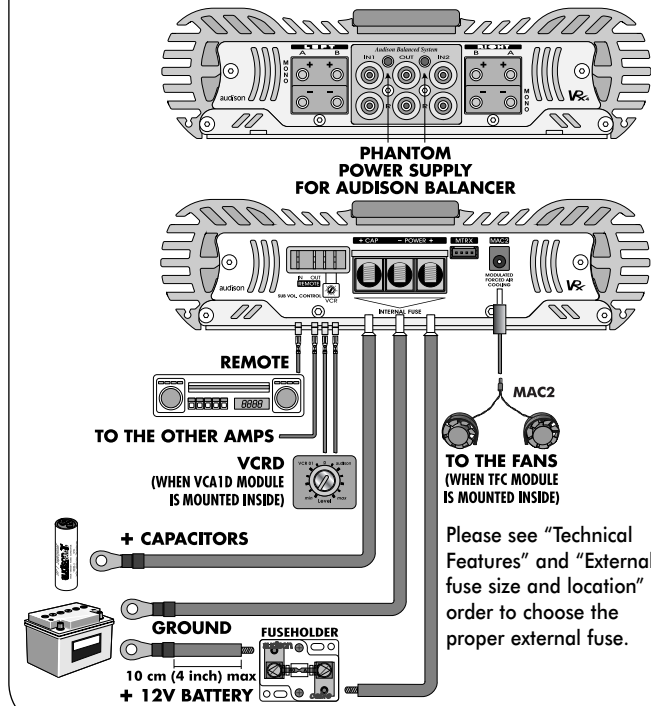

Please see "Technical Features" and "External fuse size and location" in order to choose the proper external fuse.

Inputs and outputs: stereo connection

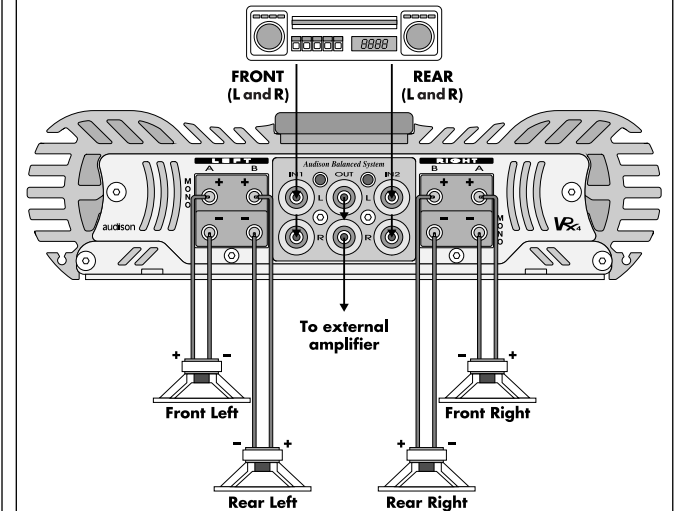

Inputs and outputs: bridge connection

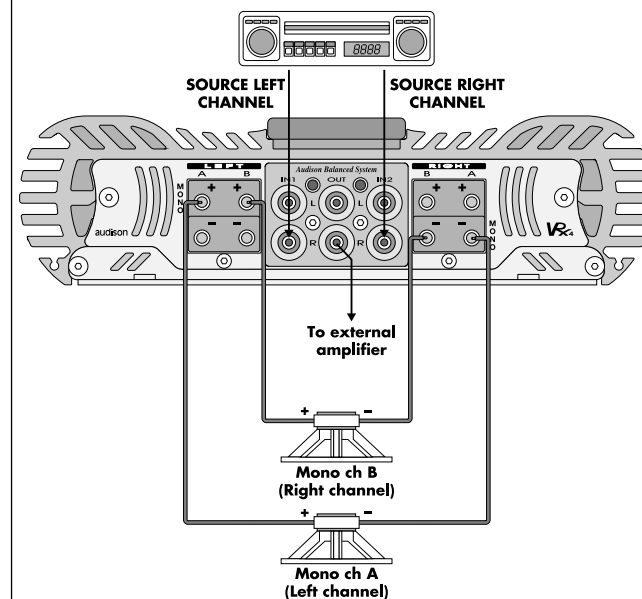

Inputs and outputs: Front + Sub

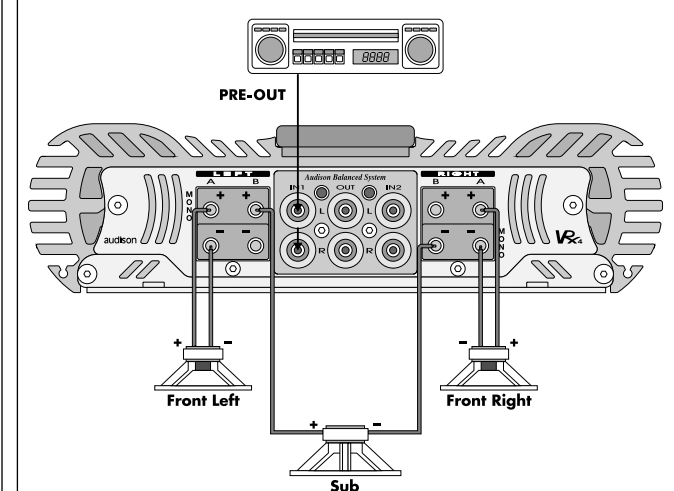

WHERE TO PUT MODULAR EXTENSIONS VRx4.300

VRx4CD-S VRx4 controls. They must not be removed.

LD1 VRx4 driver stages. They must not be removed.

CONTROL EXTENSIONS
PC36

CONTROL EXTENSIONS
SM24

CONTROL EXTENSIONS
PRM3 for A channels

CONTROL EXTENSIONS
PRM3 for B channels

CONTROL EXTENSIONS
Socket for:

VCA - VCA1D, given with VCRDK

DMRX socket for a future extension. Do not put any modules into it.

TPC VRx4 power supply controller. It must not be removed.

CONTROL EXTENSIONS
TFC

(supplied with MAC2)

	Serial modules
	Modular extensions
	BYP08 bridge: 4+4 Pins
	BYP12 bridge: 6+6 Pins

Controls under wooden strip

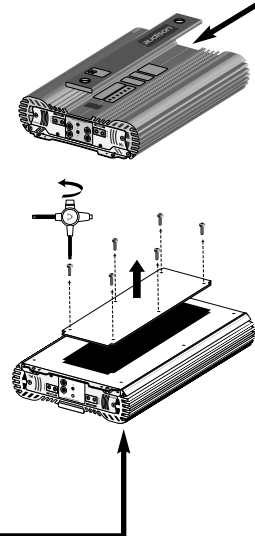
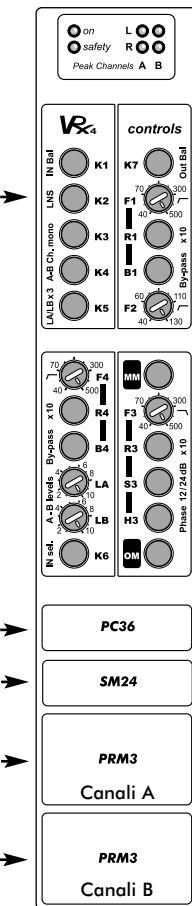

VRx Control Extensions

BTX2

Stereo balancer/preamplifier with audison ABS system.

Stereo balancer/preamplifier

FEATURES

BTX2 is a device which allows you to change a pre output of an ordinary head unit into a balanced output with **audison ABS** system. In this way it is possible to realise an ABS balanced connection between signal source and amplifier input by using **audison cable ABS** extensions.



BTX2 has got **phantom power supply**: it is therefore necessary to connect it to **audison VRx** amplifiers proper output through **PH450** cable (given with **BTX2**). **BTX2** has a three-step gain control, in order to interface with various sources. A led indicates outputs saturation (clipping). **BTX2** allows also **Remove Volume Control** function, which permits to adjust the level of a stereo or a mono line. In order to activate this function, you need to use the VCR (Remote Volume Control) kits: VCRDK.

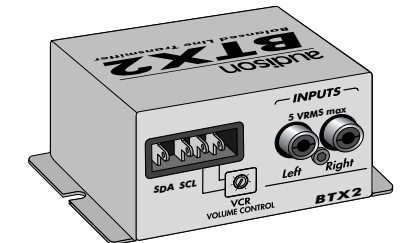

Front panel

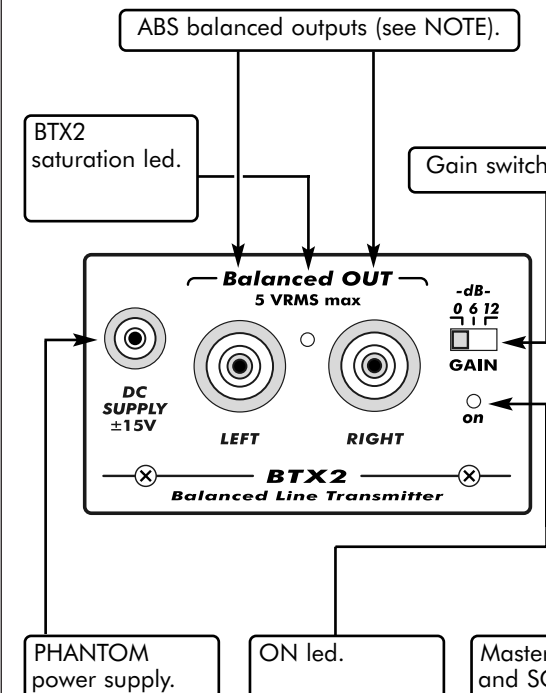

Rear panel

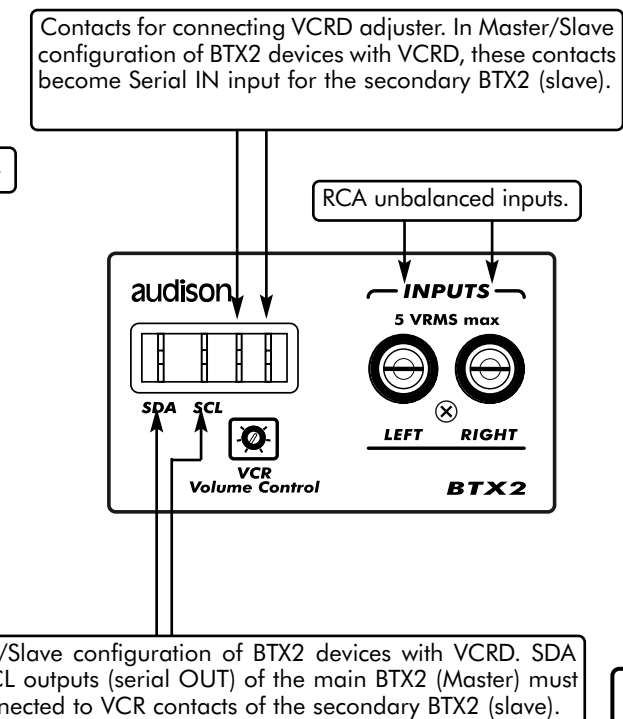

PH450

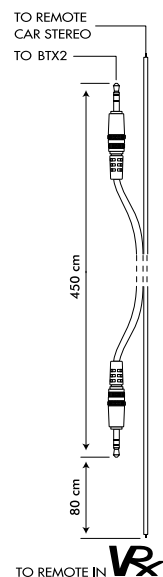

NOTE:

It is necessary to insert an ABS JACK (**audison cable**) in order to get a balanced signal. It is possible to have an unbalanced signal by inserting a standard PIN RCA into ABS sockets. In this case, output voltage value decreases; it can be increased again through GAIN switch.

PH150(150cm) and **PH650**(650cm) are available in **audison cable** line, besides **PH450**(450cm)

VRx4.300

24dB/oct. Mono SUB filter slope configurations

K6 = **2 INPUTS:** **IN1** Front L and R inputs, **IN2** Rear L and R inputs; non fading sub.*
K6 = **1 INPUT:** **IN** L and R inputs, **IN2** not used; sub mix R+L.

S3 (12-24dB/oct. SUB filter slope switch) = **K4** (MONO/STEREO switch of B channels) =
K3 (MONO/STEREO switch of A channels) = **R3** (F3 x 1/x10 LO-PASS frequency switch) =

Power Outputs	STEREO	MONO	STEREO line outputs	Switch config.	
	loudspeakers outputs	loudspeakers outputs		MM	OM
N°	Ch "A" amps.	Ch "B" amps.	PREAMPLIFIED	MM	OM
3	HI FRONT Filter Bypass 40 Hz ÷ 5 kHz Power: 75 W + 75 W	SUB MONO 24 dB 40 Hz ÷ 500 Hz Power: 250W	HI REAR Filter Bypass 40 Hz ÷ 5 kHz	<input type="checkbox"/>	<input type="checkbox"/>

K6 = **2 INPUT:** **IN1** input Front L e R, **IN2** input Rear L e R; non fading sub.*
K6 = **1 INPUT:** **IN1** input L e R, **IN2** not used; sub mix R+L.

S3 (12-24dB/oct. SUB filter slope switch) = **K4** (MONO/STEREO switch of B channels) =
K3 (MONO/STEREO switch of A channels) = **R3** (F3 x 1/x10 LO-PASS frequency switch) =

Power Outputs	STEREO loudspeakers outputs		Signal out on RIGHT ch. (LEFT not used)	Switch config.	
	Ch "A" amps.	Ch "B" amps.	PREAMPLIFIED	MM	OM
4	HI FRONT Filter Bypass 40 Hz ÷ 5 kHz Power: 75 W + 75 W	HI REAR Filter Bypass 40 Hz ÷ 5 kHz Power: 75 W + 75 W	SUB MONO 24 dB 40 Hz ÷ 500 Hz	<input type="checkbox"/>	<input type="checkbox"/>

K6 = **INPUTS:** use **IN1 (R)** for Left ch, use **IN2 (R)** for Right ch.

S3 (12-24dB/oct. SUB filter slope switch) = **K4** (MONO/STEREO switch of B channels) =
K3 (MONO/STEREO switch of A channels) =

Power Outputs	MONO loudspeakers outputs		MONO line outputs (LEFT not used)	Switch config.	
	Ch "A" amps. Left section	Ch "B" amps. Right section	PREAMPLIFIED	MM	OM
2	HI-PASS Filter Bypass 40 Hz ÷ 5 kHz Power: 250 W	HI-PASS Filter Bypass 40 Hz ÷ 5 kHz Power: 250 W	SUB MONO 24 dB (RIGHT) 40 Hz ÷ 500 Hz	<input type="checkbox"/>	<input type="checkbox"/>

* with active Constant Bass

VRx4.300 12dB/oct. SUB filter slope configurations

* **Warning:** Using B channels in Mono (K4 =) with 12dB/Oct. filter, signal for sub depends on Right input. If you move Balance onto the Left channel in this condition, sub will not play. It is therefore necessary to set B channels in stereo (K4 =) in order to obtain the sum between Left and Right.

K6 = 2 INPUTS: IN1 Front L and R inputs, IN2 Rear L and R inputs; non fading sub.
K6 = 1 INPUT: IN1 L and R inputs, IN2 not used.

S3 (12-24dB/oct. SUB filter slope switch) = **K4** (MONO/STEREO switch of B channels) =
K3 (MONO/STEREO switch of A channels) =

Power Outputs	STEREO loudspeakers outputs		STEREO line outputs	Switch config.		
	N°	Ch "A" amps.	Ch "B" amps.	PREAMPLIFIED	MM	OM
4	MID-HI FRONT B1 Filter Bypass 40 Hz ÷ 5 kHz Power: 75 W + 75 W	WOOFER FRONT F2 F3 40 Hz ÷ 130 Hz 40 Hz ÷ 5 kHz Power: 75 W + 75 W	HI REAR B4 Filter Bypass 40 Hz ÷ 5 kHz	<input type="checkbox"/>	<input type="checkbox"/>	<input type="checkbox"/>
4	MID-HI FRONT B1 Filter Bypass 40 Hz ÷ 5 kHz Power: 75 W + 75 W	HI-REAR B4 Filter Bypass 40 Hz ÷ 5 kHz Power: 75 W + 75 W	WOOFER FRONT F2 F3 40 Hz ÷ 130 Hz 40 Hz ÷ 5 kHz	<input type="checkbox"/>	<input type="checkbox"/>	<input type="checkbox"/>
4	HI FRONT B1 Filter Bypass 40 Hz ÷ 5 kHz Power: 75 W + 75 W	HI REAR B4 Filter Bypass 40 Hz ÷ 5 kHz Power: 75 W + 75 W	SUB F3 40 Hz ÷ 5 00 Hz	<input type="checkbox"/>	<input type="checkbox"/>	<input type="checkbox"/>
3/4	HI FRONT B1 Filter Bypass 40 Hz ÷ 5 kHz Power: 75 W + 75 W	SUB F3 40 Hz ÷ 5 00 Hz Power: 250W (Mono) 75W+75W (Stereo)	HI REAR B4 Filter Bypass 40 Hz ÷ 5 kHz	<input type="checkbox"/>	<input type="checkbox"/>	<input type="checkbox"/>

K6 = INPUTS: use IN1 (R) for Left ch, use IN2 (R) for Right ch.
S3 (12-24dB/oct. SUB filter slope switch) = **K4** (MONO/STEREO switch of B channels) =
K3 (MONO/STEREO switch of A channels) =

Power Outputs	MONO loudspeakers outputs		MONO line outputs	Switch config.		
	N°	Ch "A" amps. Left section	Ch "B" amps. Right section	PREAMPLIFIED	MM	OM
2	HI-PASS B1 Filter Bypass 40 Hz ÷ 5 kHz Power: 250 W	HI-PASS B4 Filter Bypass 40 Hz ÷ 5 kHz Power: 250 W	SUB F3 40 Hz ÷ 500 Hz	<input type="checkbox"/>	<input type="checkbox"/>	<input type="checkbox"/>

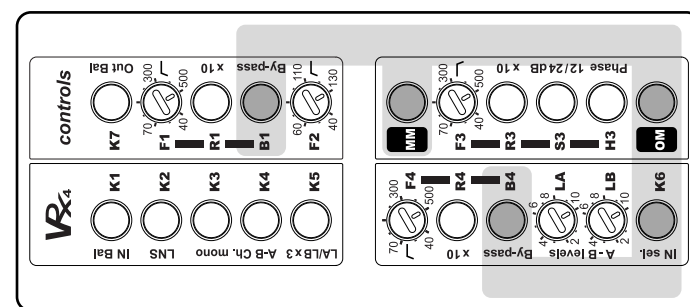

- = Pushed switch
- = Released switch
- B1 = F1 filter BYPASS
- B4 = F4 filter BYPASS
- F1 = HI-PASS filter
- F2 = HI-PASS filter of woofer BAND-PASS (MM =), it does not work if MM =
- F3 = LO-PASS filter of woofer BAND-PASS (MM =) or subwoofer LO-PASS filter (MM =)
- F4 = HI-PASS filter



2000 EDITION

VRx MODULAR EXTENSIONS: MULTICHANNEL EXTENSIONS

(only for models: VRx1.500, VRx2.150, VRXx2.250 and VRx2.400)

- HL12 12 dB HI/LO-PASS crossover
- BH12 12 dB BAND/HI-PASS crossover
- LM24 24 dB LO-PASS MONO crossover
- HL24 12/24 dB HI/LO-PASS crossover
- BSA1 stereo balanced pre out repeater

WARNING!

Apply to Audison's specialised installation centres for the installation and configuration of modular extensions described in this section

VRx1 - VRx2 Multichannel Extensions HL12

Crossover module for VRx1 and VRx2, with non independent HI/LO-PASS crossover frequency.

Crossover

12dB/oct. HI-PASS/LO-PASS

Frequencies ranges: 40 Hz ÷ 500 Hz; 400 Hz ÷ 5 kHz

Block diagram

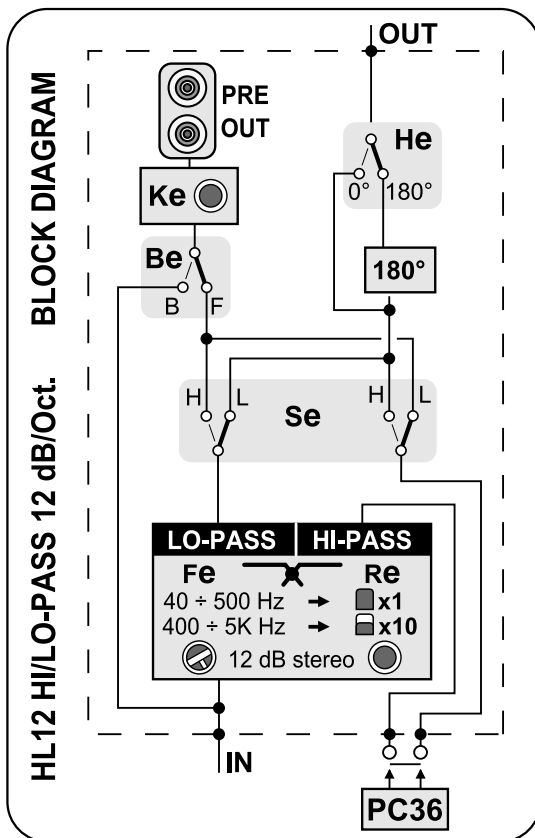

Controls panel

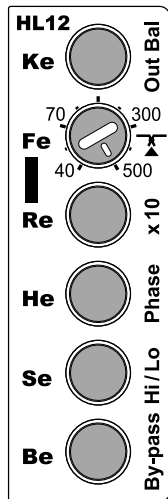

Short guide

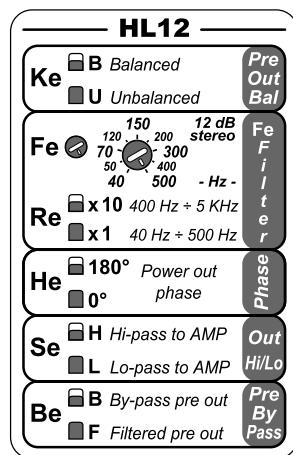

Sticker to put onto VRx1 and VRx2 short guide together with Block Diagram one

Controls description

- Ke** - BALANCED (B)/UNBALANCED (U) switch for PRE OUT output.
- Fe** - 12dB/oct. HI/LO-PASS crossover frequency adjustment.
- Re** - Fe x 10 (x10)/x1 (x1) frequency switch.
- He** - 0° (0°)/180° (180°) phase shifting switch for amplifier output.
- Se** - HI-PASS (H)/LO-PASS (L) switch for PRE OUT output.
- Be** - BYPASS (B)/FILTERED (F) switch for PRE OUT output.

Module description

Filter slope: 12dB/oct. Continuous adjustment through 2 steps: 40÷500Hz; 400÷5000Hz. HL12 adds one ABS PRE output to the amplifier it is installed into.

Features

Installed into VRx1 or VRx2, HL12 permits to drive stereo/mono SUB section with 12dB cut. HI-PASS output permits to drive an amplifier without crossover (non independent crossover frequency). The BYPASS output of the first amplifier allows the independent control of HI-PASS frequencies by adding a VRx2 supplied with another HL12. In combination with another VRx2, the use of HI-PASS output also allows the creation of BAND-PASS sections.

Uses

HL12 is a very versatile and polyvalent module. It can be used in the simplest bi-amplified systems, in REAR section or in high performances multi-amplified systems. According to VRx philosophy, it is the "factotum" you have to keep at hand, because it is always possible to filter a system through it. It is the ideal partner for VRx2 and LM24.

Possible configurations

OUT	PRE-OUT	Se HI/LO-PASS	Be BYPASS
		<input type="checkbox"/>	<input type="checkbox"/>
	<input type="checkbox"/>	<input type="checkbox"/>	<input type="checkbox"/>
		<input type="checkbox"/>	<input type="checkbox"/>
	<input type="checkbox"/>	<input type="checkbox"/>	<input type="checkbox"/>

VRx4.300

Short guide under wooden strip

It shows internal crossover, outputs configurations and controls meaning

See owner's manual before any adjustment

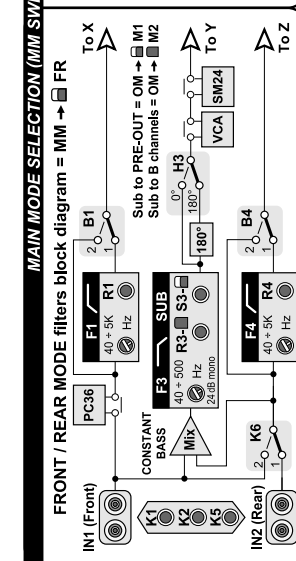
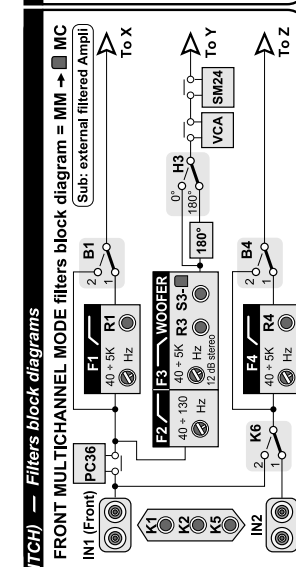
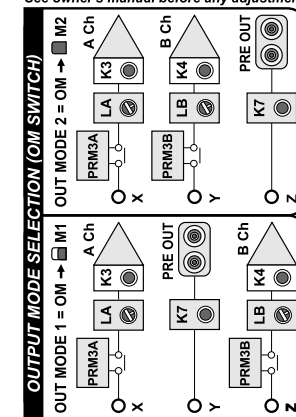

10125721

VRx4 controls

K1 B Balanced Mono in: IN1 IN2 Bal U Unbalanced

K2 OFF Line Noise Suppressor ON

K3 M Mono - IN1 Right S Stereo

K4 M Mono - IN2 Right S Stereo

K5 H 0.15 ÷ 1.5V IN sensitivity range L 0.5 ÷ 5V

K7 B Balanced Mono out: Pre Out Bal U Unbalanced

F1 150 12 dB stereo 70 200 300 12 dB stereo 50 400 500 - Hz - 40 500 - Hz -

R1 x 10 400 Hz ÷ 5 KHz x 1 40 Hz ÷ 500 Hz

B1 2 Filter by-pass 1 Filter active

F2 90 12 dB stereo 70 200 300 12 dB stereo 50 400 500 - Hz - 40 500 - Hz -

Main mode selection - MM

F4 150 12 dB stereo 70 200 300 12 dB stereo 50 400 500 - Hz - 40 500 - Hz -

R4 x 10 400 Hz ÷ 5 KHz x 1 40 Hz ÷ 500 Hz

B4 2 Filter by-pass 1 Filter active

LA 6 A ch. level 2 10 Range K5

LB 6 B ch. level 2 10 Range K5

K6 2 IN2 input not used 1 IN1 Front; IN2 Rear

MM FR Front - Rear mode MC Multichannel mode

F3 150 12 dB stereo 70 200 300 12 dB stereo 50 400 500 - Hz - 40 500 - Hz -

R3 x 10 400 Hz ÷ 5 KHz x 1 40 Hz ÷ 500 Hz

S3 24 24 dB/Oct. mono 12 12 dB/Oct. stereo Use S3=24 only with R3=x1 and K4=M

H3 180 180° Phase delay 0 0° Phase

OM M1 Output mode 1 M2 Output mode 2

Out mode selection - OM

PC36 Continuous phase controller

YH 85 Phase adjustment ON PC36 on OFF PC36 by-pass

40÷200 Hz (factory preset); 200÷800 Hz; 800÷4500 Hz 3 pos. internal presets

SM24 Subsonic mono filter

WF 23 25 Frequency adjustment ON SM24 on OFF SM24 by-pass

SM24 output: bridged amp (OM on M2) or PRE OUT Right Channel (OM on M1)

PRM3 A - PRM3 B Parametric equaliser

JF 70 Frequency adjustment ON PRM3 on OFF PRM3 by-pass

JM ON Activates JX OFF 20 Hz ÷ 200 Hz

JX x 100 2 KHz ÷ 20 KHz x 10 200 Hz ÷ 2 KHz

JB ON PRM3 on OFF PRM3 by-pass

JL -3 0 +3 Level adjustment -6 -8 +8 -dB - -9 +9

JQ 1.15 1.2 1.5 Q adjustment 1.05 1.1 2.5 1 4

VRx4.300

Controls and functions

Controls description

- K1 - Bal/Unbal inputs** switch.
- K2 - LNS** circuit **ON/OFF** switch for line noise suppression.
- K3, K4 - Mono / Stereo** switch for A and B amplifiers pairs respectively.
- K5** - It selects **sensitivity range** of all inputs.
- LA, LB** - Input **sensitivities adjustment** of A and B amplifiers pairs respectively.
- K6 - 1/2 inputs pairs** switch.
- K7 - Bal/Unbal** switch for PRE output. It is possible to have a balanced output signal even with an unbalanced input one.
- F2** - Filter used only in **Multichannel** mode in order to have a BAND-PASS.
- F3** - LO-PASS filter which can be set at **24dB/oct.** slope **ONLY in mono configuration**, 40-500 Hz range, for subwoofer (**F/R** mode).
- MM and OM** - They select **internal crossover functioning modes**. Please see VRx block diagram and uses in order to understand how they act.

Warning: When SM24 is used for B Channels, the latter will have to be configured in mono. **K4** must be put onto **Mono**.

Note: In case of installations with more amplifiers connected in cascade, we recommend to put **K2** onto **ON** in the device which receives the signal from the head unit, leaving it onto **OFF** in the others. If disturbance persists, please try to activate **LNS** anti-noise circuit also in the other amplifiers.

Controls under wooden strip



Short guide

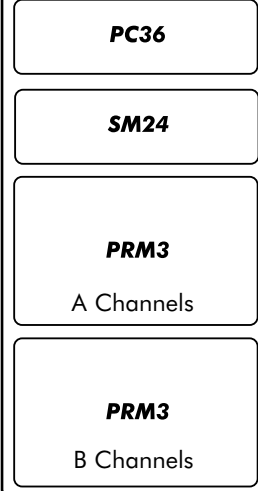
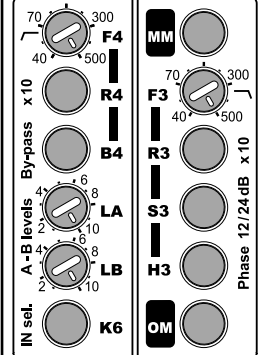
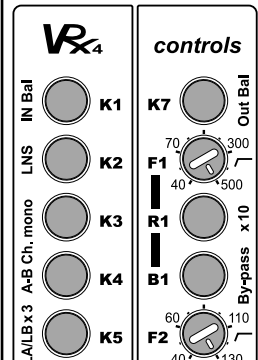
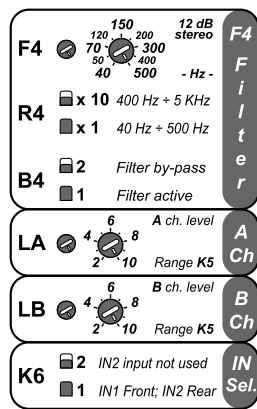
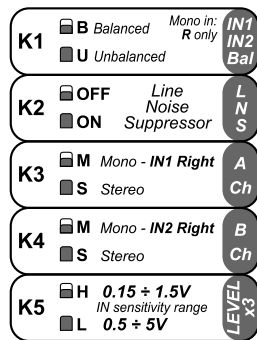

Short guide

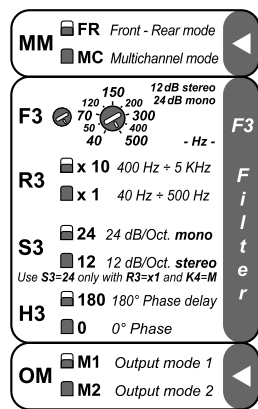
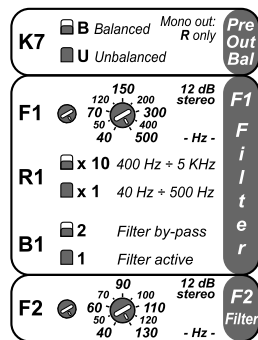

Leds

- ON - Green led** It indicates the amplifier is on.
- SAFETY - Red led** It indicates protection intervention: excessively high temperature or output anomalies (direct current, short circuit or dangerously low load impedance). Protection intervention stops the amplifier functioning. Switch the amplifier off; when anomaly is eliminated, switch the amplifier on again.
- PEAK LA - LB - RA - RB - Orange leds** They are on when one or more VRx amplifiers are about to reach distortion threshold. They are useful to adjust inputs sensitivity.

VRx2 Multichannel Extensions BH12

Crossover module for VRx2 with BAND-PASS filter with independent adjustments and non independent HI-PASS crossover frequency.

Crossover

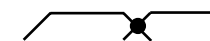

12dB/oct. BAND-PASS/HI-PASS
F1 frequencies ranges: 40 Hz ÷ 280 Hz; 280 Hz ÷ 2 kHz
F2 frequency range: 150 Hz ÷ 5 kHz

Block diagram

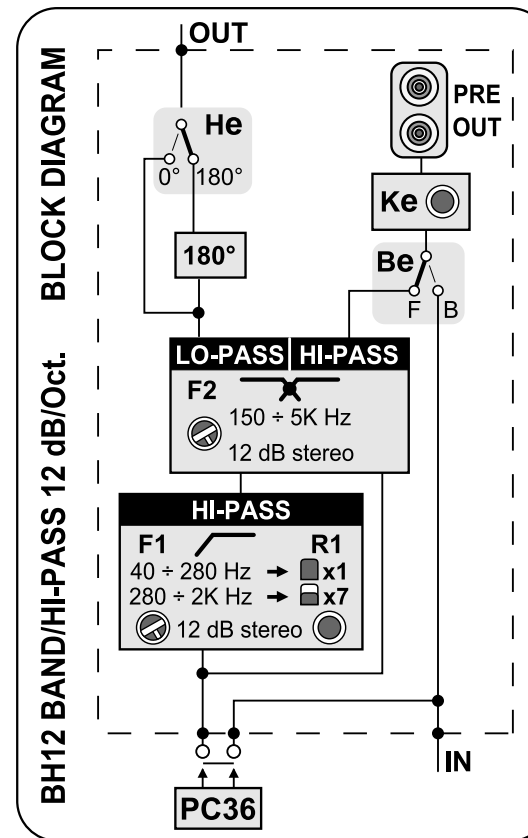

Controls panel

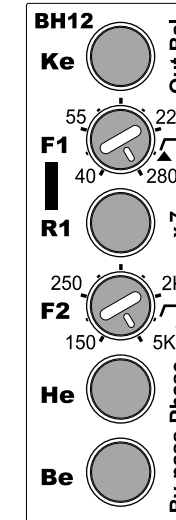

Short guide

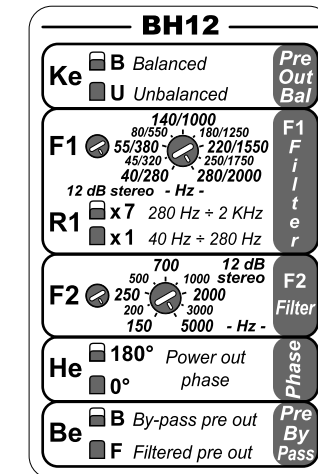

Controls description

- Ke** - BALANCED (**B**)/UNBALANCED (**U**) switch for PRE OUT output.
- F1** - 12dB/oct. BAND-PASS lower frequency adjustment.
- R1** - F1 x 7 (**x7**)/x1 (**x1**) frequency switch.
- F2** - 12dB/oct. BAND-PASS higher frequency and 12dB/oct. HI-PASS lower frequency adjustment.
- He** - 0° (**0°**)/180° (**180°**) phase shifting switch for amplifier output.
- Be** - BYPASS (**B**)/HI-PASS (**F**) switch for PRE OUT output.

Module description

BAND/HI-PASS section (Lower frequency): 12dB/oct. filter slope. Variable frequency between 40Hz and 2kHz, through 2 steps: 40Hz÷280Hz; 280Hz÷2kHz. Continuous adjustment.
 BAND/LO-PASS (Higher frequency) and HI-PASS section: 12dB/oct. filter slope. Variable frequency between 150 and 5000Hz. Continuous adjustment. BH12 adds one ABS PRE output to the amplifier it is installed into.

Features

It allows the extension to higher frequency ranges in multi-amplified systems. Together with HL12, it permits the frequencies total independent control.

Uses

BH12 is especially designed for multi-amplification. Its high internal complexity makes its use simple and evident. It is VRx2 partner and it is ideal for HL12 and LM24.

Possible configurations

OUT	PRE OUT	Be BYPASS

VRx1 - VRx2 Multichannel Extensions LM24

Crossover module for VRx1 and VRx2 with LO-PASS MONO cut and L/R channels mixing.

Crossover

24dB/oct. mono LO-PASS
Frequency range: 40 Hz ÷ 90 Hz

Block diagram

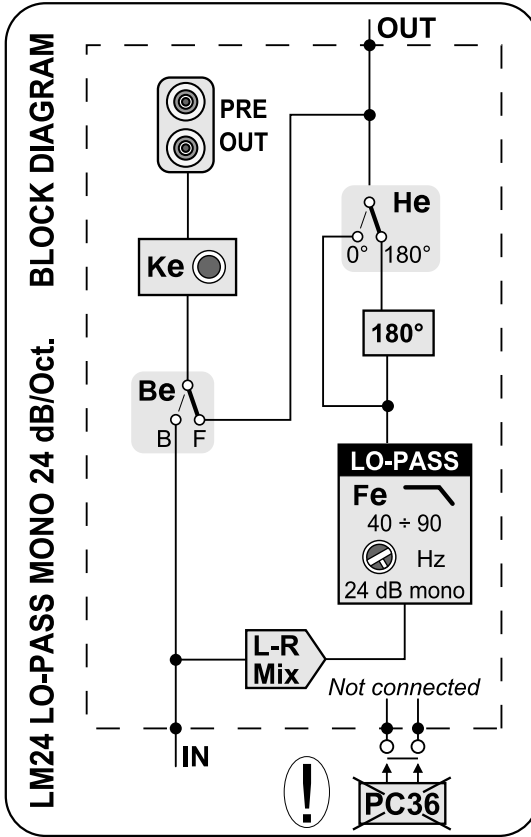

Controls panel

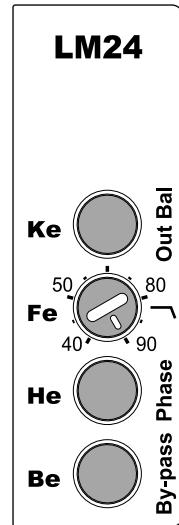

Short guide

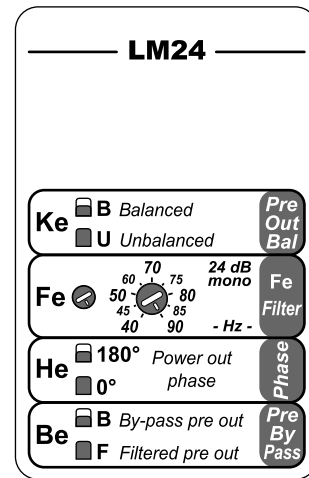

Sticker to put onto VRx1 and VRx2 short guide together with Block Diagram one.

Controls description

- Ke** - BALANCED (B)/UNBALANCED (U) switch for PRE OUT output.
- Fe** - 24dB/oct. LO-PASS filter adjustment.
- He** - 0° (0°)/180° (180°) phase shifting switch for amplifier output.
- Be** - BYPASS (B)/LO-PASS (F) switch for PRE OUT output.

Module description

24dB/oct. filter slope. Variable frequency between 40Hz and 90Hz. Continuous adjustment. LM24 adds one ABS PRE output to the amplifier it is installed into.

Features

Installed onto VRx1 or VRx2, it permits to drive SUB section in MONO with cut at 24dB. BYPASS output allows the addition of another VRx2 filtered with HL12 or BH12 in order to have independent HI-PASS control. LO-PASS output permits to add another amplifier to boost SUB section; naturally, in this case, a full range signal coming from a VRx2 with HL12 must be sent to the input of the amplifier where LM24 is installed, and VRx2 and HL12 will handle HI-PASS section.

Note: LM24 includes only a LO-PASS section and, thus, it does not permit to use PC36 since the latter must be employed together with a HI-PASS section in order to function in the right way (see part B, p. 5).

Uses

LM24 is especially designed for SUB section and has the advantages of cut at 24dB. It is indispensable both in bi-amplified systems and multi-amplified ones. It is the ideal partner of VRx1 and HL12.

Possible configurations

OUT	PRE OUT	Be BYPASS
		<input type="checkbox"/>
		<input type="checkbox"/>

VRx4.300

Block diagram

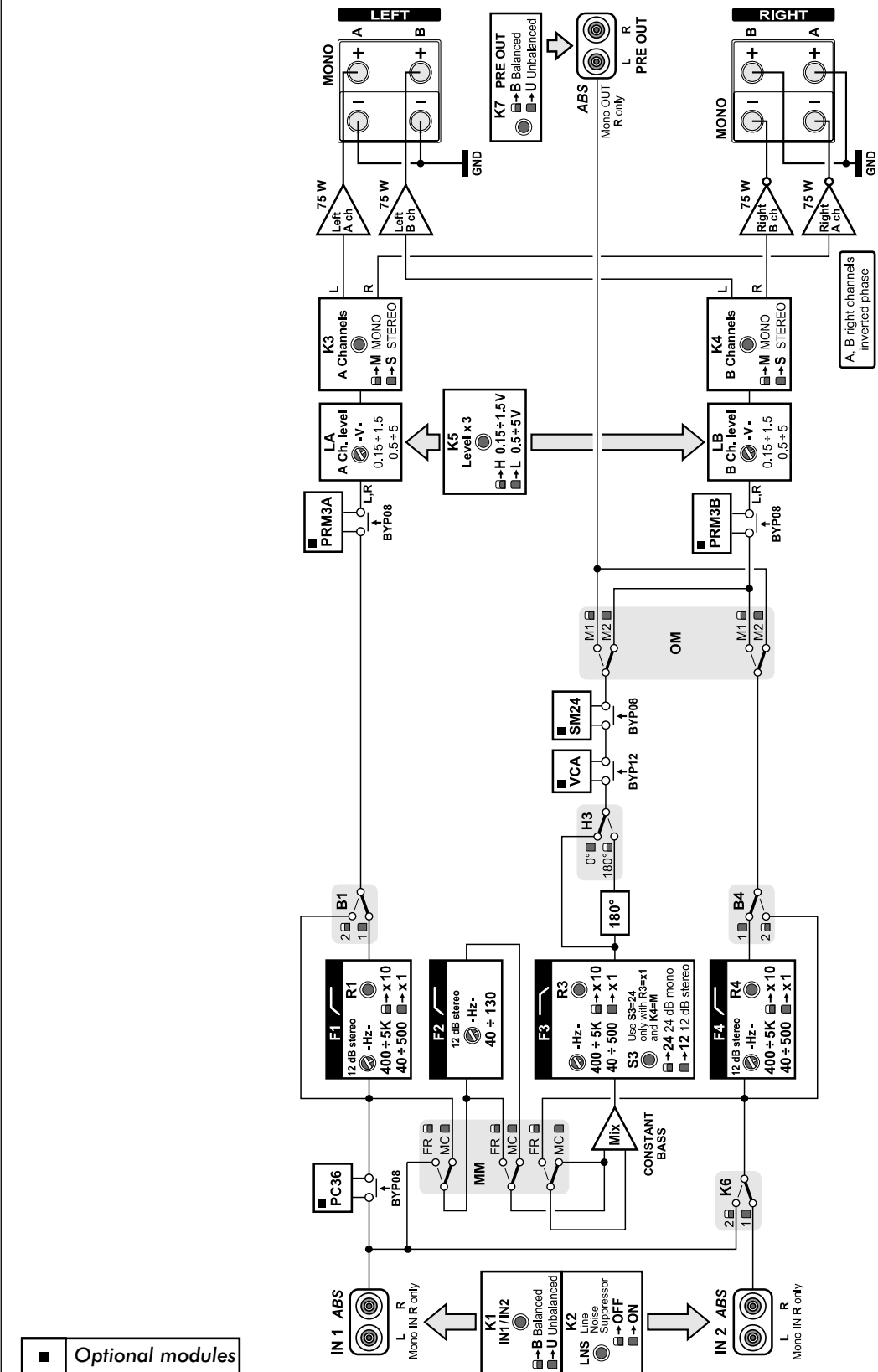

Optional modules

VRx4.300

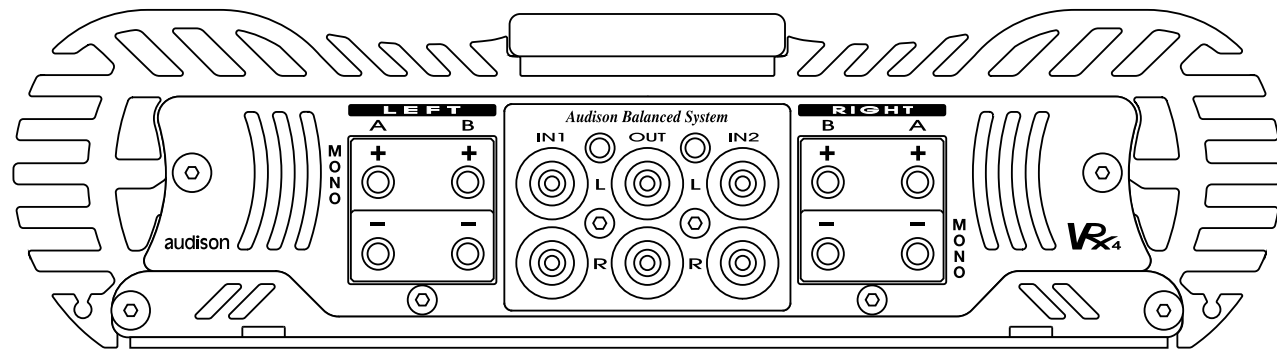

Technical features

POWER SUPPLY	11 ÷ 15 VDC
IDLING CURRENT	2.2 A
IDLING CURRENT WHEN OFF	< 0.04 mA
CONTINUOUS NOMINAL POWER Tol.: (+10%/-5%); 0.3% THD; 12 VDC	
4 ch on 4 Ohms	75 W x 4 (RMS)
CONTINUOUS POWER Tol.: (+10%/-5%); 1% THD; 12.6 VDC	
4 ch on 4 Ohms	110 W x 4 (RMS)
CONTINUOUS POWER Tol.: (+10%/-5%); 1% THD; 13.8 VDC	
4 ch on 4 Ohms	110 W x 4 (RMS)
4 ch on 2 Ohms	175 W x 4 (RMS)
4 ch on 1 Ohm	220 W x 4 (RMS)
2 ch bridged on 4 Ohms + 2 ch bridged on 4 Ohms	350 W + 350 W (RMS)
2 ch bridged on 2 Ohms + 2 ch bridged on 2 Ohms	440 W + 440 W (RMS)
2 ch on 4 Ohms + 2 ch bridged on 4 Ohms	102 W x 2 + 380 W (RMS)
2 ch on 4 Ohms + 2 ch bridged on 2 Ohms	90 W x 2 + 530 W (RMS)
THD DISTORTION (1 kHz; 90% Nominal Power)	0.02 %
IMD DISTORTION (90% Nominal Power)	0.04 %
BANDWIDTH (-3dB; Nominal Power)	2 Hz ÷ 70 kHz
S/N RATIO (A weighed - 1 VRMS input)	100 dBA
REMOTE IN	7 - 15 VDC
REMOTE OUT	12 VDC ÷ 150 mA
INPUT SENSITIVITY (high)	0.15 ÷ 1.5 VRMS
INPUT SENSITIVITY (low)	0.50 ÷ 5.0 VRMS
INPUT IMPEDANCE	15 kOhms
LOAD IMPEDANCE (stereo)	8 - 4 - 2 - 1 Ohm
LOAD IMPEDANCE (bridged)	8 - 4 - 2 Ohms
SIZE (W x H x D) mm	240 x 64 x 499
SIZE (W x H x D) inches	9.4 x 2.5 x 19.6
INTERNAL FUSE	70A

ABSORBED CURRENT AT MAXIMUM MUSICAL POWER - EXTERNAL FUSE CHOICE

13.8V - 4 ch. x 4 Ohms or 2 bridged ch. x 8 Ohms + 2 bridged ch. x 8 Ohms	27 A
13.8V - 4 ch. x 2 Ohms or 2 bridged ch. x 4 Ohms + 2 bridged ch. x 4 Ohms	47 A
13.8V - 4 ch. x 1 Ohm or 2 bridged ch. x 2 Ohms + 2 bridged ch. x 2 Ohms	70 A
13.8V - 2 ch. x 4 Ohms + 2 bridged ch. x 4 Ohms	38 A
13.8V - 2 ch. x 4 Ohms + 2 bridged ch. x 2 Ohms	52 A

Measures were realised through a test-set consisting of Rohde & Schwarz UPD audio analyser, HP 6453A power supply (200A continuous) and 14F capacitive booster made with **audison cable Superfarad** capacitors.

Please always choose a fuse of equal or slightly higher value (max 10%) than indicated.

Note: The use of MAC2 cooling system is strongly recommended when the amplifier is employed at full power with 1 Ohm stereo or 2 Ohm bridged loads.

VRx1 - VRx2 Multichannel Extensions HL24

Crossover module for VRx1 and VRx2 with independent HI/LO-PASS crossover frequency.

Crossover

12dB/oct. HI-PASS - 24dB/oct. LO-PASS
 F1 frequency range: 40 Hz ÷ 120 Hz
 F2 frequency range: 40 Hz ÷ 90 Hz

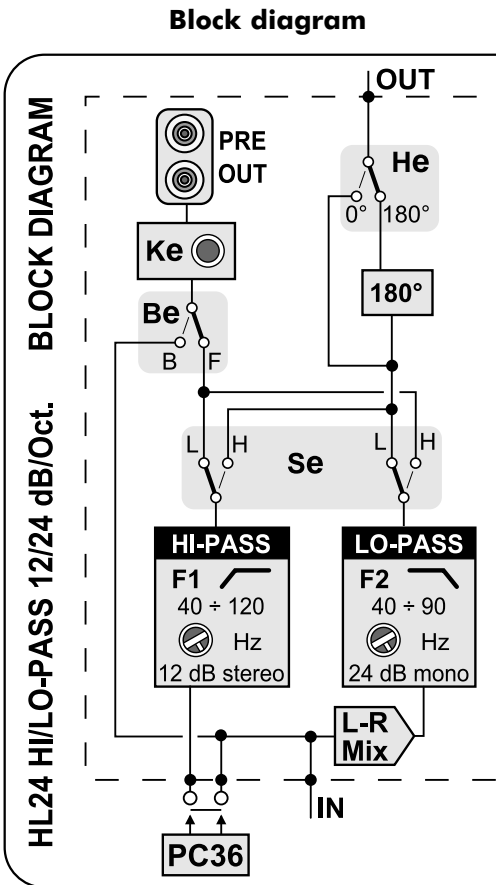

Controls panel

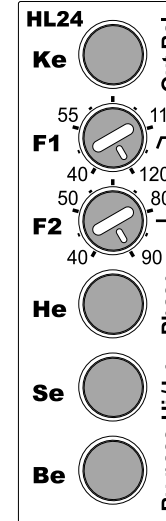

Short guide

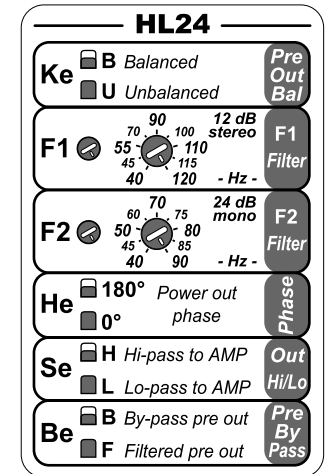

Sticker to put onto VRx1 and VRx2 short guide together with Block Diagram one.

Controls description

- Ke** - BALANCED (B)/UNBALANCED (U) switch for PRE OUT output.
- F1** - 12dB/oct. HI-PASS filter adjustment.
- F2** - 24dB/oct. LO-PASS filter adjustment.
- He** - 0° (0°)/180° (180°) phase shifting switch for amplifier output.
- Se** - HI-PASS (H)/LO-PASS (L) switch for PRE OUT output.
- Be** - BYPASS (B)/FILTERED (F) switch for PRE OUT output.

Module description

LO-PASS section is MONO and mixes R and L channels. HI-PASS section is Stereo. HL24 adds an ABS PRE output to the amplifier it is installed into.

Features

It permits to drive SUB section in MONO with cut at 24dB. Its preamplified HI-PASS output can be sent to another amplifier without crossover or to a VRx2 with HL12 module in order to realise a BAND-PASS section. Module outputs can be exchanged one with the other; in this way, the amplifier where the module is installed can be used for front system; the PRE output can be employed to drive an external amplifier dedicated to SUB.

Uses

HL24 is especially designed for bi-amplified systems since it handles SUB crossover point. It is, however, a very flexible device which allows its use also when other functions are needed. It is the ideal partner for VRx1 and VRx2.

Possible configurations

OUT	PRE OUT	Se HI/LO-PASS	Be BYPASS
		<input type="checkbox"/>	<input type="checkbox"/>
	Bypass	<input type="checkbox"/>	<input type="checkbox"/>
		<input type="checkbox"/>	<input type="checkbox"/>
	Bypass	<input type="checkbox"/>	<input type="checkbox"/>

VRx1 - VRx2 Multichannel Extensions BSA1

Pre input repeater stereo module (BYPASS) for VRx1 and VRx2.

Stereo balanced line repeater

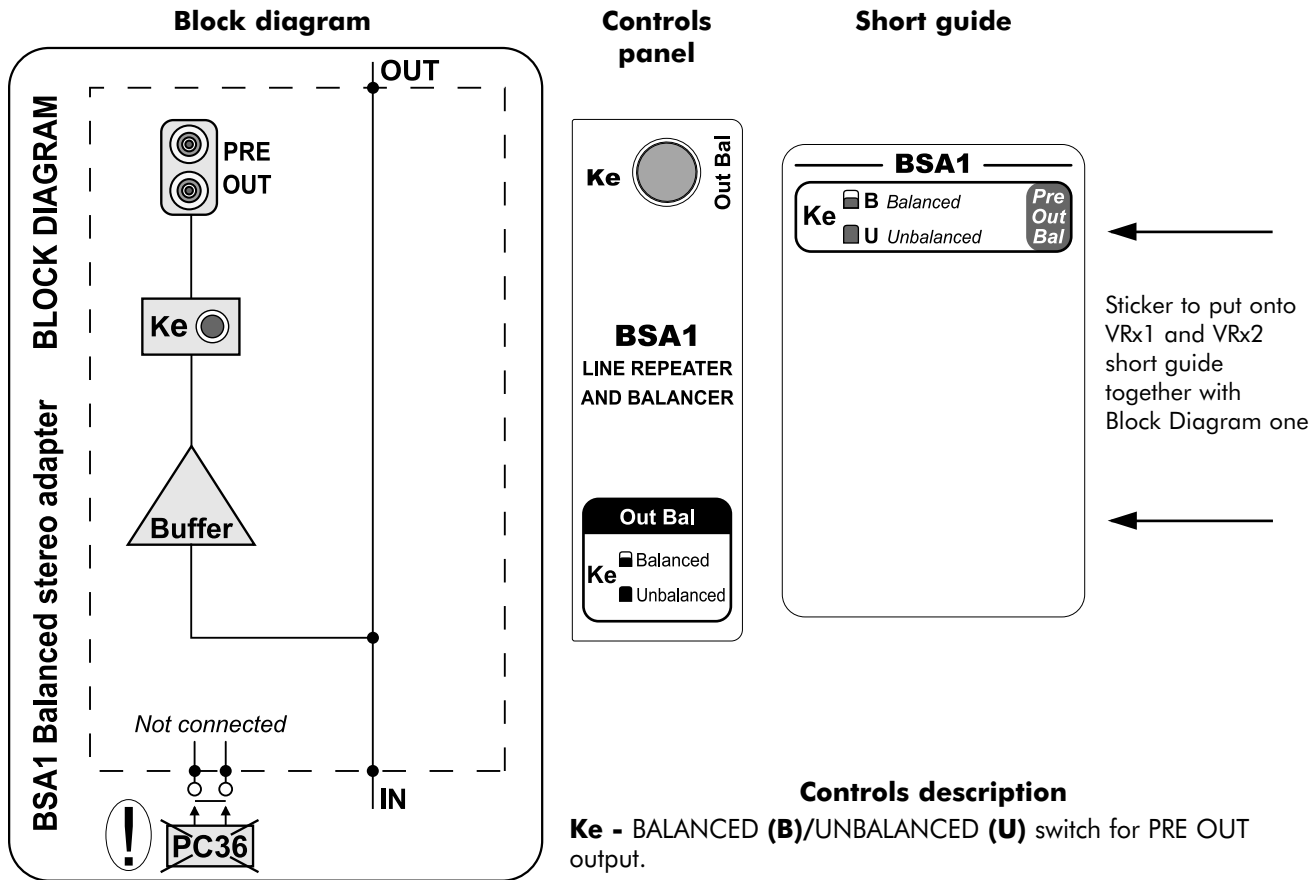

Module description

BSA1 adds an ABS PRE output to the amplifier it is installed into. It permits to amplify and repeat the same frequencies range as VRx amplifier it is installed into.

Note: BSA1 does not have crossover sections; it is therefore not possible to use it with PC36 since the latter must be employed together with a HI-PASS section in order to function in the right way (see part B, p. 5).

Uses

It is especially recommended for VRx1 and VRx2, dedicated to SUB through an external filtered source, when you like to increase the system power. You can add as many amplifiers as you like, connected in cascade.

VRx audison

2000 EDITION VRx4.300



VRx 2.150 - VRx2.250 - VRx2.400 connections

Power supply, remote and accessories

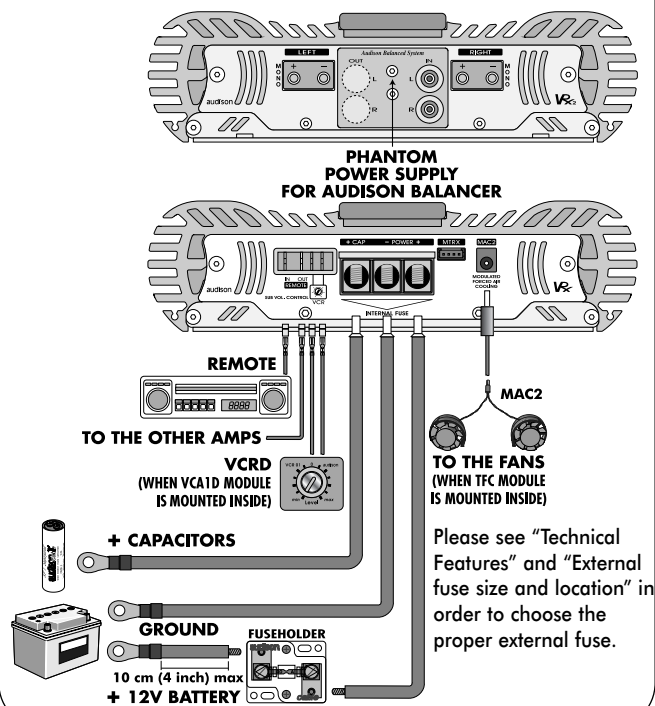

Inputs and outputs: stereo connection

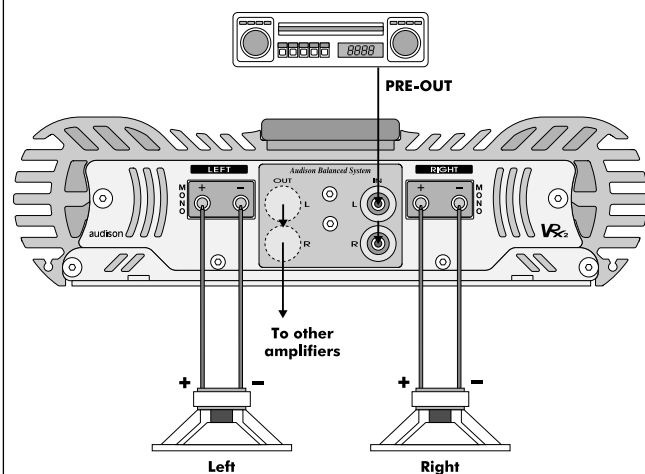

Inputs and outputs: bridge connection

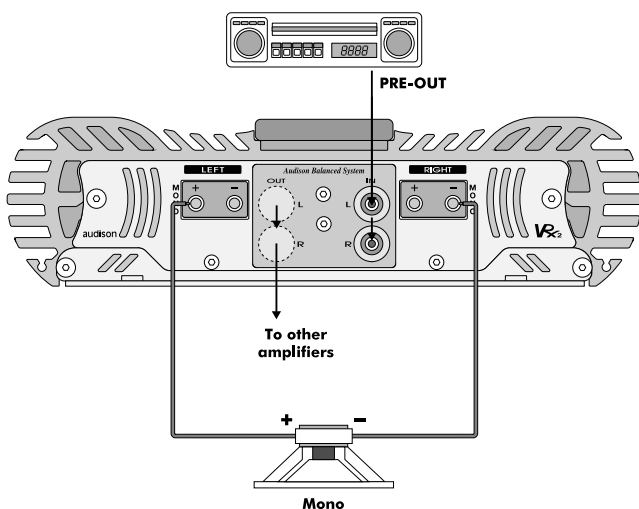

Inputs and outputs: Tri-mode connection

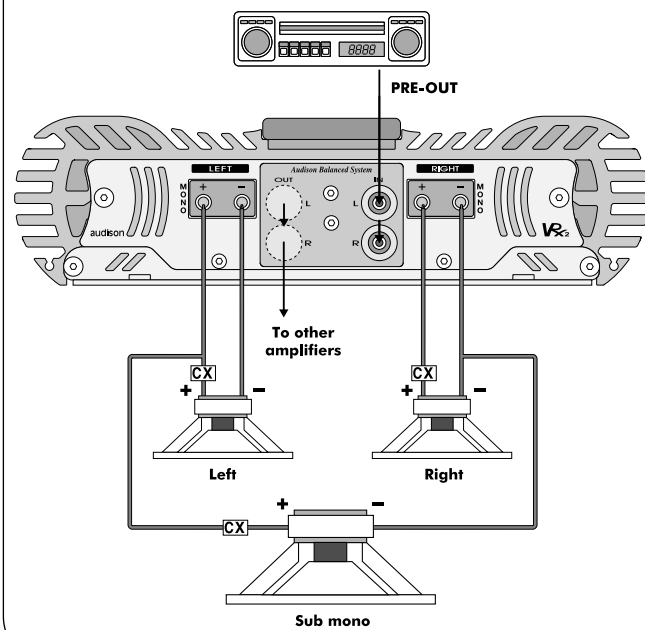

Updating of short guide under wooden strip

VRx1

BLOCK DIAGRAM

See owner's manual before any adjustment.

VRx1 controls

K1 B Balanced Amp in: R only IN Bal
 U Unbalanced Line Noise L N S
K2 OFF Line Noise L N S
ON Suppressor L N S
K3 H 0.15 + 1.5V IN sensitivity range LEVEL x3
 L 0.5 + 5V LEVEL x3
LM 4 8 Level
 2 10 Range K3

PC36 Continuous phase controller
 YH 20 85 120 Phase adjustment
 30 180 Degrees - YB ON PC36 on
 40+200 Hz (factory preset); 200+800 Hz; 800+4500 Hz 3 pos. internal presets
SM24 Subsonic mono filter
 WF 20 25 30 Frequency adjustment
 14 36 - Hz - WB ON SM24 on
DSC1 Dynamic sub control
 PG 10 3.0 5.0 Gain adjustment
 0.0 +2.0 - dB - Standard adj 4 5 6
 2 8 Time delay adjustment
PF 45 15 35 Frequency adjustment
 30 70 - Hz - PT 2 4 6
 0 8

PRM3 Parametric equaliser
 JF 35 70 130 Frequency adjustment
 20 200 - Hz - JB ON PRM3 on
OFF 20 Hz + 200 Hz JB OFF PRM3 by-pass
JM ON Activates JX JL -3 0 +3 Level adjustment
OFF 20 Hz + 200 Hz JL -9 -9 +9 - dB -
JX x100 2 KHz + 20 KHz JQ 1.15 1.2 1.5 Q adjustment
 x10 200 Hz + 2 KHz 1 1.4 1.6 2.4

MULTICHANNEL EXTENSIONS
 HL12 Hi/Lo-pass stereo, 12 dB/Oct.
 LM24 Lo-pass mono, 24 dB/Oct. HL24 Lo-pass mono for Sub, 24 dB/Oct. and Hi-pass stereo, 12 dB/Oct. BSA1 Line repeater and balancer

HL24

Ke B Balanced Pre Out Bal
 U Unbalanced Out Bal
F1 70 90 110 130 150 170 190 210 230 250 270 290 310 330 350 370 390 410 430 450 470 490 510 530 550 570 590 610 630 650 670 690 710 730 750 770 790 810 830 850 870 890 910 930 950 970 990 - Hz - Filter
F2 80 75 70 65 60 55 50 45 40 35 30 25 20 15 10 5 0 - Hz - Filter
He 180° Power out Phase
 0° phase
Se H Hi-pass to AMP Out Hi/Lo
 L Lo-pass to AMP Hi/Lo
Be B By-pass pre out Pre By
 F Filtered pre out Pass

BLOCK DIAGRAM

See owner's manual before any adjustment.

- INCOLLARE QUI LO SCHEMA A BLOCCHI DELLA MULTICHANNEL EXTENSION

- STICK THE MULTICHANNEL EXTENSION BLOCK DIAGRAM HERE

- COLLER ICI LE SCHEMA DE BRANCHEMENT D'EXTENSION MULTICHANNEL

- KLEBEN SIE DAS MULTICHANNEL EXTENSION BLOCK DIAGRAM HIER

VRx2

BLOCK DIAGRAM

See owner's manual before any adjustment.

VRx2 controls

K1 B Balanced Mono in: R only IN Bal
 U Unbalanced Right & mono Left L N S
K2 OFF Line Noise L N S
ON Suppressor L N S
K3 M Mono - IN Right MONO
 S Stereo MONO
K4 H 0.15 + 1.5V IN sensitivity range LEVEL x3
 L 0.5 + 5V LEVEL x3
LL 4 8 L Ch. level L Ch.
 2 10 Range K4
LR 4 8 R (or mono IN) R Ch. level R Ch.
 2 10 Range K4

PC36 Continuous phase controller
 YH 20 85 120 Phase adjustment
 30 180 Degrees - YB ON PC36 on
 40+200 Hz (factory preset); 200+800 Hz; 800+4500 Hz 3 pos. internal presets
SM24 Subsonic mono filter
 WF 20 25 30 Frequency adjustment
 14 36 - Hz - WB ON SM24 on
PRM3 Parametric equaliser
 JF 35 70 130 Frequency adjustment
 20 200 - Hz - JB ON PRM3 on
OFF 20 Hz + 200 Hz JB OFF PRM3 by-pass
JM ON Activates JX JL -3 0 +3 Level adjustment
OFF 20 Hz + 200 Hz JL -9 -9 +9 - dB -
JX x100 2 KHz + 20 KHz JQ 1.15 1.2 1.5 Q adjustment
 x10 200 Hz + 2 KHz 1 1.4 1.6 2.4

MULTICHANNEL EXTENSIONS
 HL12 Hi/Lo-pass stereo, 12 dB/Oct.
 LM24 Lo-pass mono, 24 dB/Oct. HL24 Lo-pass mono for Sub, 24 dB/Oct. and Hi-pass stereo, 12 dB/Oct. BSA1 Line repeater and balancer

HL12

Ke B Balanced Pre Out Bal
 U Unbalanced Out Bal
Fe 150 200 250 300 350 400 450 500 550 600 650 700 750 800 850 900 950 - Hz - Filter
Re x10 400 Hz + 5 KHz
x1 40 Hz + 500 Hz
He 180° Power out Phase
 0° phase
Se H Hi-pass to AMP Out Hi/Lo
 L Lo-pass to AMP Hi/Lo
Be B By-pass pre out Pre By
 F Filtered pre out Pass

- INCOLLARE QUI LO SCHEMA A BLOCCHI DELLA MULTICHANNEL EXTENSION

- STICK THE MULTICHANNEL EXTENSION BLOCK DIAGRAM HERE

- COLLER ICI LE SCHEMA DE BRANCHEMENT D'EXTENSION MULTICHANNEL

- KLEBEN SIE DAS MULTICHANNEL EXTENSION BLOCK DIAGRAM HIER

WHERE TO PUT MODULAR EXTENSIONS

VRx2.400

VRX2C VRx2 controls.
They must not be removed.

MULTICHANNEL EXTENSIONS
HL12 - BH12 - LM24
HL24 - BSA1

LD1 VRx2 driver stages. They must not be removed.

DMRX socket for a future extension. Do not put any modules into it.

CONTROL EXTENSIONS
Socket for:
VCA - VCA1D, given with VCRDK

CONTROL EXTENSIONS
PC36

CONTROL EXTENSIONS
SM24

CONTROL EXTENSIONS
PRM3

TPC VRx2 power supply controller. It must not be removed.

CONTROL EXTENSIONS
TFC
(supplied with MAC2)

Controls under wooden strip

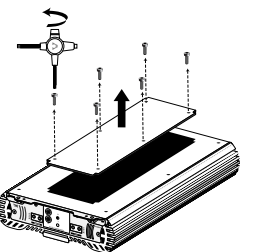
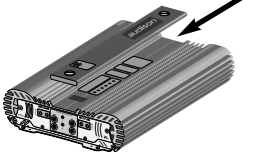
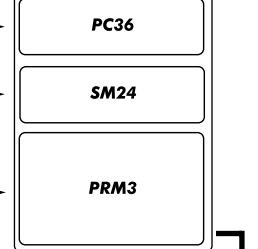
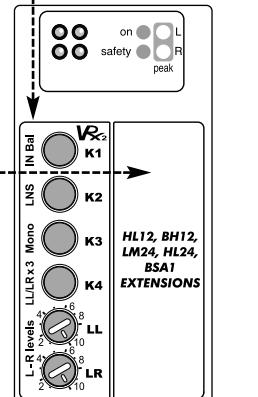

	Serial modules
	Modular Extensions
	BYPO8 bridge: 4+4 Pins
	BYP12 bridge: 6+6 Pins

WHERE TO PUT MODULAR EXTENSIONS

VRx2.150 - VRx2.250

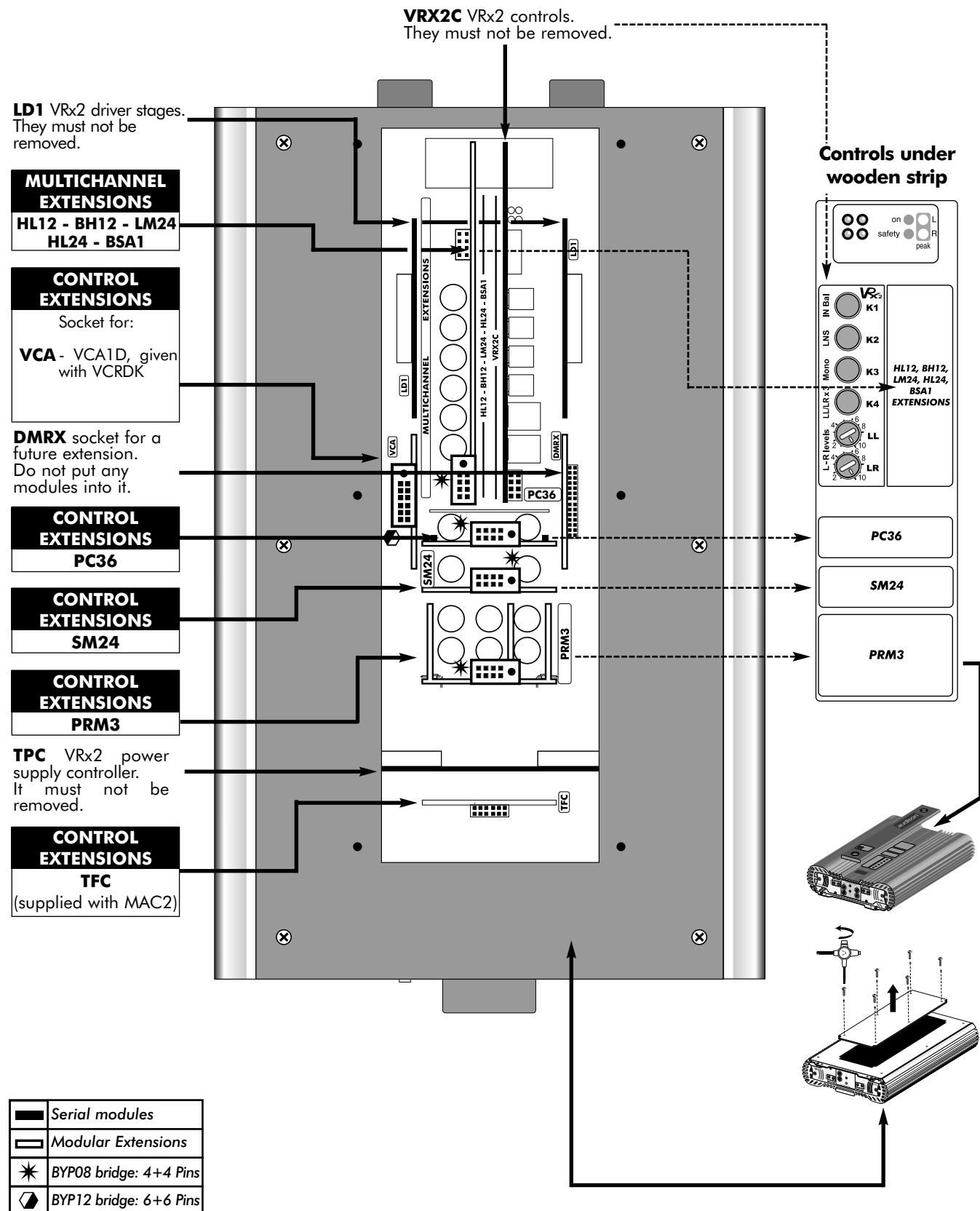

VR_x audison

2000 EDITION

MODULAR EXTENSIONS: COOLING DUCT EXTENSIONS

- Raccords: RC08 - RC10 - RC12
- Terminals: TRM4 - TRM6

WARNING!
Apply to Audison's specialised installation centres for the installation and configuration of modular extensions described in this section

Terminals and Raccords

TRM4

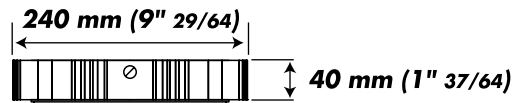

Cooling Duct Extensions are terminals and raccords which have two functions:

- **Esthetical**
- **Technical**

Esthetical function: they cover connections and make installation more elegant.

Technical function: they contain MAC2 kit fans and drive air into the heat sink hollows.

Terminals and Raccords are available in different lengths, in order to be able to realise a system which privileges space for connections or compactness.

TRM6

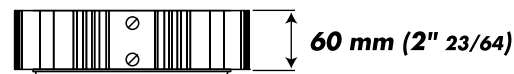

RC08

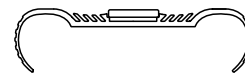
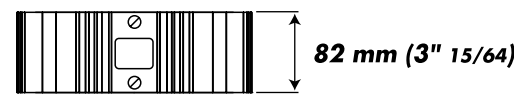

RC10

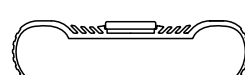
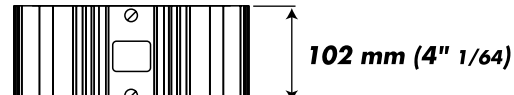

RC12

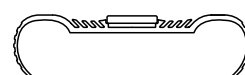
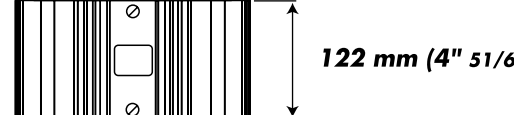

Short guide under wooden strip

It shows output configurations and meaning controls

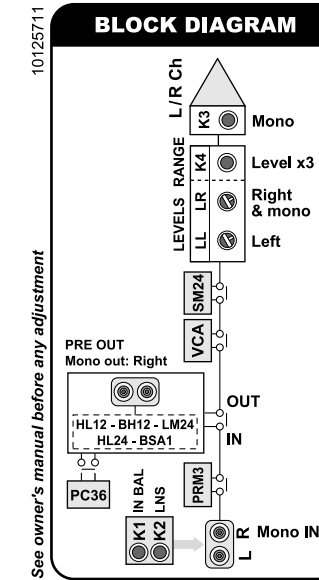

VRx2 controls

K1 B Balanced Mono in: R only U Unbalanced Bal

K2 OFF Line Noise ON Suppressor LNS

K3 M Mono - IN Right S Stereo MONO

K4 H 0.15 ÷ 1.5V IN sensitivity range L 0.5 ÷ 5V LEVEL x3

LL 4 6 8 L ch. level L Ch

LR 4 6 8 R (or mono IN) ch. level R Ch

· INCOLLARE QUI LA GUIDA RAPIDA DELLA MULTICHANNEL EXTENSION

· STICK THE MULTICHANNEL EXTENSION SHORT GUIDE HERE

· COLLER ICI LE RESUME DU MANUAL D'UTILISATION D'EXTENSION MULTICHANNEL

· KLEBEN SIE DIE MULTICHANNEL EXTENSION KURZ-BESCHREIBUNG HIER

· INCOLLARE QUI LO SCHEMA A BLOCCHI DELLA MULTICHANNEL EXTENSION

· STICK THE MULTICHANNEL EXTENSION BLOCK DIAGRAM HERE

· COLLER ICI LE SCHEMA DE BRANCHEMENT D'EXTENSION MULTICHANNEL

· KLEBEN SIE DAS MULTICHANNEL EXTENSION BLOCK DIAGRAM HIER

PC36 Continuous phase controller
 YH ON PC36 on OFF PC36 by-pass
 40÷200 Hz (factory preset); 200÷800 Hz; 800÷4500 Hz 3 pos. internal presets

SM24 Subsonic mono filter
 WF ON SM24 on OFF SM24 by-pass
 SM24 output: mono amp only (K3 on M)

PRM3 Parametric equaliser
 JF ON PRM3 on OFF PRM3 by-pass
 JM ON Activates JX OFF 20 Hz ÷ 200 Hz
 JL Level adjustment - dB -
 JQ Q adjustment

- MULTICHANNEL EXTENSIONS**
- HL12 Hi/Lo-pass stereo, 12 dB/Oct.
 - BH12 Band/Hi-pass stereo, 12 dB/Oct.
 - LM24 Lo-pass mono, 24 dB/Oct.
 - HL24 Lo-pass mono for Sub, 24 dB/Oct. and Hi-pass stereo, 12 dB/Oct.
 - BSA1 Line repeater and balancer

VRx2.150 - VRx2.250 - VRx2.400

Controls and functions

Leds

ON - Green led
It indicates the amplifier is on.

SAFETY - Red led
It indicates protection intervention: excessively high temperature or output anomalies (direct current, short circuit or dangerously low load impedance). Protection intervention stops the amplifier functioning. Switch the amplifier off; when anomaly is eliminated, switch the amplifier on again.

PEAK L - R - Orange leds
They are on when one or more VRx amplifiers are about to reach distortion threshold. They are useful to adjust inputs sensitivity.

Short guide

K1	<input type="checkbox"/> B	Balanced	Mono in: R only	IN
	<input type="checkbox"/> U	Unbalanced		Bal
K2	<input type="checkbox"/> OFF	Line Noise		LNS
	<input type="checkbox"/> ON	Suppressor		S
K3	<input type="checkbox"/> M	Mono - IN Right		MONO
	<input type="checkbox"/> S	Stereo		Ch
K4	<input type="checkbox"/> H	0.15 ÷ 1.5V	IN sensitivity range	LEVEL x3
	<input type="checkbox"/> L	0.5 ÷ 5V		
LL	<input type="checkbox"/> 4	6	L ch. level	L
	<input type="checkbox"/> 2	10	Range K4	Ch
LR	<input type="checkbox"/> 4	6	R (or mono IN) ch. level	R
	<input type="checkbox"/> 2	10	Range K4	Ch

Controls description

K1 - Bal/Unbal inputs switch.

K2 - LNS circuit **ON/OFF** switch for line noise suppression.

K3 - Mono/Stereo switch. In mono, the amplifier input is the one which is commonly used for right channel (**R**).

K4 - It selects **sensitivity range**.

LR, LL - Input **sensitivities adjustment** of right and left channel respectively. When the amplifier is in mono, adjustment is made through **LR**.

Warning - When SM24, mono subsonic filter for SUB, is employed, the amplifier cannot be used in stereo. **K3** has to be set on **Mono**.

Note: In case of installations with more amplifiers connected in cascade, we recommend to put **K2** onto **ON** in the first device (i.e. the one which receives the signal from the head unit), leaving it onto **OFF** in the others. If disturbance persists, you can activate **LNS** anti-noise circuit also in the other amplifiers.

Controls under wooden strip

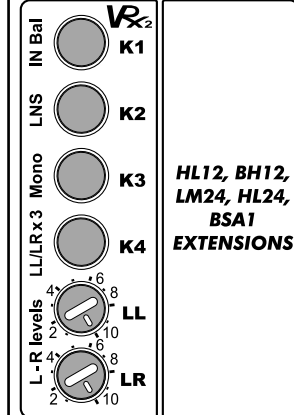

PC36

SM24

PRM3

Terminals: installation of TRM4 and TRM6

Note: Please use the special multispanner supplied with the devices in order to carry out these operations.

How to put logo in the right way in case the amplifier is mounted upside down

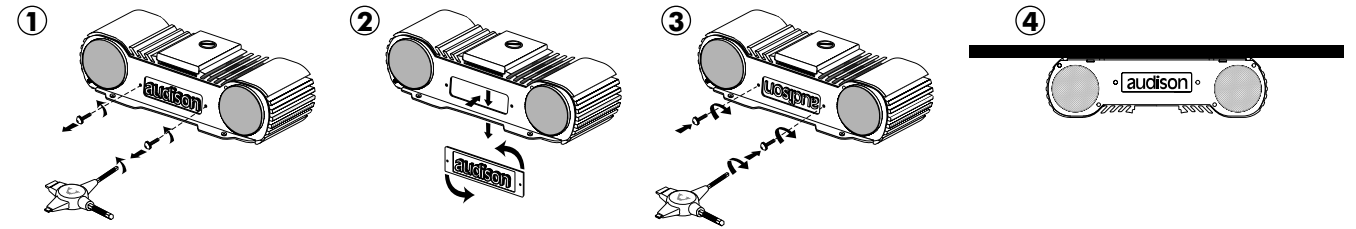
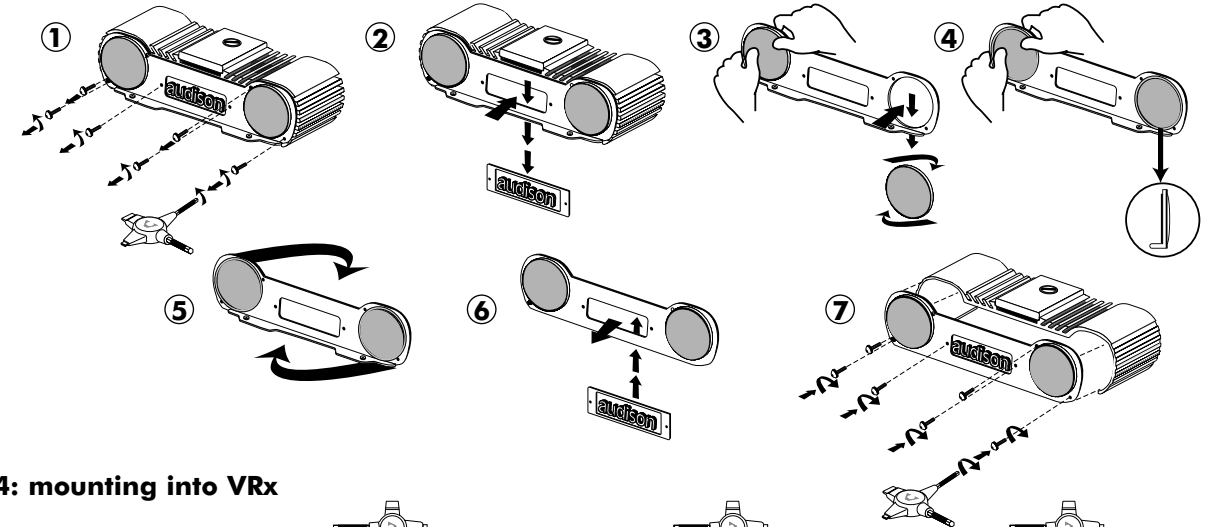
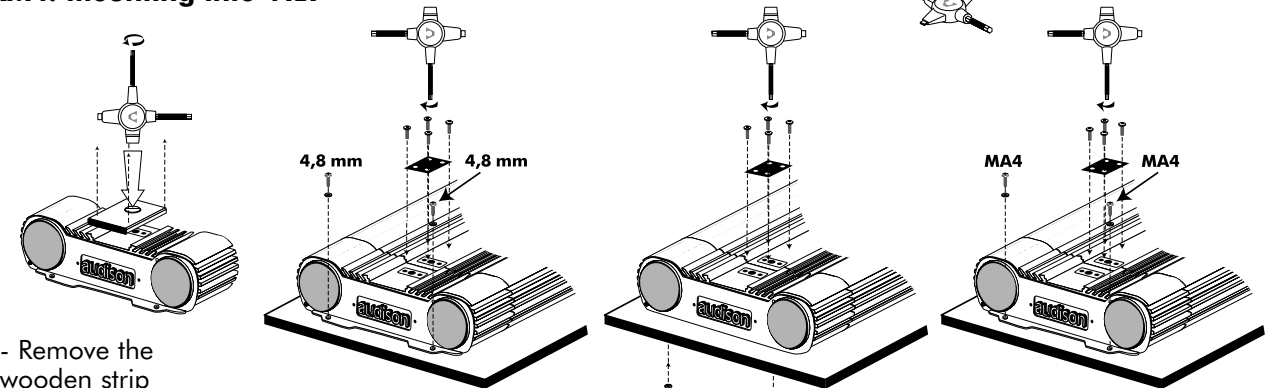

Plate mounting with hidden fixing screws



TRM4: mounting into VRx



① - Remove the wooden strip

② A - Self-tapping screws (Ø 4.8 mm) at sight.

② B - Hidden MA4 screws.

② C - MA4 screws at sight.

TRM6: mounting into VRx

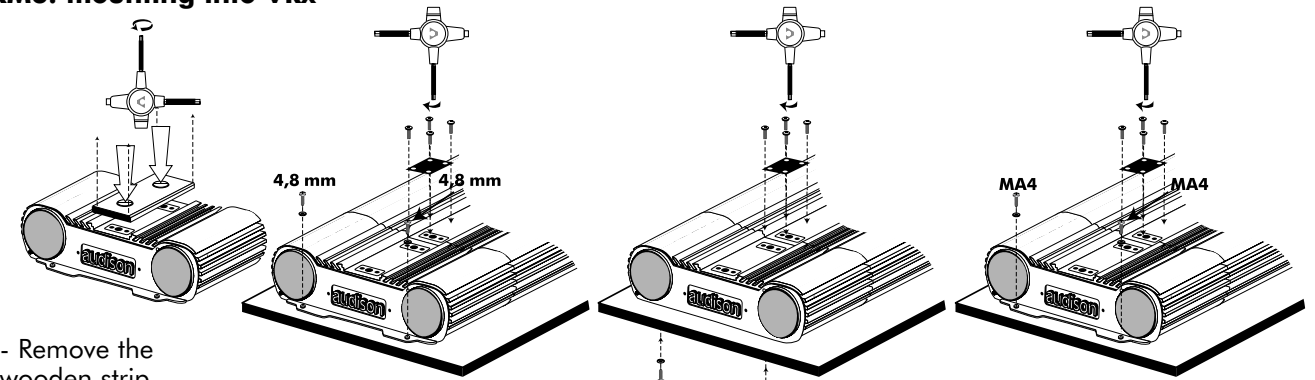

① - Remove the wooden strip

② A - Self-tapping screws (Ø 4.8 mm) at sight.

② B - Hidden MA4 screws.

② C - MA4 screws at sight.

Raccords: installation of RC08, RC10 and RC12

Note: Please use the special multispanner supplied with the devices in order to carry out these operations.

VRx logo fixing into wooden strip

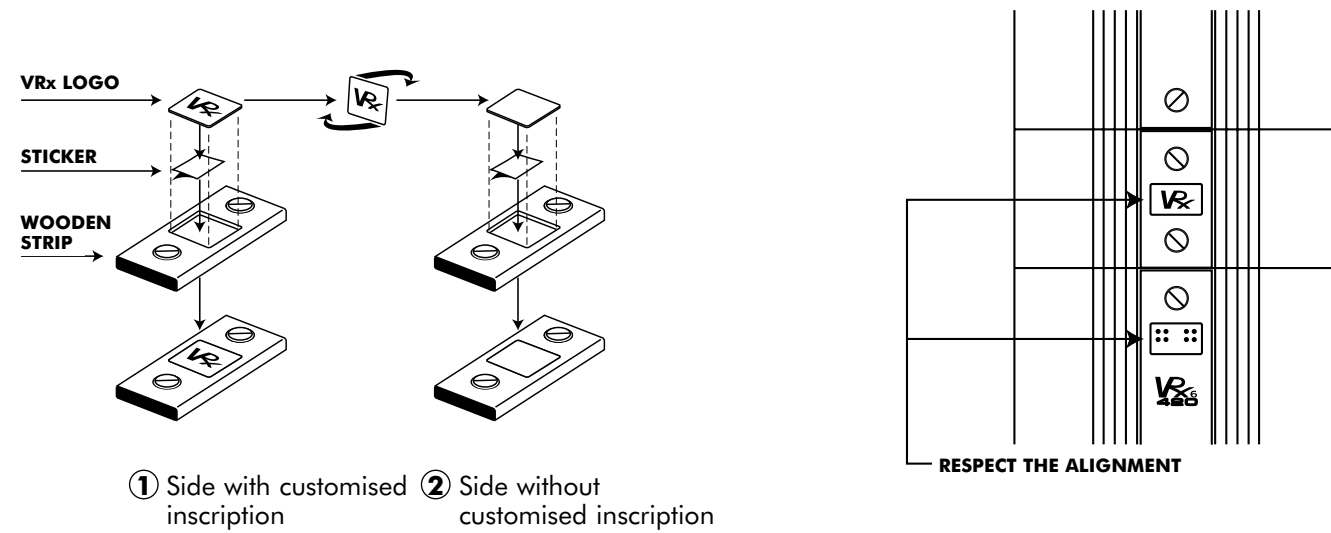

RC08 - RC10 - RC12: fixing onto VRx

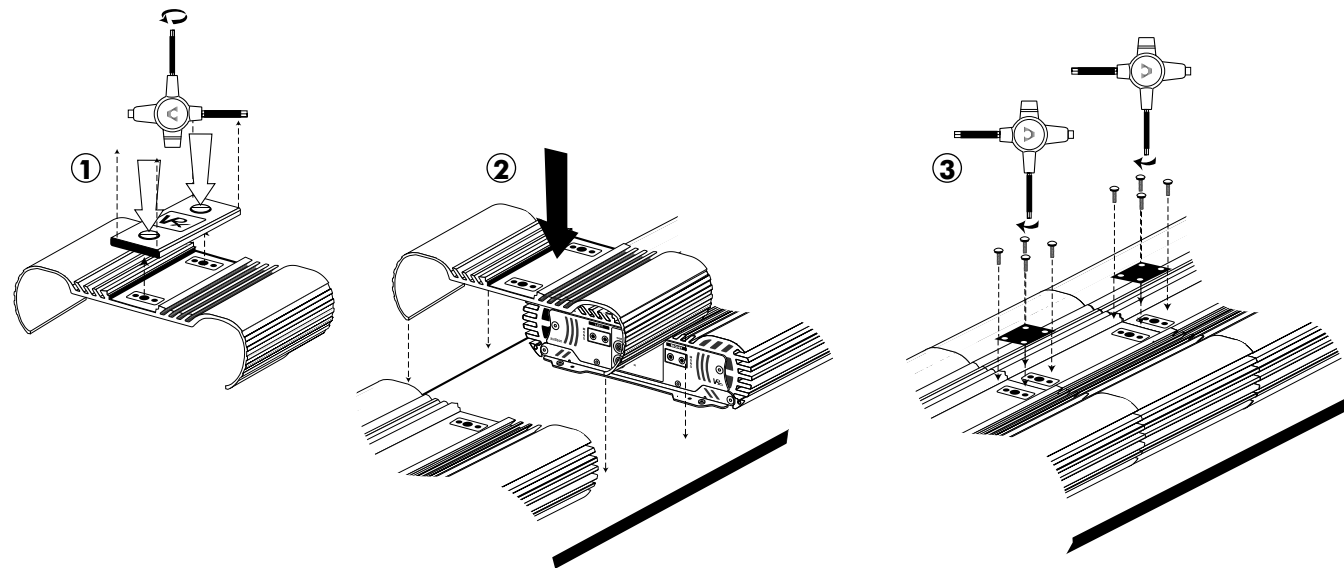

VRx2.150 - VRx2.250 - VRx2.400

Block diagram

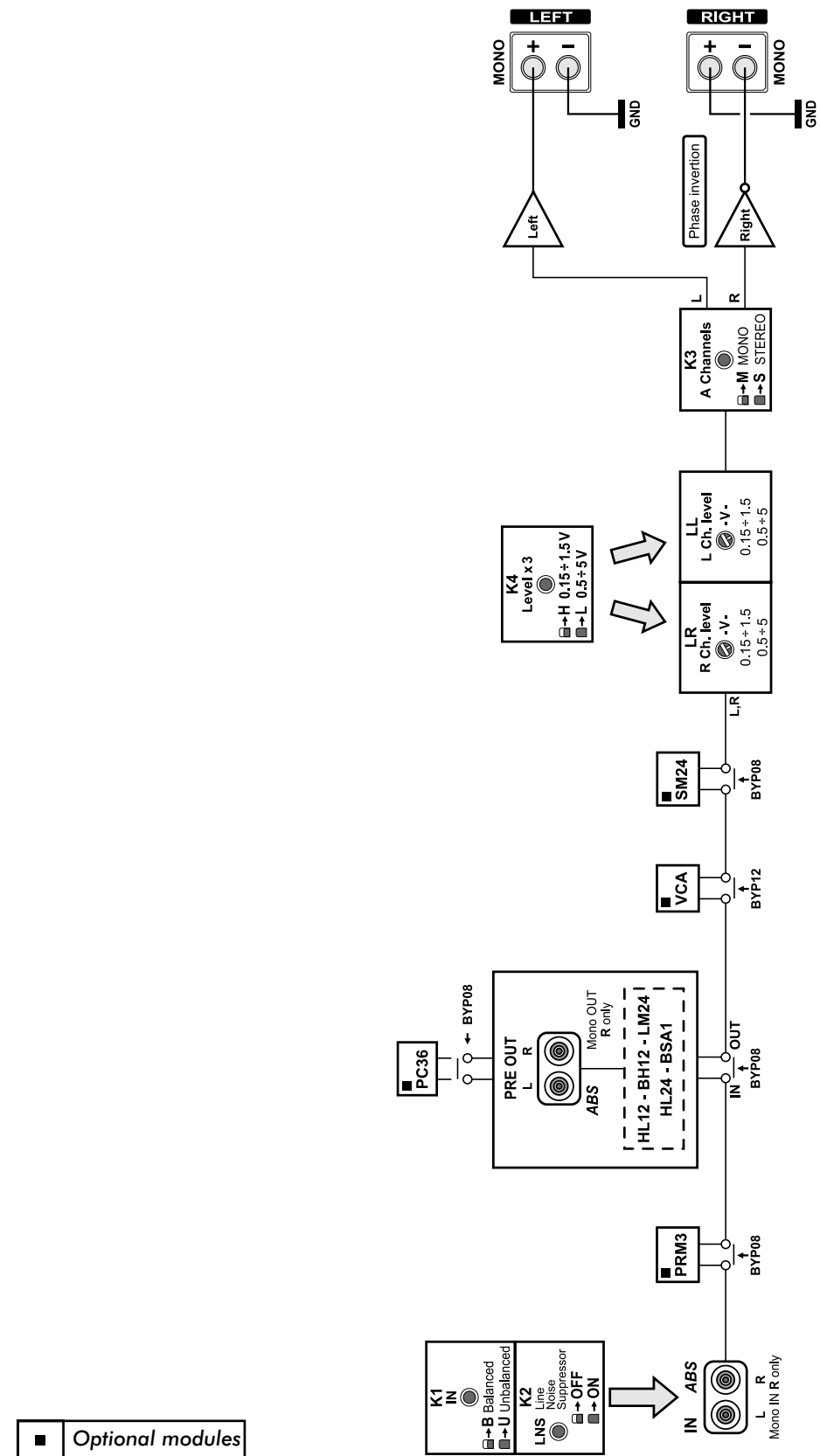

VRx2.400

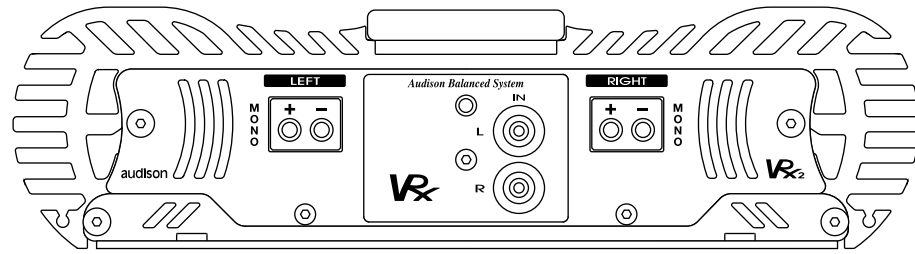

Inputs panel with multichannel extensions:
HL12 - BH12 - LM24
HL24 - BSA1

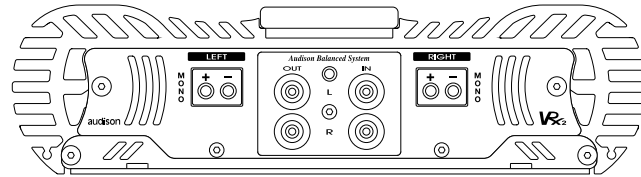

Technical features

POWER SUPPLY	11 ÷ 15 VDC
IDLING CURRENT	2.1 A
IDLING CURRENT WHEN OFF	< 0.04 mA
CONTINUOUS NOMINAL POWER Tol.: (+10%/-5%); 0.3% THD; 12 VDC	
2 ch on 4 Ohms	200 W + 200 W (RMS)
CONTINUOUS POWER Tol.: (+10%/-5%); 1% THD; 12.6 VDC	
2 ch on 4 Ohms	250 W + 250 W (RMS)
CONTINUOUS POWER Tol.: (+10%/-5%); 1% THD; 13.8 VDC	
2 ch on 4 Ohms	250 W + 250 W (RMS)
2 ch on 2 Ohms	450 W + 450 W (RMS)
2 ch on 1 Ohm	580 W + 580 W (RMS)
1 ch bridged on 4 Ohms	900 W (RMS)
1 ch bridged on 2 Ohms	1160 W (RMS)
THD DISTORTION (1 kHz; 90% Nominal Power)	0.02 %
IMD DISTORTION (90% Nominal Power)	0.06 %
BANDWIDTH (-3dB; Nominal Power)	2 Hz ÷ 70 kHz
S/N RATIO (A weighed - 1 VRMS input)	100 dBA
REMOTE IN	7 ÷ 15 VDC
REMOTE OUT	12 VDC - 150 mA
INPUT SENSITIVITY (high)	0.15 ÷ 1.5 VRMS
INPUT SENSITIVITY (low)	0.50 ÷ 5.0 VRMS
INPUT IMPEDANCE	15 kOhms
LOAD IMPEDANCE (stereo)	8 - 4 - 2 - 1 Ohm
LOAD IMPEDANCE (bridged)	8 - 4 - 2 Ohms
SIZE (W x H x D) inches	240 x 64 x 432
SIZE (W x H x D) inches	9.4 x 2.5 x 17
INTERNAL FUSE	100A

ABSORBED CURRENT AT MAXIMUM MUSICAL POWER - EXTERNAL FUSE CHOICE

13.8V - 4 Ohms stereo or 8 Ohms bridged35 A
13.8V - 2 Ohms stereo or 4 Ohms bridged65 A
13.8V - 1 Ohm or 2 Ohms bridged97 A

Measures were realised through a test-set consisting of Rohde & Schwarz UPD audio analyser, HP 6453A power supply (200A continuous) and 14F capacitive booster made with **audison cable Supertarad** capacitors.

Please always choose a fuse of equal or slightly higher value (max 10%) than indicated.

Note: The use of MAC2 cooling system is strongly recommended when the amplifier is employed at full power with 1 Ohm stereo or 2 Ohm bridged loads.

Wooden strip removal

You need to remove the wooden strip which protects calibration and configuration controls in order to act onto them. The wooden strip removal is also necessary to install modular extensions which require the plate replacement: PRM3, SM24, PC36, DSC1, HL12, BH12, HL24, LM24, BSA1.

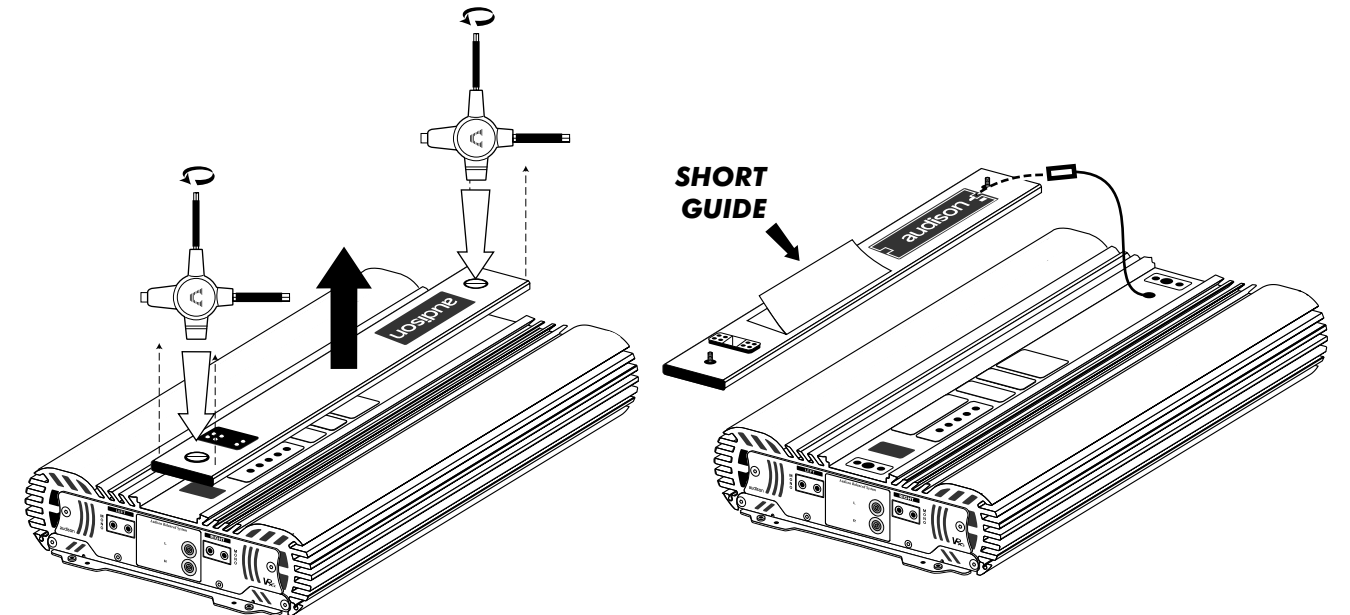

Unscrew the two fixing screws.

Disconnect the wire for logo illumination.

Illuminated logo rotation

It is sometimes necessary to install VRx so that its **audison** logo is upside down. Rotate it of 180° according to the instructions written below in order to have it in the right position again.

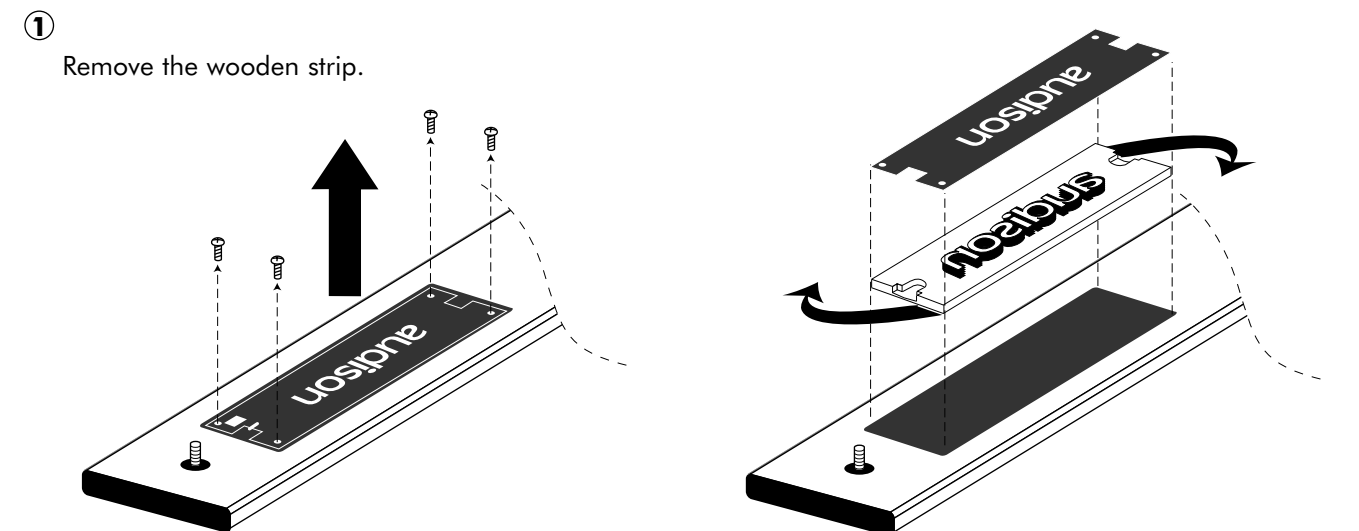

① Remove the wooden strip.

② Turn the wooden strip upside down and unscrew the four screws.

③ Lift the printed circuit and rotate the transparent inscription of 180° (as from drawing). Mount everything back again.

VRx2.250

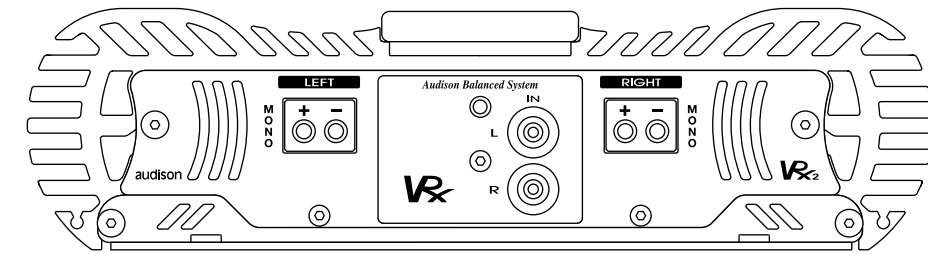

**Inputs panel with
multichannel
extensions:
HL12 - BH12 - LM24
HL24 - BSA1**

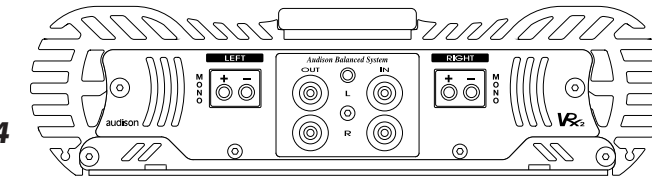

Technical features

POWER SUPPLY	.11 ÷ 15 VDC
IDLING CURRENT	.1.7 A
IDLING CURRENT WHEN OFF	< 0.04 mA
CONTINUOUS NOMINAL POWER Tol.: (+10%/-5%); 0.3% THD; 12 VDC	
2 ch on 4 Ohms	.125 W + 125 W (RMS)
CONTINUOUS POWER Tol.: (+10%/-5%); 1% THD; 12,6 VDC	
2 ch on 4 Ohms	.160 W + 160 W (RMS)
CONTINUOUS POWER Tol.: (+10%/-5%); 1% THD; 13,8 VDC	
2 ch on 4 Ohms	.160 W + 160 W (RMS)
2 ch on 2 Ohms	.280 W + 280 W (RMS)
2 ch on 1 Ohm	.420 W + 420 W (RMS)
1 ch bridged on 4 Ohms	.560 W (RMS)
1 ch bridged on 2 Ohms	.840 W (RMS)
THD DISTORTION (1 kHz; 90% Nominal Power)	.0.02 %
IMD DISTORTION (90% Nominal Power)	.0.06 %
BANDWIDTH (-3dB; Nominal Power)	.2 Hz - 70 kHz
S/N RATIO (A weighed - 1 VRMS input)	.100 dBA
REMOTE IN	.7 ÷ 15 VDC
REMOTE OUT	.12 VDC - 150 mA
INPUT SENSITIVITY (high)	.0.15 ÷ 1.5 VRMS
INPUT SENSITIVITY (low)	.0.50 ÷ 5.0 VRMS
INPUT IMPEDANCE	.15 kOhms
LOAD IMPEDANCE (stereo)	.8 - 4 - 2 - 1 Ohm
LOAD IMPEDANCE (bridged)	.8 - 4 - 2 Ohms
SIZE (W x H x D) mm	.240 x 64 x 382
SIZE (W x H x D) inches	.9.4 x 2.5 x 15
INTERNAL FUSE	.60A

ABSORBED CURRENT AT MAXIMUM MUSICAL POWER - EXTERNAL FUSE CHOICE

13.8V - 4 Ohms stereo or 8 Ohms bridged	.19 A
13.8V - 2 Ohms stereo or 4 Ohms bridged	.36 A
13.8V - 1 Ohm or 2 Ohms bridged	.59 A

Measures were realised through a test-set consisting of Rohde & Schwarz UPD audio analyser, HP 6453A power supply (200A continuous) and 14F capacitive booster made with **audison cable Superfarad** capacitors.

Please always choose a fuse of equal or slightly higher value (max 10%) than indicated.

Note: The use of MAC2 cooling system is strongly recommended when the amplifier is employed at full power with 1 Ohm stereo or 2 Ohm bridged loads.

VRx2.150

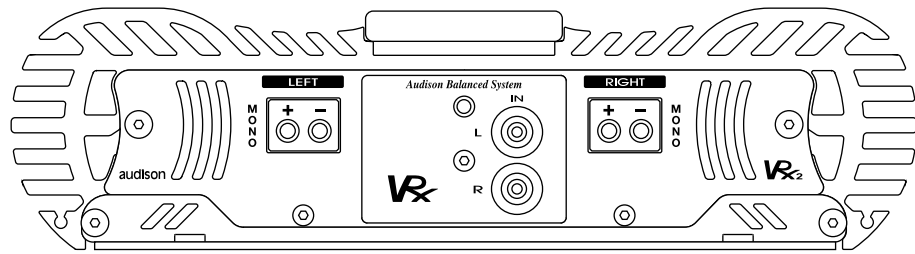

**Inputs panel with
multichannel
extensions:
HL12 - BH12 - LM24
HL24 - BSA1**

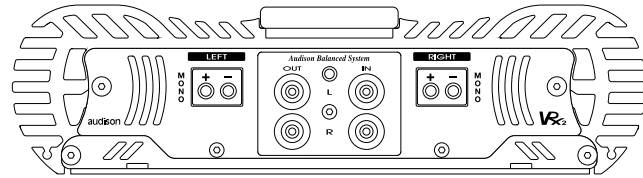

Technical features

POWER SUPPLY	11 ÷ 15 VDC
IDLING CURRENT	1.4 A
IDLING CURRENT WHEN OFF	< 0.04 mA
CONTINUOUS NOMINAL POWER Tol.: (+10%/-5%); 0.3% THD; 12 VDC	
2 ch on 4 Ohms	75 W + 75 W (RMS)
CONTINUOUS POWER Tol.: (+10%/-5%); 1% THD; 12,6 VDC	
2 ch on 4 Ohms	110 W + 110 W (RMS)
CONTINUOUS POWER Tol.: (+10%/-5%); 1% THD; 13,8 VDC	
2 ch on 4 Ohms	110 W + 110 W (RMS)
2 ch on 2 Ohms	180 W + 180 W (RMS)
2 ch on 1 Ohm	240 W + 240 W (RMS)
1 ch Bridged on 4 Ohms	360 W (RMS)
1 ch Bridged on 2 Ohms	480 W (RMS)
THD DISTORTION (1 kHz; 90% Nominal Power)	0.02 %
IMD DISTORTION (90% Nominal Power)	0.04 %
BANDWIDTH (-3dB; Nominal Power)	2 Hz ÷ 70 kHz
S/N RATIO (A weighed - 1 VRMS input)	100 dBA
REMOTE IN	7 ÷ 15 VDC
REMOTE OUT	12 VDC - 150 mA
INPUT SENSITIVITY (high)	0.15 ÷ 1.5 VRMS
INPUT SENSITIVITY (low)	0.50 ÷ 5.0 VRMS
INPUT IMPEDANCE	15 kOhms
LOAD IMPEDANCE (stereo)	8 - 4 - 2 - 1 Ohm
LOAD IMPEDANCE (bridged)	8 - 4 - 2 Ohms
SIZE (W x H x D) mm	240 x 64 x 332
SIZE (W x H x D) inches	9.4 x 2.5 x 13
INTERNAL FUSE	40A

ABSORBED CURRENT AT MAXIMUM MUSICAL POWER - EXTERNAL FUSE CHOICE

13.8V - 4 Ohms stereo or 8 Ohms bridged	14 A
13.8V - 2 Ohms stereo or 4 Ohms bridged	23 A
13.8V - 1 Ohm stereo or 2 Ohms bridged	37 A

Measures were realised through a test-set consisting of Rohde & Schwarz UPD audio analyser, HP 6453A power supply (200A continuous) and 14F capacitive booster made with **audison cable Superfarad** capacitors.

Please always choose a fuse of equal or slightly higher value (max 10%) than indicated.

Note:

The use of MAC2 cooling system is strongly recommended when the amplifier is employed at full power with 1 Ohm stereo or 2 Ohm bridged loads.

VRx

audison

2000 EDITION

VRx INSTALLATION

- General recommendations
- Cables size
- External fuse size and location
- Internal fuse replacement
- VRx size

GENERAL RECOMMENDATIONS

Audison would like to thank you for choosing this product. Before the information relative to its use, please carefully read the safety norms you have to respect in order to avoid unpleasant inconveniences and to get the best enjoyment.

WARNING!

- Do not remove the cover in order to reduce the risk of serious technical inconveniences.
- Please apply to qualified staff for every necessary intervention inside the amplifier.
- For safe driving, we advise to listen to music at a volume level which won't draw external traffic sounds.

WARNINGS

INPUTS: If the source does not share the output ground with the chassis and if you hear parasite noise, the braided shield of the shielded cable has to be connected to the source chassis.

OUTPUTS: Never connect -R and -L outputs to ground or to each other. If a crossover filter is used, be sure its two channels do not have a common ground.

ADJUSTMENTS: Please act as follows in order to calibrate the amplifiers level in the right way:

- Select the most suitable sensitivity range (0.15÷1.5V or 0.5÷5.0V) to the source you want to use through the proper switch.
- Turn the amplifiers level controls towards minimum sensitivity (range ref.: 2).
- Put the source volume control around 3/4 of maximum level and start a very dynamic musical track.
- Turn the amplifiers level controls towards maximum sensitivity (range ref: 10) in order to cause the intermittent lighting of the proper saturation leds (peak).

In multichannel amplification, levels adjustment must be optimised in order to get the maximum balance between the different ways of the system.

PRECAUTIONS

WARNING!

This amplifier must be exclusively used into vehicles and boats with 12 Volt power supply in direct current (12V d.c.), with negative to ground. It is **IMPORTANT NOT TO USE** any other kinds of electric power supply in order to avoid fires or possible electrocutions.

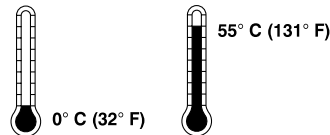

Do not use VRx if temperature is below 0°C (32°F) or above 55°C (131°F).

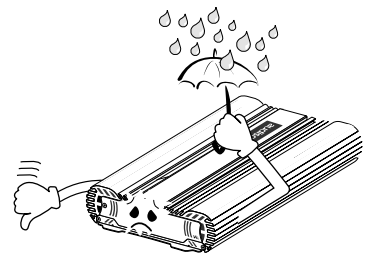

Do not make VRx touch liquids.

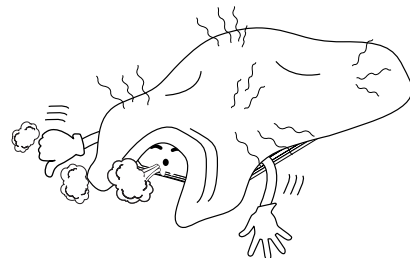

Do not cover VRx heat sink and do not obstruct its cooling ducts.

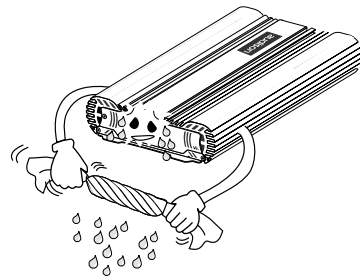

Do not use VRx in case of extreme humidity conditions (<10% or >90%).

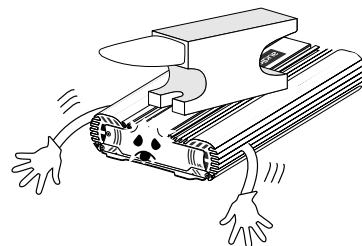

Do not put heavy objects onto VRx.

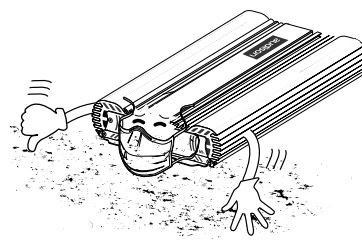

Avoid to install VRx in dusty or dirty places.

VRx

audison

2000 EDITION VRx2.150

VRx2.250

VRx2.400



CABLES SIZE

Power supply cables

Power supply cables size is very important since quality of the amplifier performances, reliability and, above all, installation safety depend on it. As this matter is complex, varied and important, we recommend you to address **audison**'s specialised centres, where highly qualified professionals will be able to carry out these operations in the best way, realising a state-of-the-art installation.

Signal cables

Used signal cables must be of the highest quality in order to allow music perfect reproduction preserving it from disturbances or dispersion.

VRx amplifiers perform at their best when they are used in balanced configuration, which minimises the problems due to disturbances and noise. **audison cable** catalogue makes the exclusive **ABS** connections system available in order to realise it.

It is also possible to opt for an unbalanced connection system; you can choose among a wide variety of good quality models in **audison cable** catalogue to make it.

audison cable ABS connections (international patent) solve the problems relative to the big size of connectors normally used for balanced configuration in an extremely reliable, elegant and practical way. Their compatibility with standard RCA connectors allows the user to act freely during the installation. 24K gold-plated and mechanically refined, they are a reference for really hi-end systems.

Speaker cables

Speaker cables section will have to be as big as possible and anyway not lower than 2.1mm² (14 AWG) in order to obtain:

- excellent damping on the speaker;
- wide safety margin;
- very good transfer of musical signal.

audison cable catalogue includes a wide choice of models which can satisfy all needs.

We recommend you to apply to **audison**'s specialised centres where highly qualified professionals will be able to carry out these operations in the best way, realising a state-of-the-art installation.

EXTERNAL FUSE SIZE AND LOCATION

External fuse size must be calculated according to the type of system you want to realise and to its being made of a single amplifier or multiamplified.

System with a single amplifier

In case of a system with a single amplifier, please refer to item: "Absorbed current at maximum musical power", written in the Technical Features of the used amplifier, in order to calculate the external fuse value.

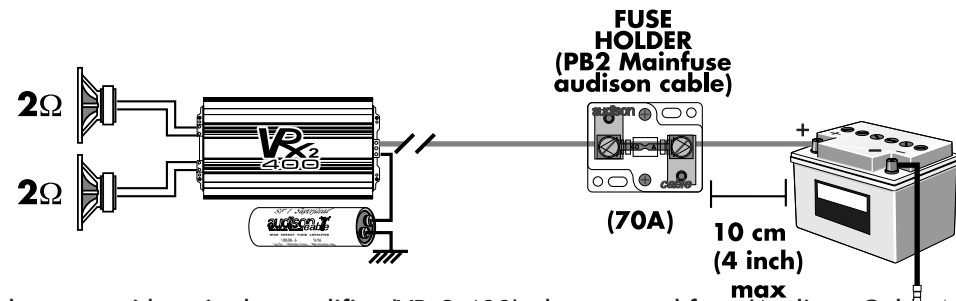

In a hypothetical system with a single amplifier (VRx2.400), the external fuse (Audison Cable MAINFUSE) value for a 2 Ohm load would be 70A, rounding off what written in the Technical Features (65A).

Note: Values and models of the example are purely indicative and **only used to explain the calculation procedure.**

We recommend to use Audison Cable MAINFUSE devices as fuse holder.

Multiamplified system

In case of a multiamplified system, you have to sum the absorption of every used amplifier according to the applied load in order to get the external fuse value.

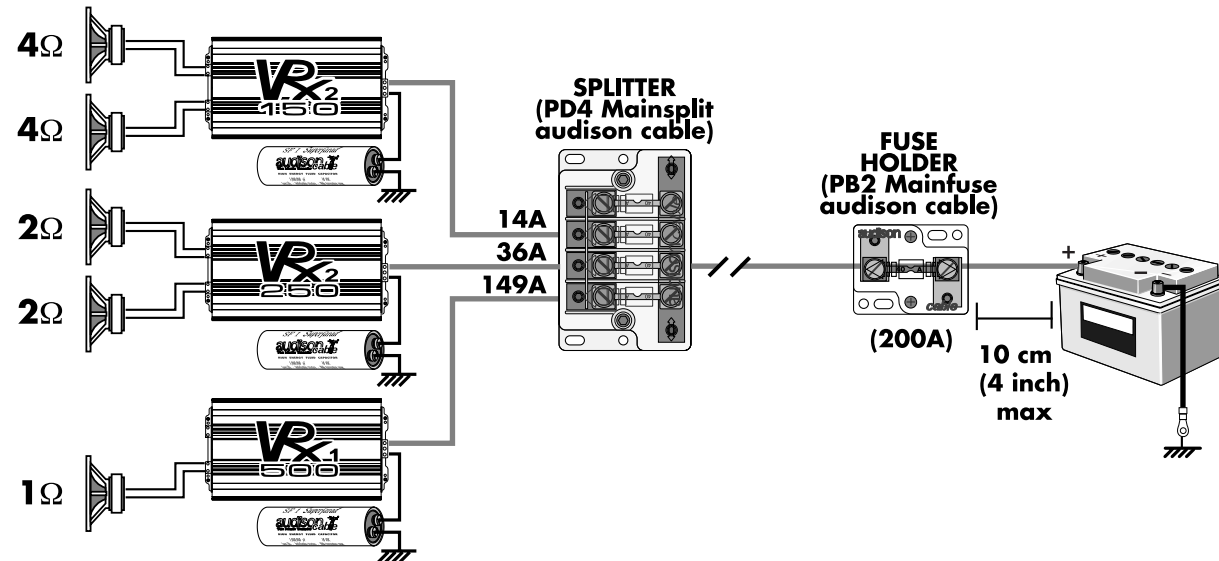

In a hypothetical system consisting of three amplifiers (VRx2.150 – VRx2.250 – VRx1.500), the external fuse value would be thus defined by the sum:

$$\begin{array}{l} 14A \text{ (VRx2.150 on } 4\Omega \text{ load, see Technical Features)} \\ 36A \text{ (VRx2.250 on } 2\Omega \text{ load)} \\ 149A \text{ (VRx1.500 on } 1\Omega \text{ load)} \end{array} \rightarrow (14+36+149)A = 199A \rightarrow 200A$$

Note: Values and models of the example are purely indicative and **only used to explain the calculation procedure.**

We recommend to use Audison Cable MAINSPLIT as splitter (power distribution block), which contains proper locations for further fuses. Obviously, the size of the latter will have to be defined according to the single amplifier absorption, depending on applied load.

We recommend to use Audison Cable MAINFUSE devices as fuse holder.

VRx1.500 connections

Power supply, remote and accessories

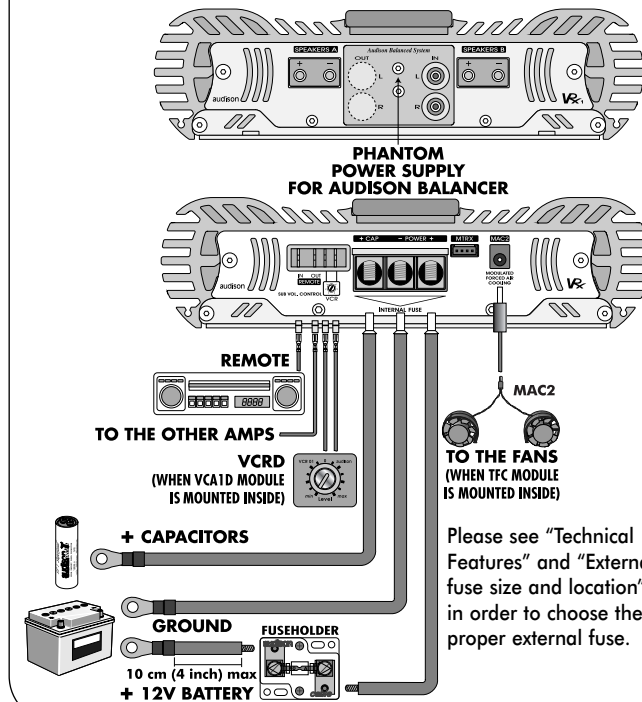

Please see "Technical Features" and "External fuse size and location" in order to choose the proper external fuse.

Inputs and outputs: one or two speakers in parallel

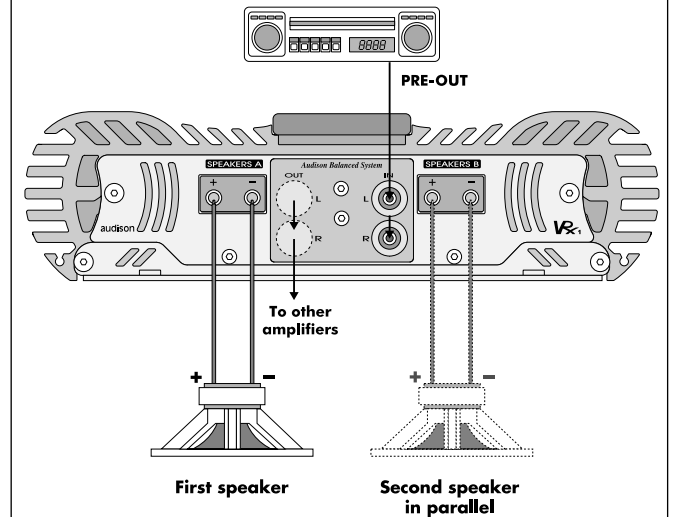

Inputs and outputs: double voice coil speaker with voice coils in parallel

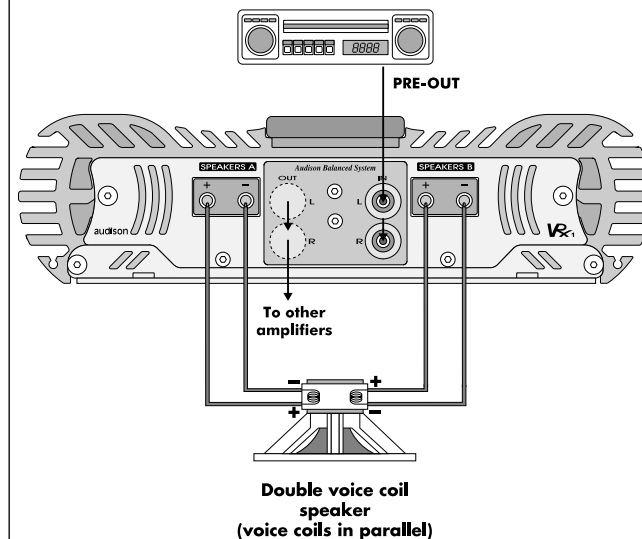

WARNING

When VRx1.500 is used with low impedance loads (1 Ohm), it supplies 2000W approx. and absorbs high currents (300 A approx. in impulsive functioning). In order to get the best performances by the system and the **car safety**, it is necessary to carefully choose the right size of power supply and speaker cables, fuse and fuse holder, battery and power supply distribution systems. **Connections safety** must be also carefully checked in order to avoid voltage drops implying **overheating**.

WHERE TO PUT MODULAR EXTENSIONS

VRx1.500

VR1C VRx1 controls.
They must not be removed.

MULTICHANNEL EXTENSIONS
HL12 - LM24
HL24 - BSA1

DMRX socket for a future extension. Do not put any modules into it.

CONTROL EXTENSIONS

Socket for:

VCA - VCA1D, given with VCRDK

CONTROL EXTENSIONS

PC36

CONTROL EXTENSIONS

SM24

DHF VRx1 driver stage.
It must not be removed.

CONTROL EXTENSIONS

DSC1

CONTROL EXTENSIONS

PRM3

TPC VRx1 power supply controller.
It mustn't be removed.

CONTROL EXTENSIONS

TFC

(supplied with MAC2)

	Serial modules
	Modular Extensions
	BYP08 bridge: 4+4 Pins
	BYP12 bridge: 6+6 Pins

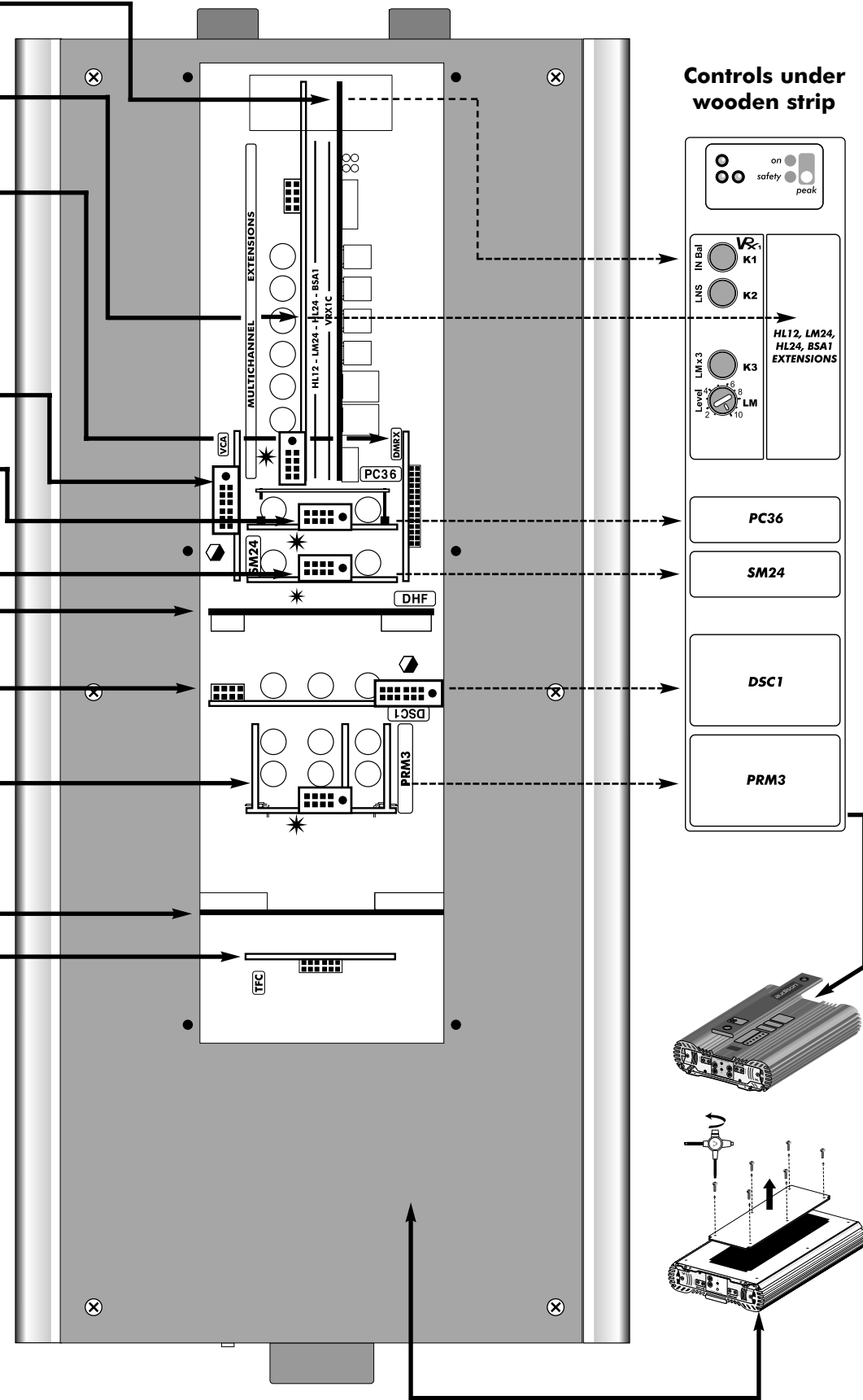

INTERNAL FUSE REPLACEMENT

WARNING!

Before installing a new fuse, please remember to charge the external capacitor (if it is installed) through the special charge-discharge device supplied with Audison Cable Superfarad models. This procedure will prevent all current destined to the external capacitor from passing through the new fuse instantaneously, causing dangerous sparks.

1 - Remove the transparent cover which protects fuse holder location.

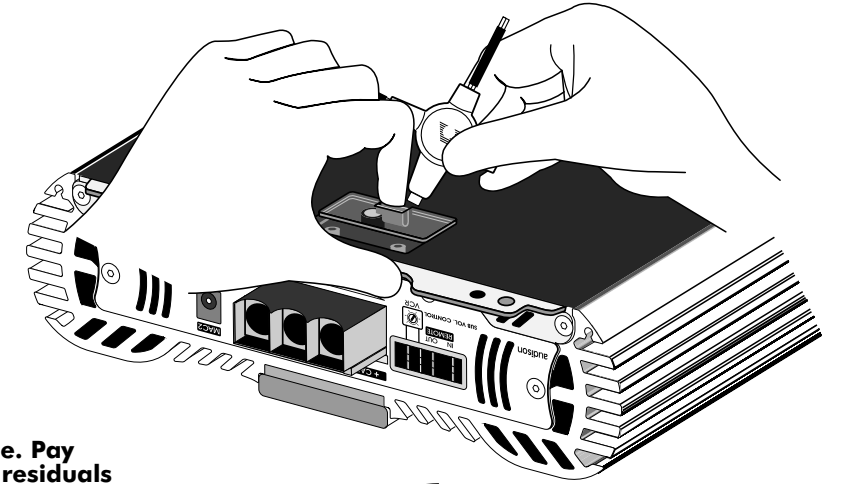

2 - Remove the screws which fasten the fuse. Pay attention not to throw the interrupted fuse residuals inside the device.

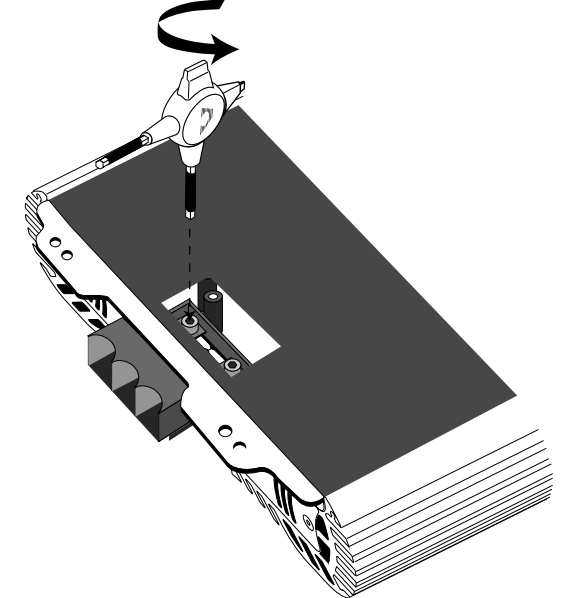

3 - Check the value of the fuse you have to insert (refer to the value indicated in the fuse location if it is used with not particularly difficult loads).

4 - Insert and fix the new fuse by fastening the two screws gradually and alternately, in order to avoid voltage drops along the line and to make the device perfect functioning easier.

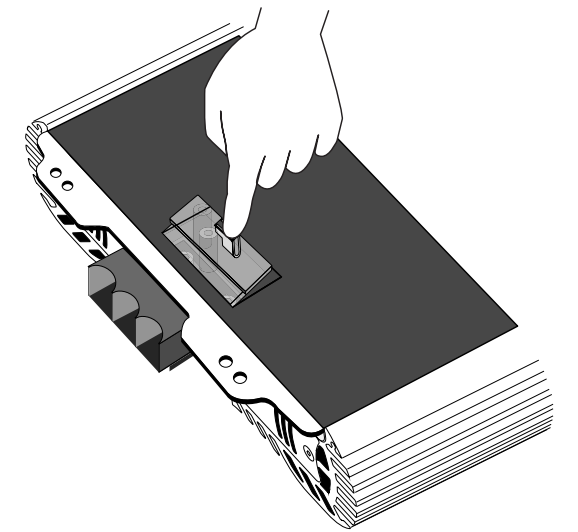

5 - Close the location through the transparent cover.

VRx size

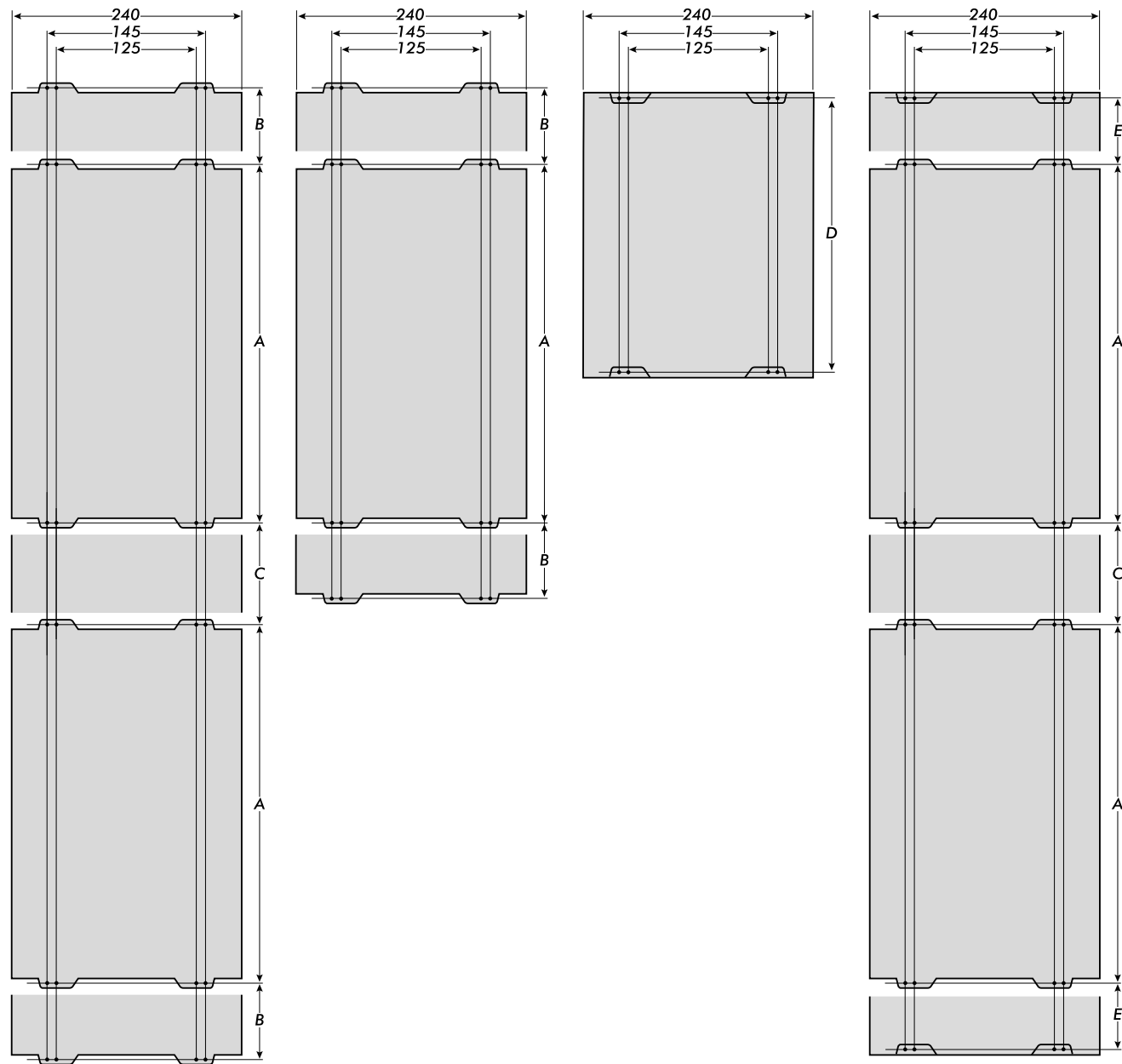

mm	VR ₁ 500	VR ₂ 150	VR ₃ 250	VR ₄ 400	VR ₆ 300	VR ₆ 420	TRM4	TRM6	RC08	RC10	RC12
A	420	320	370	420	475	560					
B							39,5	59,5			
C									62	82	102
D	383	283	333	383	438	523					
E							22	42			

VRx1.500

Short guide under wooden strip

It shows outputs configurations and controls meaning

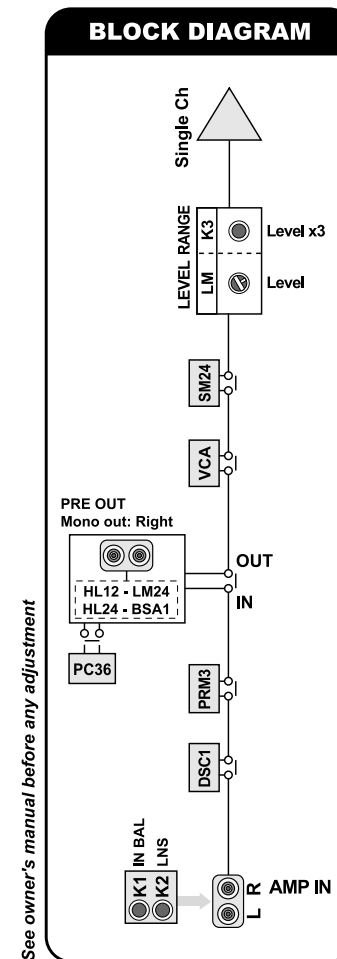

See owner's manual before any adjustment

• INCOLLARE QUI LO SCHEMA A BLOCCHI DELLA MULTICHANNEL EXTENSION

• STICK THE MULTICHANNEL EXTENSION BLOCK DIAGRAM HERE

• COLLER ICI LE SCHEMA DE BRANCHEMENT D'EXTENSION MULTICHANNEL

• KLEBEN SIE DAS MULTICHANNEL EXTENSION BLOCK DIAGRAM HIER

VR_{x1} controls

K1 B Balanced Amp in: R only U Unbalanced **Bal**

K2 OFF Line Noise Suppressor **LNS**

K3 H 0.15 ÷ 1.5V IN sensitivity range L 0.5 ÷ 5V **LEVEL x3**

LM 4 6 8 10 Level **LEVEL**

PC36 Continuous phase controller

YH 20 35 85 120 180 250 360 Phase adjustment - Degrees - **YB** ON PC36 on OFF PC36 by-pass

SM24 Subsonic mono filter

WF 20 23 25 28 30 33 36 Frequency adjustment - Hz - **WB** ON SM24 on OFF SM24 by-pass

DSC1 Dynamic sub control

PG 0.0 0.4 1.0 3.0 5.0 7.5 8.5 9.0 Gain adjustment - dB - **PT** 1 2 3 4 5 6 7 8 Standard adj. Time delay adjustment

PRM3 Parametric equaliser

JF 35 50 70 90 130 190 200 Frequency adjustment - Hz - **JB** ON PRM3 on OFF PRM3 by-pass

JM ON Activates JX OFF 20 Hz ÷ 200 Hz **JL** -3 -6 -8 -9 +3 +6 +8 +9 Level adjustment - dB -

JX x 100 2 KHz ÷ 20 KHz x 10 200 Hz ÷ 2 KHz **JQ** 1.05 1.1 1.15 1.2 1.5 2.5 3.4 Q adjustment

• INCOLLARE QUI LA GUIDA RAPIDA DELLA MULTICHANNEL EXTENSION

• STICK THE MULTICHANNEL EXTENSION SHORT GUIDE HERE

• COLLER ICI LE RESUME DU MANUAL D'UTILISATION D'EXTENSION MULTICHANNEL

• KLEBEN SIE DIE MULTICHANNEL EXTENSION KURZ-BESCHREIBUNG HIER

MULTICHANNEL EXTENSIONS

HL12 Hi/Lo-pass stereo, 12 dB/Oct.

HL24 Lo-pass mono for Sub, 24 dB/Oct. and Hi-pass stereo, 12 dB/Oct.

LM24 Lo-pass mono, 24 dB/Oct.

BSA1 Line repeater and balancer

VRx1.500

Controls and functions

Leds

ON - Green led

It indicates the amplifier is on.

SAFETY - Red led

It indicates protection intervention: excessively high temperature or output anomalies (direct current, short circuit or dangerously low load impedance). Protection intervention stops the amplifier functioning. Switch the amplifier off; when anomaly is eliminated, switch the amplifier on again.

PEAK - Orange led

It is on when VRx amplifier is about to reach distortion threshold. It is useful to adjust inputs sensitivity.

Short guide

K1	<input type="checkbox"/> B	Balanced	Amp in: R only	IN
	<input type="checkbox"/> U	Unbalanced		Bal
K2	<input type="checkbox"/> OFF	Line Noise		LNS
	<input type="checkbox"/> ON	Suppressor		S
K3	<input type="checkbox"/> H	0.15 ÷ 1.5V	IN sensitivity range	LEVEL x3
	<input type="checkbox"/> L	0.5 ÷ 5V		
LM	<input type="checkbox"/> 4	6	Level	LEVEL
	<input type="checkbox"/> 2	10	Range K3	

Controls description

K1 - Bal/Unbal inputs switch.

K2 - LNS circuit **ON/OFF** switch for line noise suppression.

K3 - It selects **sensitivity range**.

LM - Amplifier input **sensitivity adjustment**.

Note: In case of installations with more amplifiers connected in cascade, we recommend to put **K2** onto **ON** in the first device (i.e. the one which receives the signal from the head unit), leaving it onto **OFF** in the others.

If disturbance persists, you can activate **LNS** anti-noise circuit also in the other amplifiers.

Controls under wooden strip

VRx

audison

2000 EDITION VRx1.500



VRx1.500

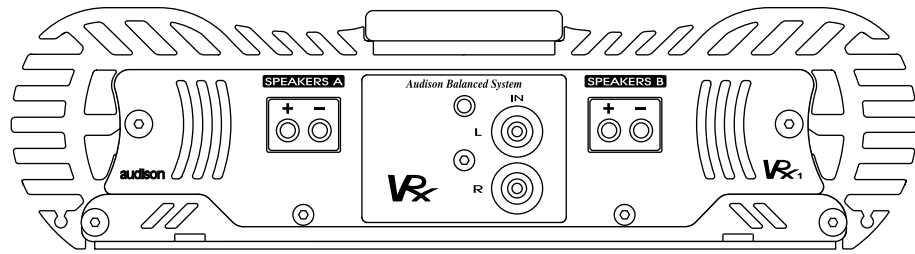

**Inputs panel with
multichannel
extensions:
HL12 - LM24
HL24 - BSA1**

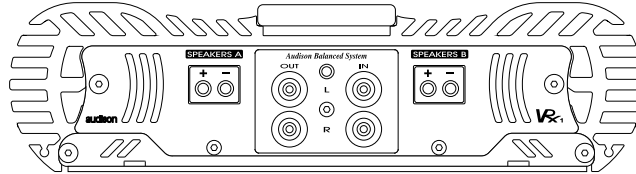

Technical features

POWER SUPPLY	11 ÷ 15 VDC
IDLING CURRENT	1.8 A
IDLING CURRENT WHEN OFF	< 0.04 mA
CONTINUOUS NOMINAL POWER Tol.: (+10%/-5%); 0.3% THD; 12 VDC	
1 ch on 4 Ohms500 W (RMS)
CONTINUOUS POWER Tol.: (+10%/-5%); 1% THD; 12,6 VDC	
1 ch on 4 Ohms560 W (RMS)
CONTINUOUS POWER Tol.: (+10%/-5%); 1% THD; 13,8 VDC	
1 ch on 4 Ohms560 W (RMS)
1 ch on 2 Ohms1080 W (RMS)
1 ch on 1 Ohm2000 W (RMS)
THD DISTORTION (1 kHz; 90% Nominal Power)	0.01 %
IMD DISTORTION (90% Nominal Power)	0.05 %
BANDWIDTH (-3dB; Nominal Power)	2 Hz ÷ 50 kHz
S/N RATIO (A weighed - 1 VRMS input)	100 dBA
REMOTE IN	7 ÷ 15 VDC
REMOTE OUT	12 VDC - 150 mA
INPUT SENSITIVITY (high)	0.15 ÷ 1.5 VRMS
INPUT SENSITIVITY (low)	0.50 ÷ 5.0 VRMS
INPUT IMPEDANCE	15 kOhms
LOAD IMPEDANCE	8 - 4 - 2 - 1 Ohm
SIZE (W x H x D) mm	240 x 64 x 432
SIZE (W x H x D) inches	9.4 x 2.5 x 17
INTERNAL FUSE	150A

ABSORBED CURRENT AT MAXIMUM MUSICAL POWER - EXTERNAL FUSE CHOICE

13,8V - 4 Ohm32 A
13,8V - 2 Ohm68 A
13,8V - 1 Ohm149 A

Measures were realised through a test-set consisting of Rohde & Schwarz UPD audio analyser, HP 6453A power supply (200A continuous) and 14F capacitive booster made with **audison cable Superfarad** capacitors.

Please always choose a fuse of equal or slightly higher value (max 10%) than indicated.

Note:

The use of MAC2 cooling system is strongly recommended when the amplifier is employed at full power with 2 Ohm or 1 Ohm loads.

VRx1.500 Block diagram

