

# **LR<sup>SR</sup><sub>x6</sub>** **Direct**

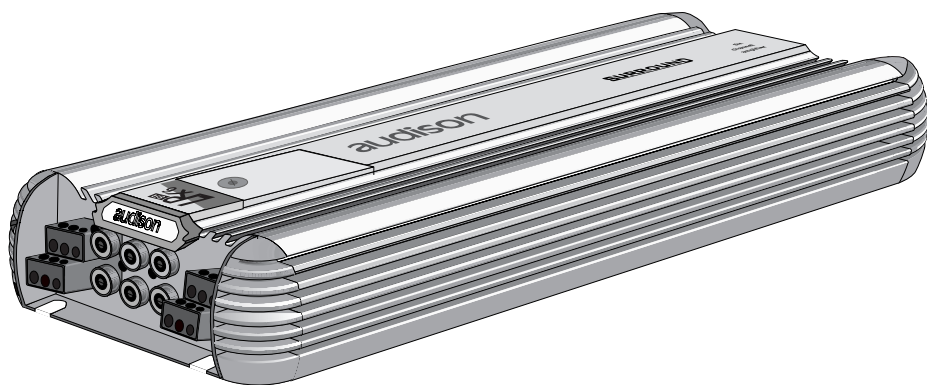

**CAR POWER AMPLIFIER**

**ENGLISH**

audison

## INTRODUCTION

**Audison** thanks you for preferring this product and compliments you on your choice since it was designed in order to insure outstanding musical and instrumental performances.

Before use instructions, please carefully read the safety norms you have to respect in order to avoid unpleasant inconveniences and to enjoy this product at best.

### Safety precautions

- The vehicle electric system must have 12VDC voltage with negative to ground. Make sure your car has it in order to avoid any damages to your amplifier and to the car itself.
- Suitably fix the amplifier with the screws given with it; pay utmost attention if you install it into the driver's compartment. Use extra fixing systems if you install it inside the bonnet. If the amplifier detaches itself while you are driving, it can severely damage people and other vehicles.
- Power supply cable must have mechanically resistant and self-extinguishing insulation. Its section has to comply with what is indicated in this manual. When placing it, avoid to press it against cutting parts or close to mechanical moving objects. Make sure it is suitably fixed all along its length. Put a clamping screw between positive and negative cable just close to the amplifier power supply terminal block.
- Put a fuse holder close to the battery positive terminal; connect one end of the power supply cable to it after connecting its other end to the amplifier. The fuse value must be the same as the amplifier built-in one. In case the cable supplies several amplifiers, the fuse value will have to be equal to the sum of the values of all other fuses in the system.
- For safer driving, we recommend to adjust volume not to drown external traffic sounds.
- **WARNING.** When the amplifier works in particularly hard conditions, it can reach 90°C (194°F). Make sure its temperature is safe before touching it.

### Functioning precautions

- Install the amplifier in locations where temperature is between 0°C (32°F) and 55°C (131°F).
- Don't connect -L and -R power outputs one to the other. If you use an external stereo crossover, make sure that its negative poles are not connected one to the other.
- When installing speakers and the cables that connect them, make sure that non-insulated parts don't touch the car chassis. If they do, the amplifier protection intervenes.
- Listening level calibration is made by adjusting the source volume up to 3/4 of its maximum level; then, adjust the amplifier levels until you can hear distortions.

### Maintenance precautions

- Periodically clean the amplifier avoiding to use aggressive solvents that might damage plastic or painted parts. Dampen a piece of cloth with water and soap, wring it and clean the amplifier with it. Then, clean the amplifier by using a piece of cloth dampened with water only; eventually clean it with a dry piece of cloth.

<b>Description</b> .....	p. 24
<b>In-Out panel</b>	
<i>Functions</i> .....	25
<b>Power supply panel</b>	
<i>Functions</i> .....	26
<i>Fuse replacement</i> .....	27
<b>Controls panel</b>	
<i>Functions and controls</i> .....	28
<b>Setting panel</b>	
<i>Functions</i> .....	30
<i>Subsonic filter activation</i> .....	30
<i>Subsonic filter cut-off frequency modification</i> .....	31
<i>VCA-VCA1D modules insertion</i> .....	31
<b>Technical features</b>	
<i>Size for fixing</i> .....	32
<i>LRx 6.SR Direct</i> .....	32
<b>Accessories</b>	
<i>VCRACK and VCRDK</i> .....	33
<i>CLK2 - LRx Cooling Kit</i> .....	34
<b>Configurations</b>	
<i>Block diagram</i> .....	35
<i>Controls panel diagram and subsonic filter switch</i> .....	36
<b>Configuration example</b>	
<i>Front+Rear+Center+Sub</i> .....	36
<b>Installation</b>	
<i>Logo rotation</i> .....	37
<i>Amplifier fixing</i> .....	38
<i>Electric connections</i> .....	38
<b>audison cable products for electric connections</b> .....	39
<b>audison measurement standards</b> .....	40

### **Audison LRx 6.SR Direct:**

Six channel car power amplifier characterised by excellent musical performances, small size and outstanding energy reserve.

Its PWM power supply stage is made with two pairs of 70A MOSFETs; it is stabilised and oversize. Input stage is provided with a special circuit (LNS) which allows the system disturbances rejection, reducing noise that is usually due to the vehicle electric parts (alternator, electronic injection, etc.), without altering musical signal quality.

Driver stage is characterised by a very linear circuitry; it has coupled differential transistors and an A Class complementary voltage amplifier. Power section has Darlington configuration with high gain and SOA (Safety Operation Area) BJT TO247. Thanks to its great capacity to supply current, this amplifier can easily drive even the hardest loads and satisfy whatever power needs. It can give 55W on Front, Rear and Center channels and 150W on sub with 4 Ohm load, 80W on Front, Rear and Center channels and 220W on sub at 2 Ohms in continuous mode. Differently from what occurs with other amplifiers, LRx 6.SR Direct is not blocked by protection systems immediately below these load values. Its exclusive "Overload Limiter" circuit allows it to go on working, limiting output power and pointing out how hard the applied load is by the "Limit" LED blinking.

Its big power reserve, its constant control at low frequencies and its exquisite timbre qualities make it an ideal amplifier to realise systems designed to attain outstanding musical features and very high sound pressures (SPL).

LRx 6.SR Direct has a bypass subsonic filter (24dB/Oct.) with adjustable frequency, pre-set at 20Hz.

In case LRx amplifiers are used in extremely difficult conditions (very low loads) or in installations where space is too narrow and their heat sink cooling is not enough, they can be employed together with CLK2 cooling system (optional). It is a system made of two units to apply onto the amplifier sides; each of them is provided with an electronically controlled fan that allows the amplifier thermal stabilisation (see "CLK2 – LRx Cooling Kit").

Protection includes:

- **RGP** (Resettable Ground Protection) circuit; in case a short circuit occurs between loudspeakers outputs and car chassis, it detects a high current flow in the pre-input ground and acts by putting the amplifier in stand-by, protecting its circuitry;
- a device against short circuits and against DC in the outputs, to protect loudspeakers;
- a device that detects the amplifier temperature excessive increase and stops its functioning until optimal conditions occur again.

Once the causes which implied protection circuits intervention have been checked and solved, the amplifier is reset by switching it off and on again.

The amplifier is also provided with another general protection which is insured by an internal strip fuse, very easy to reach.

### **Optional:**

The following devices are available upon request:

1 - Two kits for subwoofer volume remote control:

- VCRAK (analogue and specific for subwoofer);
  - VCRDK (digital; it can be used for master volume control or for level control of any ways in a multichannel system).
- 2 - CLK2 cooling system.

## FUNCTIONS

**1**

### FRONT/REAR/CENTER/SUB

Power outputs of the amplifier Front, Rear, Center and Sub channels. Connect the speakers cables to these outputs according to polarity. Terminal blocks accept cables up to 9 A.W.G. max (see "**audison cable** products for electric connections" as far as their size is concerned). We recommend the use of **audison cable** products.

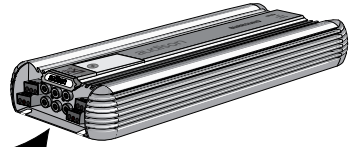

**2**

**PPS (Phantom Power Supply)**  
Power supply socket for **audison** external audio accessories.

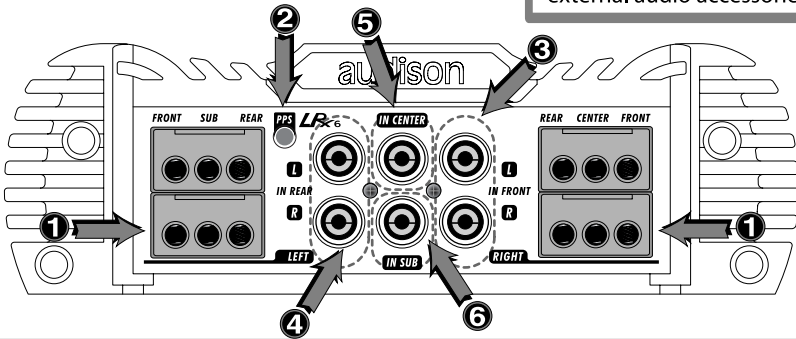

**3**

### IN FRONT

Left (L) and right (R) channels inputs of the amplifier Front system. Front preamplified outputs of a source (head unit, CD player, DAT, etc.) or of an external electronic crossover must be connected to them.

**4**

### IN REAR

Left (L) and right (R) channels inputs of the amplifier REAR system. Rear preamplified outputs of a source (head unit, CD player, DAT, etc.) or of an external electronic crossover must be connected to them.

**5**

### IN CENTER

Mono input for central channel. Center preamplified output of a surround processor (AC3, DTS, Dolby Pro Logic) must be connected to it.

**6**

### IN SUB

Mono input for sub. The source Sub preamplified output must be connected to it.

## FUNCTIONS

1

### REMOTE IN

Terminal to connect Remote cable, which comes from the source and which controls the amplifier switching on. Applied voltage must be between 7 and 15VDC.

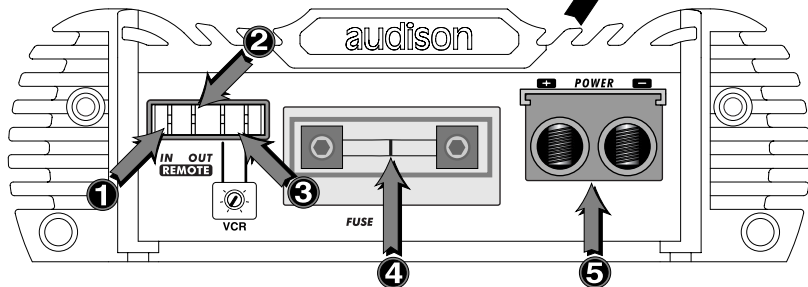

2

### REMOTE OUT

Terminal to repeat the switching on control (Remote IN) coming from the source. It is used to switch on another amplifier or device in the system simultaneously. Available voltage is the same as the one applied on Remote IN.

3

### VCR (optional kit)

Terminals to connect VCRA/VCRD adjuster included in sub output volume remote control kits (VCRAK/VCRDK).

4

### FUSE (60A)

Strip fuse. It insures the amplifier general protection. In case the fuse breaks down, please replace it by respecting its original value.

CAUTION: If you want to protect the system even more, please put a strip fuse onto the cable which connects the battery positive pole to the amplifier POWER (+) terminal block (see "Electric connections").

5

### POWER

Terminal blocks for the amplifier power supply cable connection. Connect positive and negative poles according to indicated polarities. Holes have 8mm diameter and accept cables up to 3 A.W.G. max. In order to get the best current transfer, please use power supply cables with as big a section as possible. **audison cable** catalogue offers you a complete range of such products which can satisfy whatever demands; you can also find **Maincrimp** terminals in it. We strongly recommend their use because they contain the cable non protected end and allow the terminal block to fasten all its useful section.

## FUSE REPLACEMENT

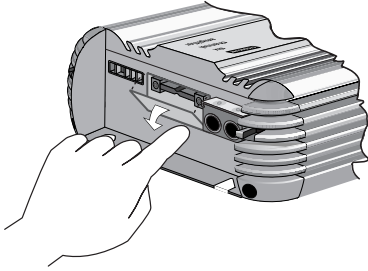

**1** - Open the transparent cover by pushing the two teeth in its lowest corners to the direction indicated by the arrows.

**2** - Remove the screws which fasten the fuse to eliminate pieces of the broken one; prevent them from going into the device.

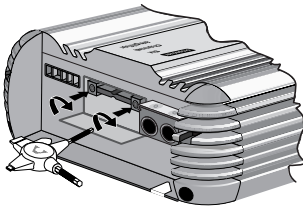
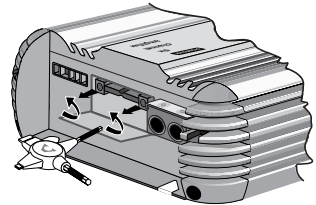

**3** - Check the value of the new fuse to assemble, then fix it by gradually and alternately fastening the two screws. This will avoid voltage drops along the line and will make the device perfect functioning easier.

**4** - Close the transparent cover.

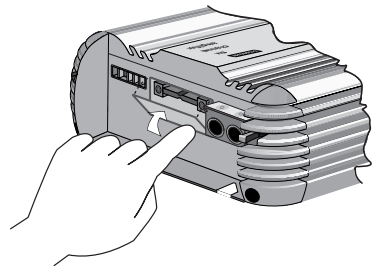

# CONTROLS PANEL

## FUNCTIONS AND CONTROLS

1

### LIMIT (orange LED)

It indicates the Overload Limiter circuit is on.

#### Caution:

When this led is on (although sporadically), it means the applied load is a hard one. The activation of Overload Limiter circuit (output power limiter) will anyway allow the amplifier to function without distortions. In case Overload Limiter gets on too frequently (at every power peak), you will need to check if there are any failures or a too hard load (that's to say impedance is about 50% lower than the minimum recommended one). The amplifier can go on functioning in these conditions but power will inevitably decrease.

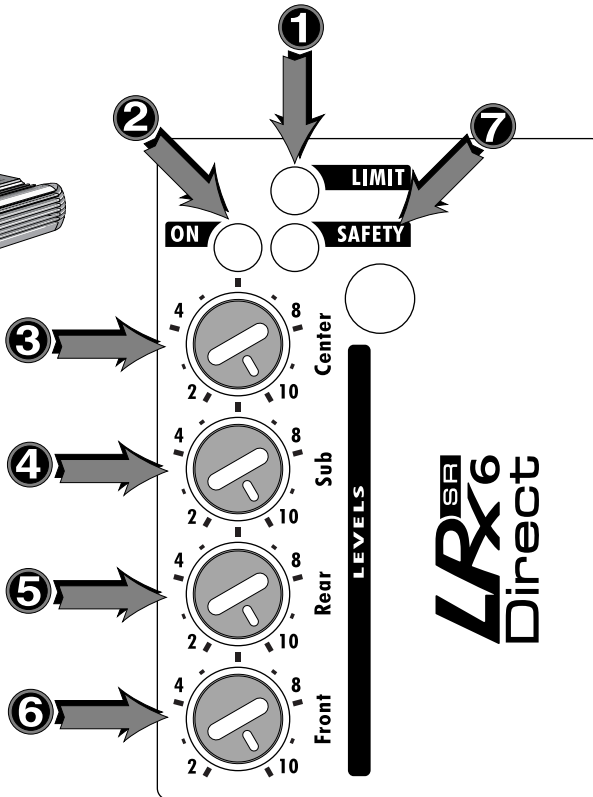
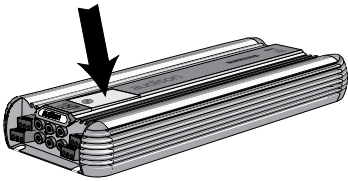

2

### ON (green LED)

It indicates the amplifier is on.

3

### CENTER (Level)

It adjusts the amplifier Center channel input sensitivity and sets its output level.



**4**

### **SUB (Level)**

It adjusts the amplifier Sub channel input sensitivity and sets its output level.

**5**

### **REAR (Level)**

It adjusts the amplifier Rear channels input sensitivity and sets its output level.

**6**

### **FRONT (Level)**

It adjusts the amplifier Front channels input sensitivity and sets its output level.

**7**

### **SAFETY (red LED)**

It indicates that the amplifier protection circuits are on. In order for the amplifier to work again, you need to switch the system off and then on after 10 seconds at least. We recommend to check all connections before switching the amplifier on again.

**If LED stays on, please contact Audison authorised after sale centres.**

# SETTING PANEL

## FUNCTIONS

It permits to reach the resistors to set subsonic filter cut-off frequency, the switch which activates subsonic filter (**SUBSONIC**) and to insert VCA modules for the subwoofer volume remote control.

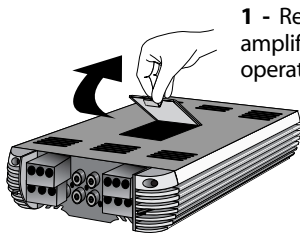
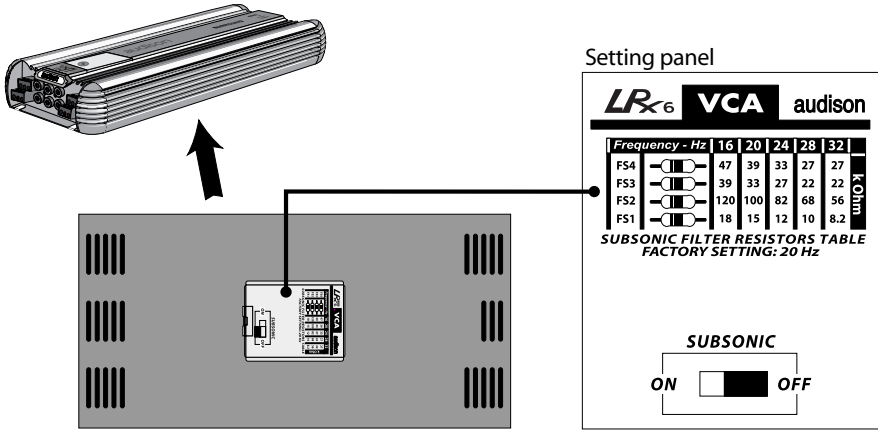

1 - Remove the setting panel in the amplifier bottom in order to carry out operations.

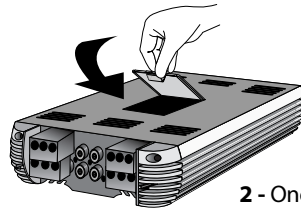

2 - Once operations have been carried out, please close the setting panel.

## SUBSONIC FILTER ACTIVATION

Subsonic filter is activated through **SUBSONIC** switch under the setting panel.

- **SUBSONIC** switch permits to eliminate subsonic frequencies; these sounds cannot be heard by human ears but cause useless and damaging stress to amplifier and speakers. When it is on ON, frequencies below the chosen cut-off one are eliminated.

Subsonic filter cut-off frequency can be adjusted through 4 Hz steps; this occurs by replacing the special resistors located into a socket which can be reached through the setting panel in the amplifier bottom. The amplifier is given with **20 Hz** cut-off frequency.

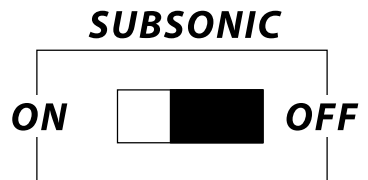

## SUBSONIC FILTER CUT-OFF FREQUENCY MODIFICATION

Subsonic filter is pre-adjusted at 20 Hz. In order to modify this value, please act according to what follows.

### Procedure:



Frequency - Hz	16	20	24	28	32		
FS4		47	39	33	27	27	kOhm
FS3		39	33	27	22	22	
FS2		120	100	82	68	56	
FS1		18	15	12	10	8.2	

**SUBSONIC FILTER RESISTORS TABLE**  
FACTORY SETTING: 20 Hz

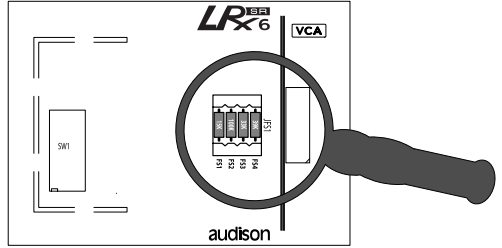

Replace FS1, FS2, FS3, FS4 resistors according to the values in the setting panel table.

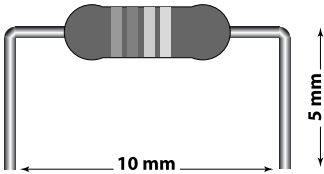

**Remark:** Cut the new resistors rheophores according to the size in the picture.

## VCA-VCA1D MODULES INSERTION

LRx 6.SR Direct can accept one of the two optional kits which allow the subwoofer volume remote control: VCRAK or VCRDK.

These kits have a specific module, VCA or VCA1D, to insert into the amplifier through the setting panel.

### Installation:

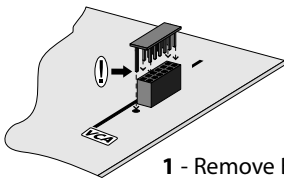

1 - Remove BYP12 bridge.

! - Insertion key. It prevents the module from being inserted in the wrong way.

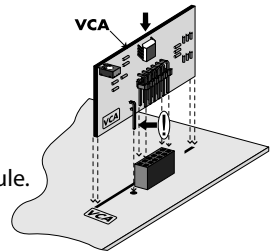

2 - Insert VCA/VCA1D module.

# TECHNICAL FEATURES

## SIZE FOR FIXING

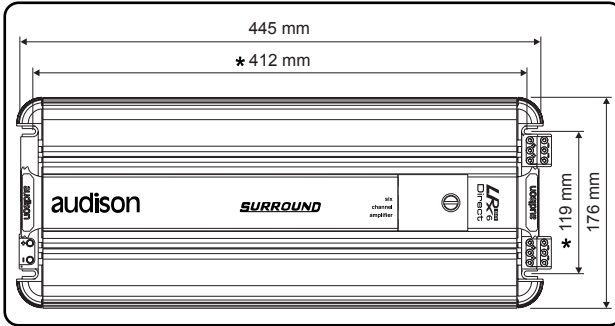

\* Drilling dimensions for fixing

## LRx 6.SR Direct

### POWER SUPPLY

Voltage:..... 11 ÷ 15 VDC  
 Idling current: ..... 1.1 A  
 Idling current when off: ..... 0.02 mA

Consumption @ 13.8 VDC

(Max Musical Power):

- A config. (see Output Power): ..... 34.5 A  
 - B config. (see Output Power): ..... 51 A  
 - C config. (see Output Power): ..... 60.5 A

### AMPLIFIER STAGE

Distortion – THD (1kHz):..... 0.009 %  
 Bandwidth (-3dB): ..... 4 Hz ÷ 85 kHz  
 S/N ratio(A weighed @ 1V): ..... 105 dB  
 Damping factor (1 kHz, 4 Ohms):..... 240  
 Input sensitivity: ..... 0.2 ÷ 5 VRMS  
 Input impedance: ..... 15 kOhms  
 Load impedance:  
 - Front/Rear/Center/Sub: ..... 4 - 2 Ohms

Nominal output power (RMS)

**NP** @ 12VDC;THD 0.3%: .....  
 ..... 55W x 5 (4 Ohms) + 150W x 1 (4 Ohms)

Output power (RMS) @ 13.8 VDC;THD 1%

- A config.: 55W x 5 (4 Ohms) + 150W x 1 (4 Ohms)  
 - B config.: 80W x 5 (2 Ohms) + 150W x 1 (4 Ohms)  
 - C config.: 80W x 5 (2 Ohms) + 220W x 1 (2 Ohms)

### FILTERS/INPUTS

Subsonic: Bypass/ 24dB/Oct. Hi-Pass, 16÷32 Hz  
 (pre-set at 20 Hz)  
 Inputs: .. IN Front - IN Rear - IN Center - IN Sub

### OTHER FUNCTIONS

Remote IN:..... 7 ÷ 15 VDC – 1 mA  
 Remote OUT (3 Outs): ..... 12 VDC – 10 mA  
 Auxiliary power supply (PPS): ±12 VDC – 300 mA  
 IN VCR (SUB volume) VCA/VCA1D attenuation:  
 100 dB  
 Fuse: ..... 60 A

**MAX SIZE** (L x H x D):..... 176 x 56 x 445 mm

**WEIGHT:** ..... 3.9 kg

## VCRAK and VCRDK

LRx 6.SR Direct can accept one of the optional kits that allow the subwoofer volume remote control. VCRAK is analogic and special for sub; VCRDK is digital and can be used for master volume control or for level control of any ways in a multichannel system.

These kits are available as accessories and consist of three elements:

- 1) Volume adjuster (VCRA/VCRD);
- 2) VCA/VCA1D module to put inside the amplifiers;
- 3) Wire to connect VCRA/VCRD adjusters to the proper sockets in the amplifier rear panel and to the car lights switch, in order to light it up.

Install VCRA/VCRD adjusters in a place you can easily and comfortably reach, according to the following connection diagram.

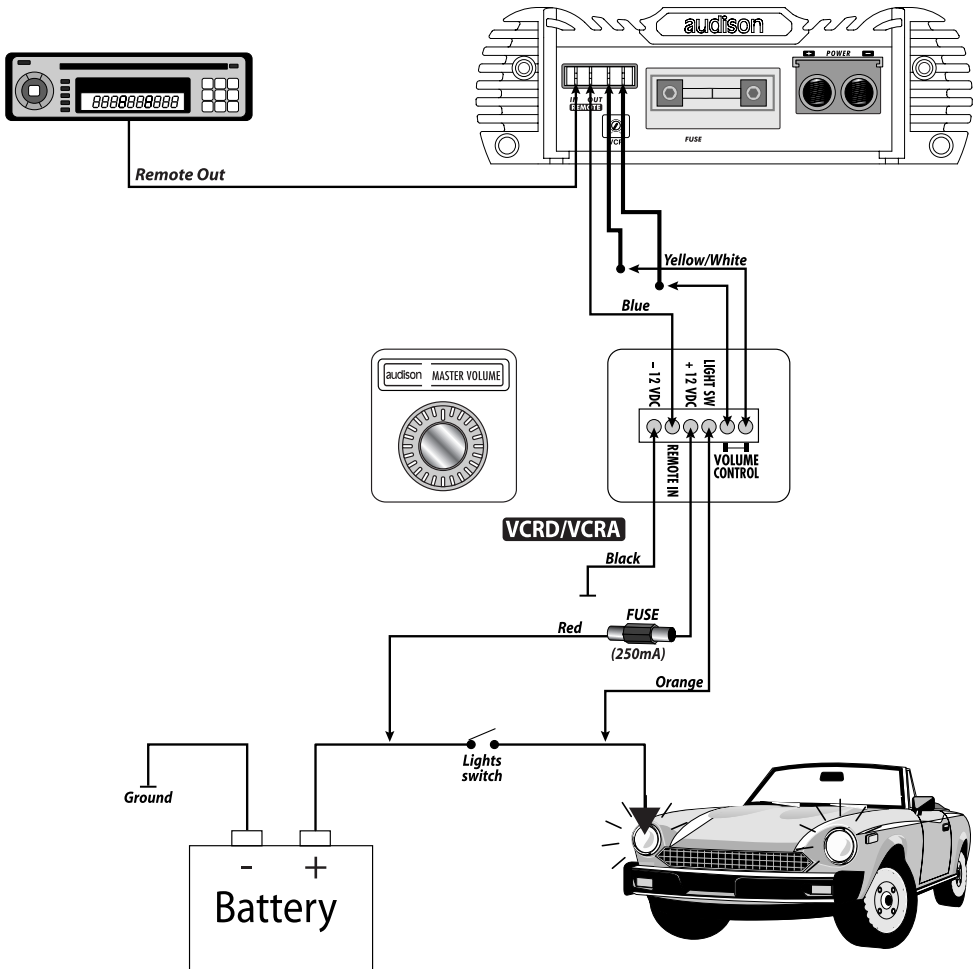

## CLK2 – LRx Cooling Kit

This cooling system is specially designed to provide LRx amplifiers with the right working temperature. CLK2 should be used when LRx amplifiers work in extremely hard conditions (very low loads) or in installations where space is too narrow and heat sink cooling is not enough. It consists of two units to apply onto the amplifier sides; each of them is provided with an electronically controlled fan. Its intervention depends on a thermal sensor that starts the system as soon as LRx heat sink reaches 45°C. The same sensor is connected to a special circuit which controls the two fans speed progressive increase when temperature increases, too.

Air flux constant control allows the amplifier very good thermal stabilization and limits noise.

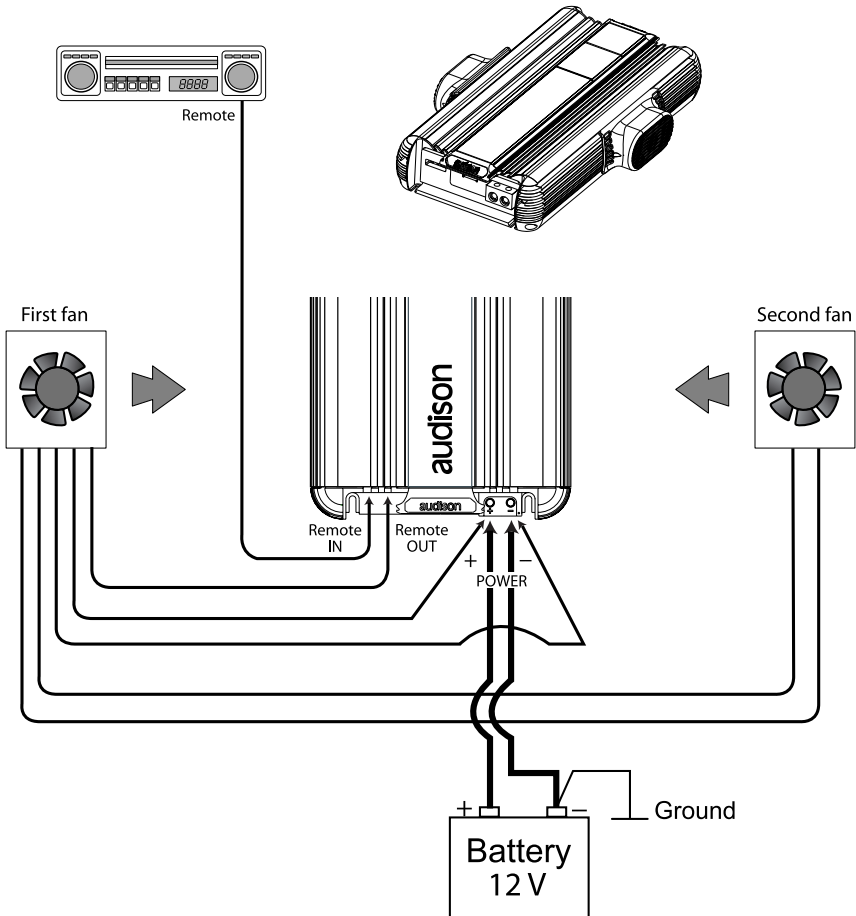

# CONFIGURATIONS

## BLOCK DIAGRAM

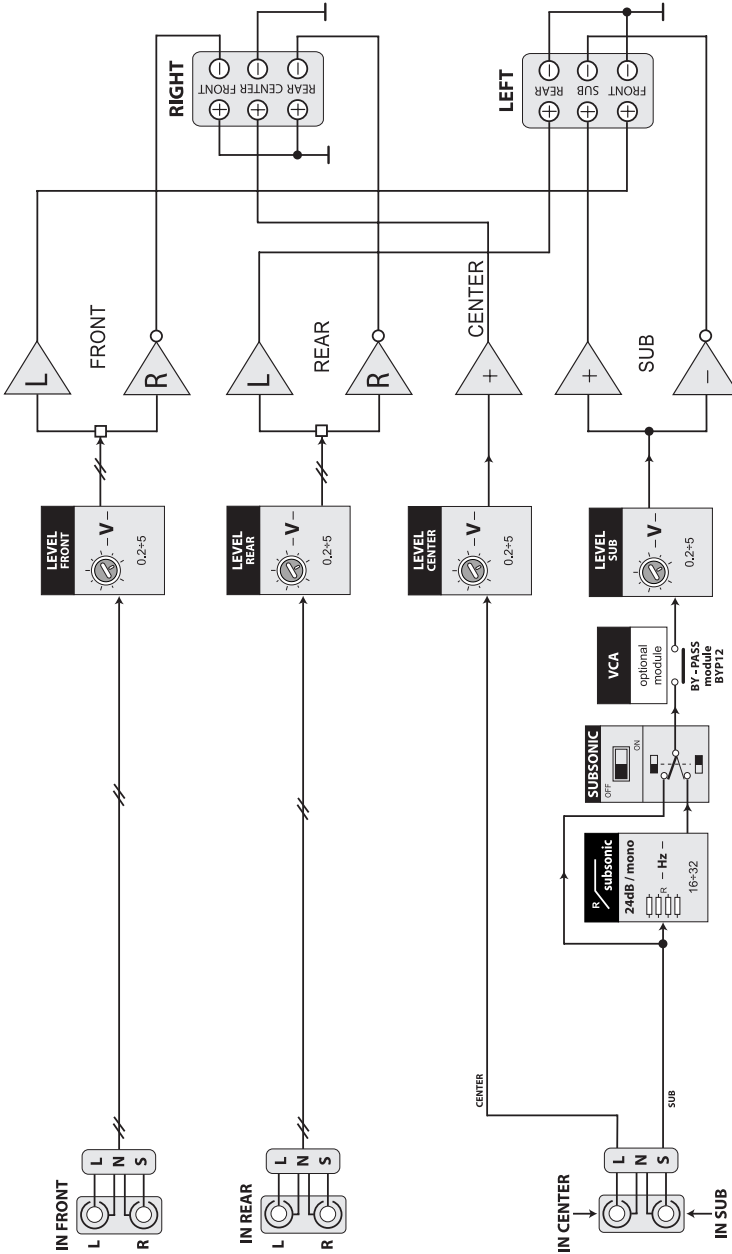

# CONFIGURATIONS

## CONTROLS PANEL DIAGRAM AND SUBSONIC FILTER SWITCH

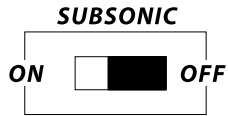
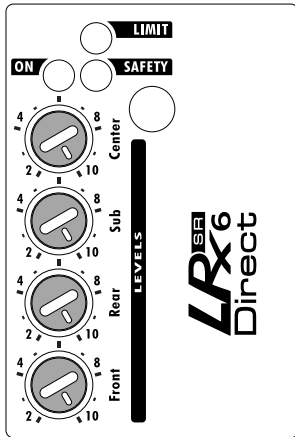

## CONFIGURATION EXAMPLE

### FRONT+REAR+CENTER+SUB

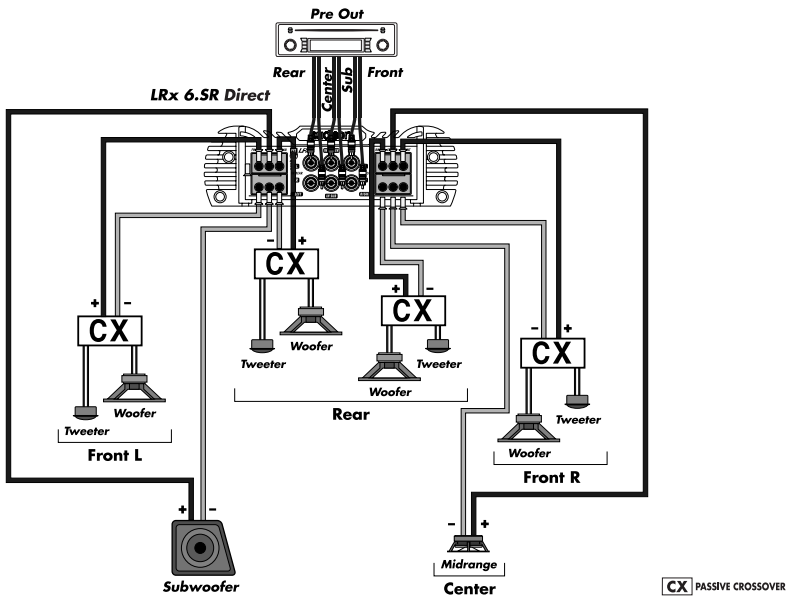



# INSTALLATION

## LOGO ROTATION

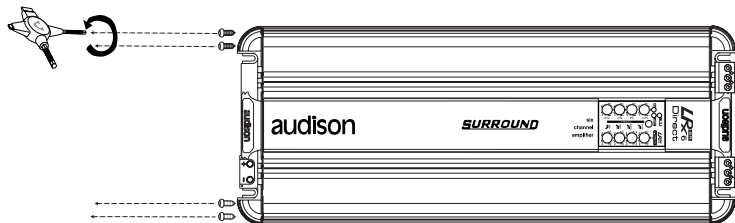

1 - Remove the transparent cover which protects controls and then the 4 screws which block the metal plate by using multispanner.

2 - Remove the plate without damaging the silkscreen printed panel which will have to stay on. We suggest that you seize both plate grips with your hands and pull them by blocking the silkscreen printed panel with your fingers against the amplifier chassis at the same time. This will permit to remove the plate from the panel without damages.

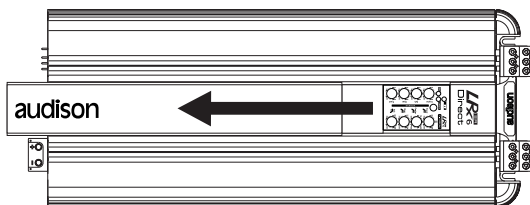
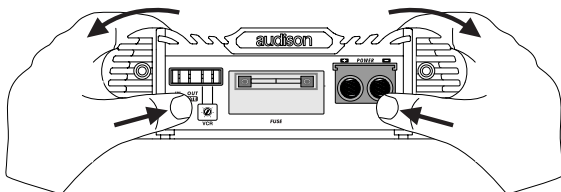

3 - Remove the strip with **audison** logo.

4 - Put the strip back again after turning it, so that **audison** logo is upside down.

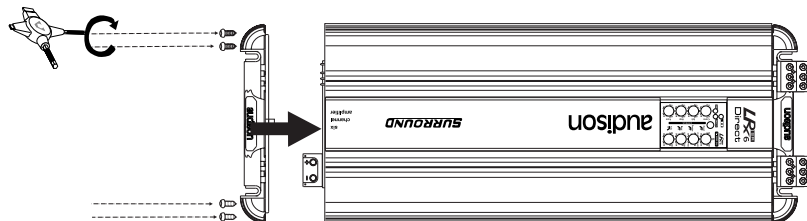
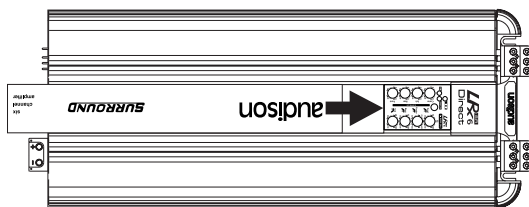

5 - Mount the plate back by fixing it through the screws; then, re-assemble the transparent cover which protects controls.

# INSTALLATION

## AMPLIFIER FIXING

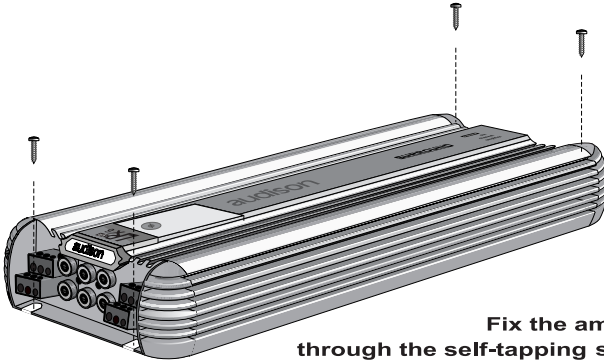

Fix the amplifier through the self-tapping screws (4.2 x 16) given with it.

## COLLEGAMENTI ELETTRICI

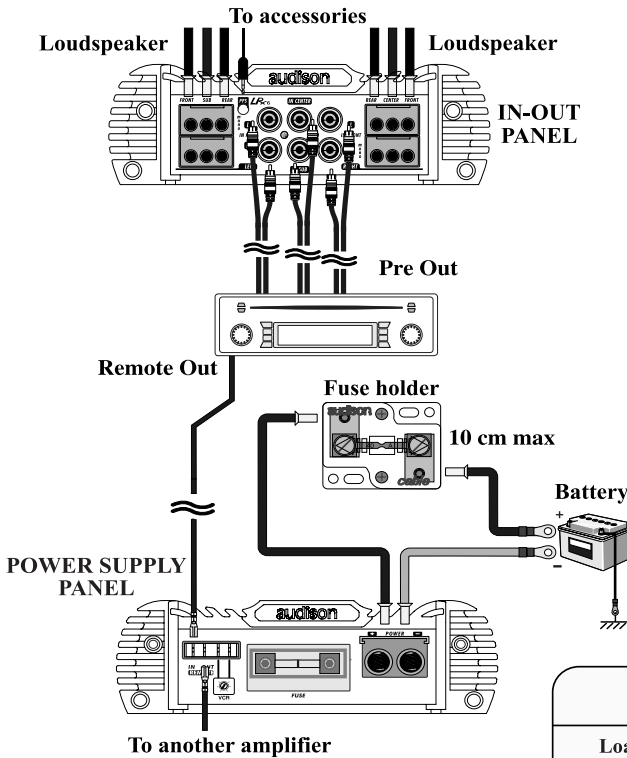

### CAUTION

For the system safer protection, we recommend the use of a strip fuse on the cable that connects the battery positive pole to the amplifier POWER (+) terminal block. This fuse has to be installed about 10 cm far from the battery; its value will have to be equal or slightly higher (+10% approx.) than consumption @13.8 VDC, according to the different configurations (see "Technical features").

It will have to be equal to the sum of the values of all fuses in case system consists of several amplifiers or in case amplifiers have several fuses.

**LRx 6.SR Direct FUSE: 60A**

POWER SUPPLY CABLE SIZE Length: 4/5 m				
Load	4 Ohm		2 Ohm	
Unit of measure	mm <sup>2</sup>	A.W.G.	mm <sup>2</sup>	A.W.G.
<b>LRx 6.SR Direct</b>	8,6	7	15,2	5

# INSTALLATION

## audison cable PRODUCTS FOR ELECTRIC CONNECTIONS



 **MAINCRIMP**

**audison cable**



**RING TERMINALS** 

### RECOMMENDED POWER SUPPLY CABLES

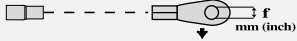
*Cable must be chosen according to its length and to the system total power.*

POWER SUPPLY TERMINAL BLOCKS		CABLES		BATTERY + AND GROUND	
					
4 Ohms	MAINCRIMP 8	For 7 A.W.G.	POWERFLOW 7 (red and black)	PR 62.19 R&B	RB 6.45.1G f = 6 (.24) RB 8.45.1G f = 8 (.31)
2 Ohms	MAINCRIMP 8	For 5 A.W.G.	MAINPOWER 5 (red and black)	PR 80.24 R&B	RB 6.58.1G f = 6 (.24) RB 8.58.1G f = 8 (.34)

### RECOMMENDED SPEAKERS CABLES

SPEAKERS TERMINAL BLOCKS	CABLE
	
MAINCRIMP 14	5x096/20 (2x16 A.W.G.) + 1x093/20 (2x14 A.W.G.)
MAINCRIMP 14	5x093/20 (2x14 A.W.G.) + 1x092/20 (2x12 A.W.G.)

### RECOMMENDED SIGNAL CABLES

*BEST series PIN-RCA / PIN-RCA extensions are available in the following sizes*

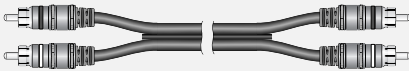

BS 50	cm 50 (19.68 inch)	BS 300	cm 300 (118.11 inch)
BS 100	cm 100 (39.37 inch)	BS 400	cm 400 (157.48 inch)
BS 150	cm 150 (59.05 inch)	BS 450	cm 450 (177.16 inch)
BS 200	cm 200 (78.74 inch)	BS 500	cm 500 (196.85 inch)
		BS 600	cm 600 (236.22 inch)

## **Standard di misura Audison**

*(Potenze misurate secondo lo standard **audison** edizione 1998)*

- 12VDC e 13.8VDC;
- 1 kHz o frequenza di taglio del crossover;
- 0.3% THD @ potenza nominale; 1% THD @ potenza continua;
- Tolleranza: +10%, - 5%;
- Potenza continua misurata applicando una tensione RMS su carico resistivo;
- Potenza nominale misurata utilizzando una batteria da 12V DC con un carico di 4 Ohm e tutti i canali in funzione.

## **Audison measurement standards**

*(Power measures taken according to **audison** standard, 1998 edition)*

- 12VDC and 13.8VDC;
- 1 kHz or crossover cut-off frequency;
- 0.3% THD @ nominal power; 1% THD @ continuous power;
- Tolerance: +10%; -5%;
- Continuous power given by RMS Voltage measured on resistive load;
- The nominal power of the amplifier is measured upon a battery voltage of 12 Volts with a 4 Ohm load and with all channels in function.

