

W 40

Sd:	50 cm ²
Vas:	1.35 l
Cms:	3.8e-04 m/N
Cas:	9.7e-09 m/N
Mmd:	8,41 gr
Mms:	8,45 gr
Rms:	0.79 Ns/m
Fs:	88 Hz
Bl:	3.92 N/A
Re:	2.70 ohm
Le:	0.49 mH
Qms:	5.90
Qes:	0.83
Qts:	0.72
V/C l:	19.00 mm
Xmax:	14.00 mm
Pmax:	40 W
dBSpl:	88 dB

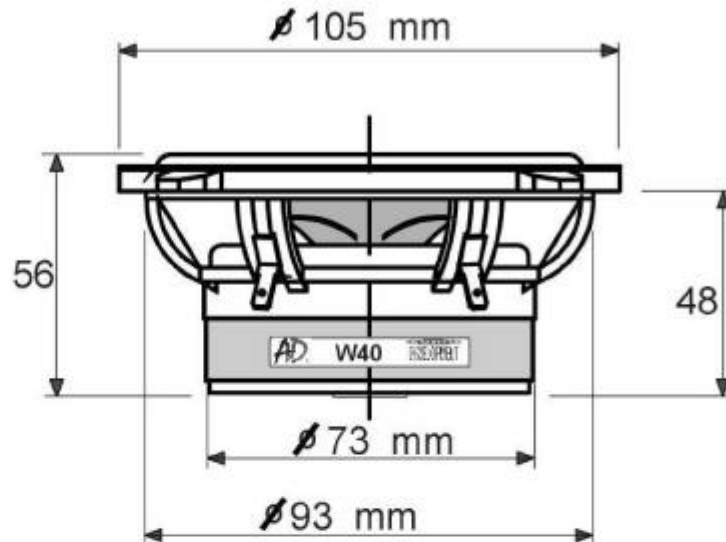

W 40 IMPEDANCE

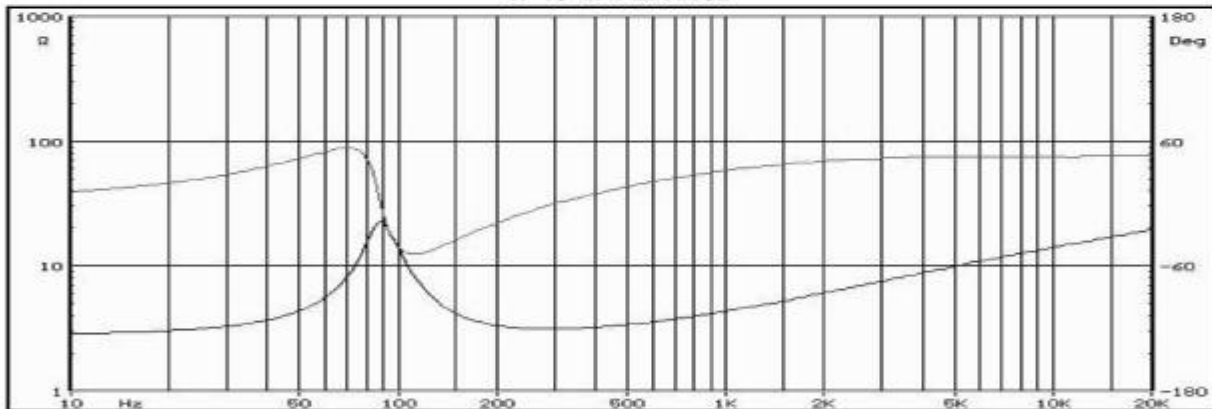

DESIGN FEATURES

- CONE: Double layer fibreglass with rubber suspension.
- VOICE COIL: Pure copper wire on aluminium former (\varnothing 26 mm).
- BASKET: Owner's design, a PPO chassis injected with fibreglass, in order to low down undesired distortions.
- DUST COVER: ABS, glued directly to the V/C former, with calibrated weight and dimensions in order to reach the desired Mms.

The 10 cm midwoofer of AD is the answer for the request of such a small diameter woofer; a complete, as possible, frequency response on the woofer side, without melting and confusing the mid side.

As the others of the same line, the W 40 is a real "all purpose", good each time quality is the target.

Phase and impedance curves are measured after 20 hours burn-in at 20 W RMS, so are the T / S parameters. Due to the continue research and development, these information are subject to change without notice.