

# T 100 R

Re:	3.00 ohm
Le:	0.035 mH
Qms:	2,25
Qes:	-
Qts:	0.62
Freq. Resp.	1500 – 20000 Hz
Xmax:	-
Pmax	100.0 W 2,0 KHz
dBSpl:	90.0 dB

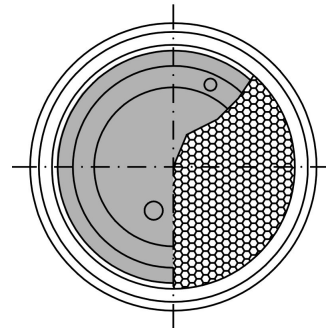
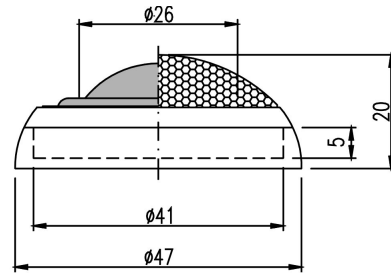

## DESIGN FEATURES

- DOME: 26 mm diameter silk dome, ported and balanced on the suspension.
- VOICE COIL: Pure copper on aluminum former (Ø 25 mm) Ferrofluid cooled
- MAGNETIC CIRCUITATION: High thermal stability Neodimium, magnetized with an internal procedure.
- MOUNTING SYSTEM: Tri-mount with adaptors, for external, internal or baffle usage.

Direct evolution of the T 100, it differs for the superb working on the dome and the chamber beside it, which permits the T100 R to work tuned with a reflex port, extending the frequency response to 1.500 Hz, without increasing the third harmonic distortion.

## T 100 R IMPEDANCE

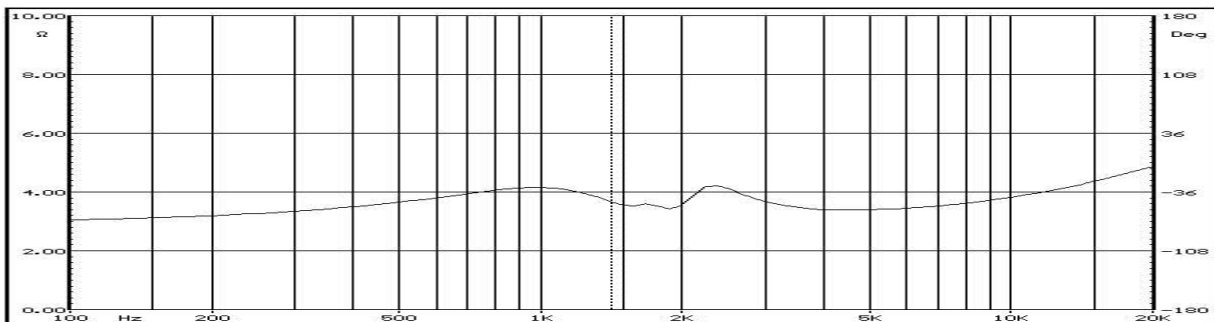

## T 100 R FREQUENCY RESPONSE

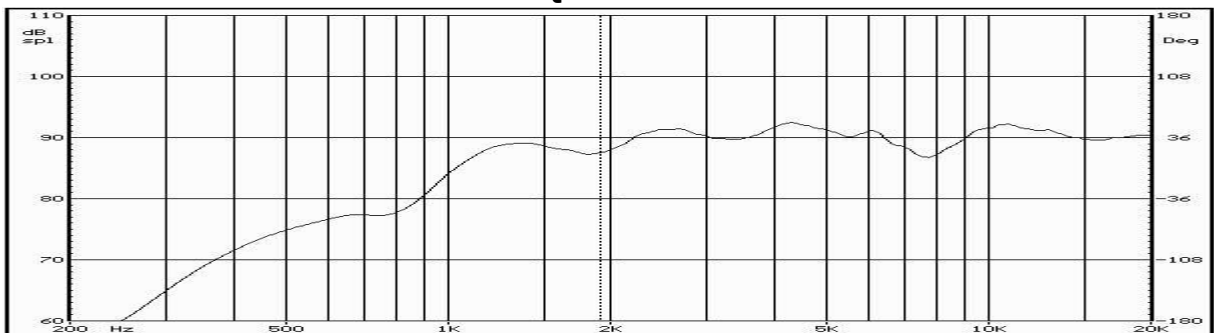

Due to the continue research and development, these information are subject to change without notice.