

M 40 NEO

Sd:	55.3 cm ²
Vas:	1.33 l
Cms:	3.8e-04 m/N
Cas:	9.5e-09 m ⁵ /N
Zm:	10.39 ohm
Mms:	5.76 g
Rms:	1.07 Ns/m
Fs:	108.0 Hz
Bl:	3.20 N/A
Re:	3.0 ohm
Le:	0.31 mH
Qms:	3.67
Qes:	1.14
Qts:	0.87
V/C l:	12.0 mm
Xmax:	8.0 mm
Pmax:	40 W
dBSpl:	87.5 dB

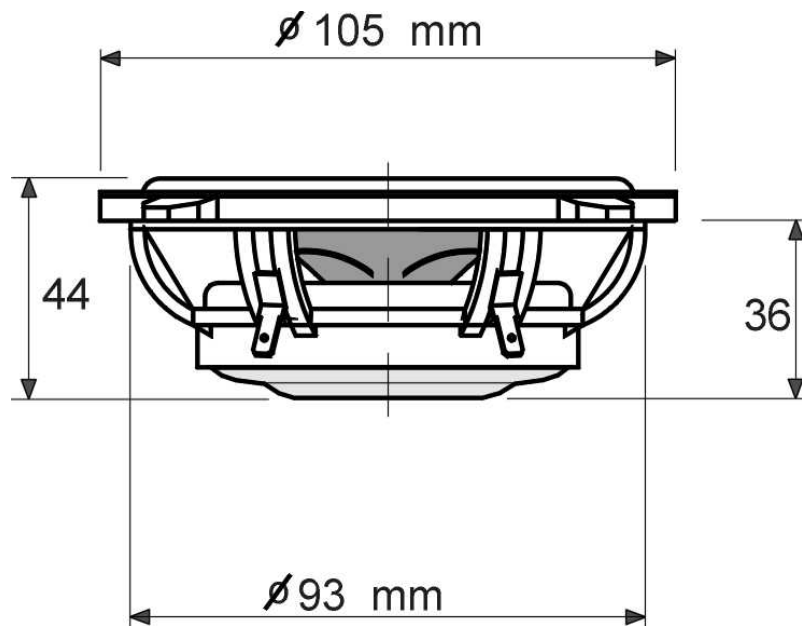

IMPEDANCE

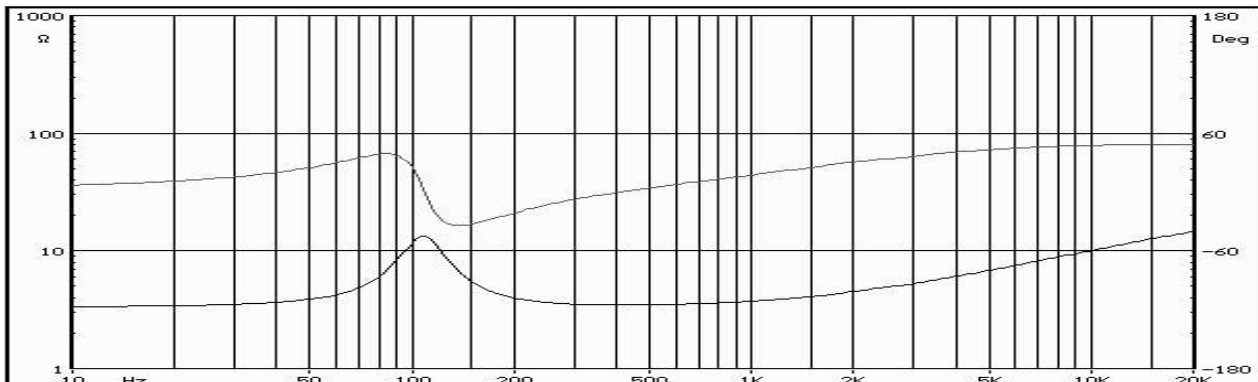

DESIGN FEATURES

- CONE: Double layer fiberglass with rubber suspension.
- VOICE COIL: Pure copper wire on aluminum former (∅ 26 mm). High temperature stable neodymium magnet, internally magnetized with a proprietary procedure.
- BASKET: Owner's design, a PPO chassis injected with fiberglass, in order to low down undesired distortions.
- DUST COVER: : Fabric. Material and dimension studied to obtain the right coupling with the cone controlling the polar dispersion.

Design and development of mid-frequency transducers is heavily conditioned by the design of the dedicated crossover, because for AD this part of the musical reproduction is the most delicate and at the same time difficult to obtain in a three way front system . Our listening panels have directed our research to the choice of the "filler driver", as described on the data-sheet of the X 1 FD.

Phase and impedance curves are measured after 20 hours burn-in at 20 W RMS, so are the T / S parameters.
Due to the continue research and development, these information are subject to change without notice.