

VIPERA F8

Le:	1.35 mH
Re:	3.2 ohm
Fs:	37 Hz
Qms:	3.85
Qts:	0.42
Vas:	12 l
Bl:	11 N/A
Ferq.Resp:	30-500 Hz

Sd:	188 cm²
Xmax:	36 mm
Pmax:	400 W
dBSpl:	88 dB

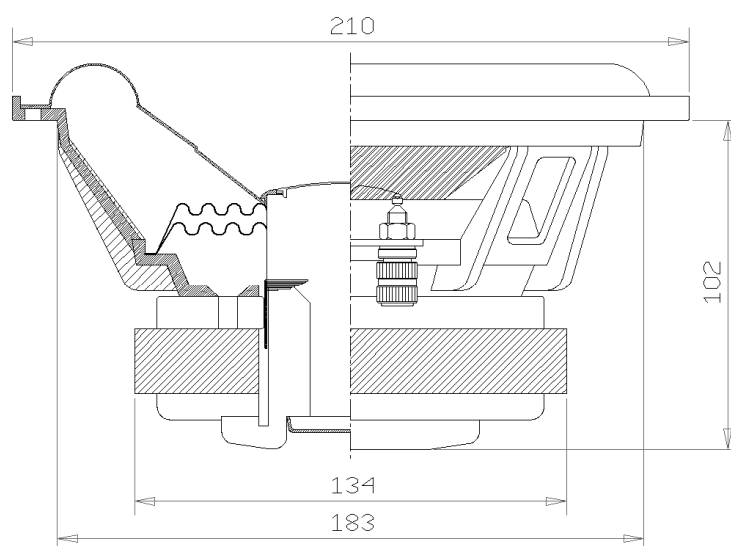

VIPERA F8 PHASE/IMPEDANCE

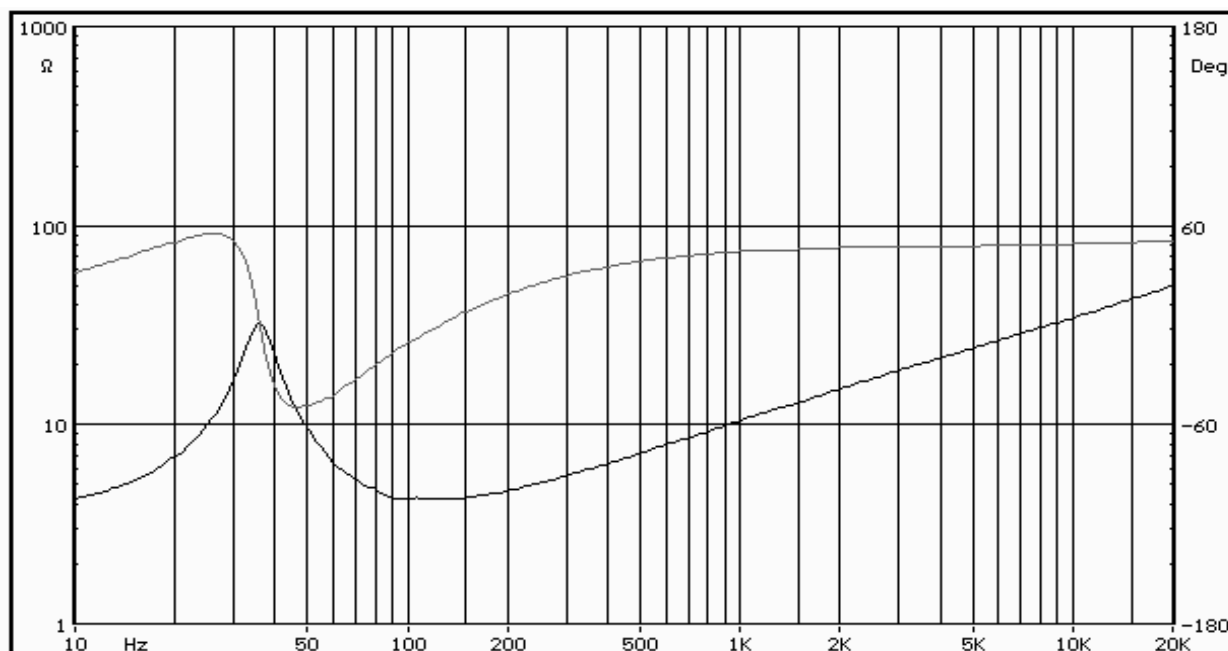

TECHNICAL FEATURES

- CONE: Paper / Fiberglass in double coat treated for min. cone flexing and max. dumping, treated with an internal procedure in order to restore the piston movement.
- SUSPENSION: injection rubber / SPIDER: No.2pcs. in conex
- VOICE COIL: OFC voice coil on alu-former (\varnothing 55 mm). Vented pole for forced air cooling .
- BASKET, MAGNET: multi reinforced Aluminum. Magnet with ferrite ring.

This subwoofer has been created to satisfy the SPL fans without compromising the high quality. It can extend to the lowest in few liters; it is suitable to bass reflex alignments or band pass.

Note: It can bear high accelerations without losing its shape.

Phase and Impedance curves are measured after 20 hour of use at 80 W RMS, so are the T/S parameters. Due to the continue research and development, these information are subject to change without notice.

Laboratorio Audio s.n.c. Via del Progresso 26/A Castelgomberto (VI) AD audio development.