

## High Efficiency Power Amplifier Module

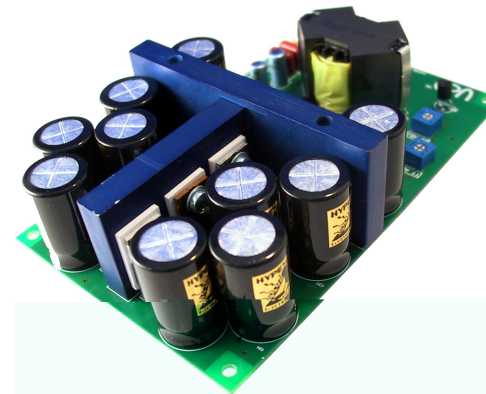

### Highlights

- Flat, fully load-independent frequency response
- Low output impedance
- Very low, frequency-independent THD
- Very low noise
- Fully passive loop control
- Consistent top performer in listening trials

### Features

- Runs on unregulated +/- rails
- Pop-free start and stop control
- Differential audio input
- Overcurrent and overvoltage protection
- Weight: 280gms

### Description

The UcD700™ (HG version) amplifier module is a self-contained high-performance class D amplifier intended for a wide range of audio applications, ranging from Public Address systems to ultrahigh-fidelity replay systems for studio and home use. Chief distinguishing features are flat frequency response irrespective of load impedance, nearly frequency-independent distortion behaviour and very low radiated and conducted EMI. Control is based on a phase-shift controlled self-oscillating loop taking feedback only at the speaker output.

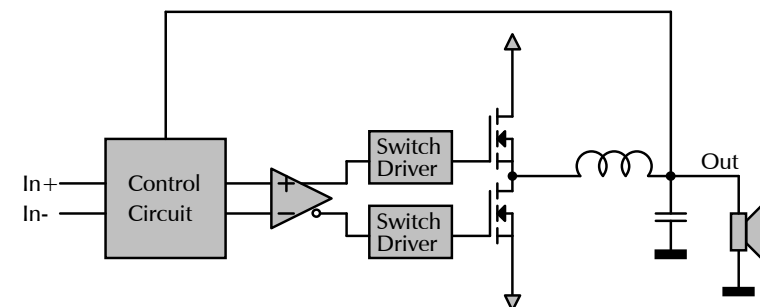

Fig 1. UcD diagram

### Package contents

Check your package for the following items:

- UcD700HG unit
- 6 x Faston crimp connectors
- Flatcable
- 2 x jumper
- 2 x bolt M4x10mm

### Connection Diagram

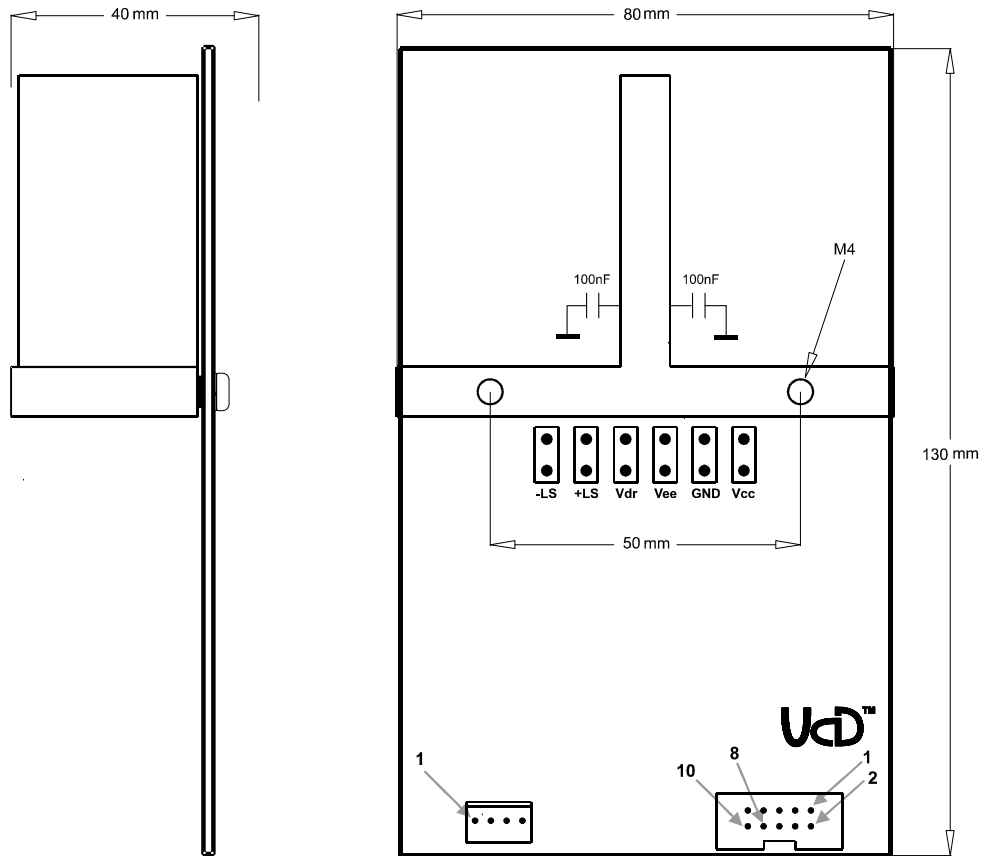

Fig 2. UcD700HG dimensions

Hypex Electronics BV  
 Kattegat 8  
 9723 JP Groningen  
 The Netherlands

Phone: +31 50 526 4993  
 Fax: +31 50 525 4591

Email: [info@hypex.nl](mailto:info@hypex.nl) [support@hypex.nl](mailto:support@hypex.nl)  
<http://www.hypex.nl>

Also available from Hypex Electronics:



### UcD700 Supply

#### Features

- Audiophile 100V Slit-Foil capacitors
- DC-protection
- On-board fuses
- Dual high-speed rectifier bridges
- Fits in a 2HE housing when mounted on its side.

#### Applications

- UcD700 mono or stereo applications
- Monitor loudspeakers for recording and mastering studios
- Audiophile power amplifiers for professional and consumer use
- Public Address systems
- Home theatre systems
- Active loudspeakers



## UcD180™ HG-series

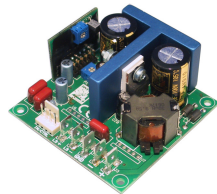

## UcD400™ HG-series

### Signal Connectors Specification

Pin (4-pin MOLEX® KK®)	Pin (10-pin Flatcable header)	Function
1	4	Non inverting Audio Input
2	2, 7, 8	GND
3	3	Inverting Audio Input
4	5	ON/OFF control
	1	DC Protect
	10	+12V (*)
	9	-12V (*)

### Power Connectors Specification

Pin FASTON® tab	Function
-LS	Loudspeaker output (cold)
+LS	Loudspeaker output (hot)
Vee	Negative power supply connection
Vdr	Driver supply connection ( <b>referred to Vee</b> ) (*)
GND	Power supply ground connection
Vcc	Positive power supply connection

\* These voltages have to be applied to the module externally. The UcD700HG does not provide these voltages. More information regarding the supply can be downloaded from our website: [www.hypex.nl](http://www.hypex.nl).

All supply voltages need to come up simultaneously. Removing or shorting supply voltages while the amplifier is running may damage the device.

### Cabling

The Faston crimp connectors included in this package are suitable for a maximum wire gauge of 13 AWG (2.5mm<sup>2</sup>). Make sure these connectors are crimped with a suitable crimp tool. A well crimped Faston connector cannot be removed from the wire by pulling the ends with force. Check this thoroughly! Poor cable connections may result in loss of performance or in damage to the device.

Even with the low EMI produced by the UcD700HG it is advisable to twist the loudspeaker cables and to bundle all the power supply cables (Vee, Vdr, GND and Vcc) to reduce EMI even more.

### Performance Data

Power supply = +/-85V, Load=4Ω, MBW=40kHz, unless otherwise noted

Item	Symbol	Min	Typ	Max	Unit	Notes
Output Power	$P_R$	700	-	-	W	THD=1%
Distortion	THD+N	-	-	0.02	%	20Hz<f<20kHz Pout<P <sub>r</sub> /2
		-	-	0.005	%	20Hz<f<20kHz Pout=1W
DC offset	$V_{DC}$	-	-	1m	V	
Output noise	$U_N$	-	30μ	35μ	V	Unwtd, 20Hz-20kHz
Output Impedance	$Z_{OUT}$	-	-	20m	Ω	f<1kHz
		-	-	150m	Ω	f<20kHz
Power Bandwidth	PBW		20-35k		Hz	
Frequency Response		10	-	50k	Hz	+0/-3dB. All loads
Voltage Gain	$A_V$	25.5	26	26.5	dB	
Supply Ripple Rejection	PSRR		65		dB	Either rail, all frequencies
Efficiency	$\eta$		92		%	Full power
Idle Losses	$P_0$		15		W	+/- 90V rails
Standby Current	$I_{STBY}$		10m		A	
Current Limit	$I_{OUT,P}$		28		A	Stop mode after limiting for 40ms

### Absolute Maximum Ratings

**! Correct operation at these limits is not guaranteed. Operation beyond these limits may result in irreversible damage**

Item	Symbol	Rating	Unit	Notes
Power supply voltage	$V_B$	+/- 100	V	Unit shuts down when either rail exceeds 96V
Driver supply voltage	$V_{DR}$	+15.5	V	Referred to -V <sub>B</sub>
Peak output current	$I_{OUT,P}$		A	Unit current-limits at 28 A
Input voltage	$V_{IN}$	+/-13	V	Either input referred to ground
Air Temperature	$T_{AMB}$	65	°C	
Heat-sink temperature	$T_{SINK}$	90	°C	User to select heat sink to insure this condition under most adverse use case

### Recommended Operating Conditions

Item	Symbol	Min	Typ	Max	Unit	Notes
Power supply voltage	$V_R$	75	90	95	V	
Load impedance	$Z_{LOAD}$	1			Ω	
Source impedance	$Z_{SRC}$			7k	Ω	Differential. Corresponds to 3dB noise increase.
Effective power supply storage capacitance	$C_{SUP}$	10.000 μ			F	Per rail, per attached amplifier. 4Ω load presumed.

### User notes

---

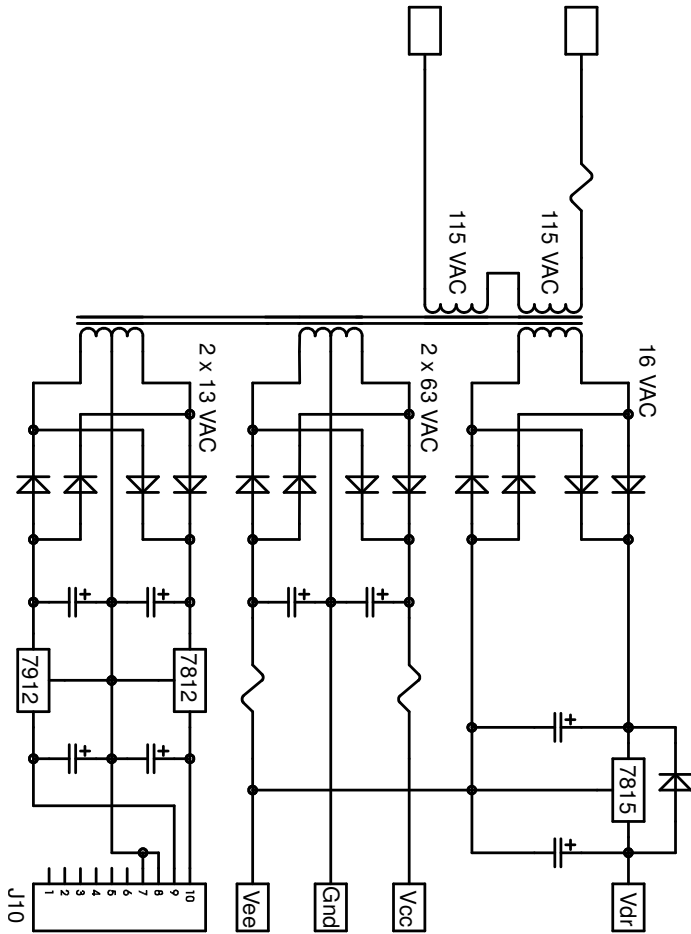

Fig 15. Typical single rectifier power supply.

**NOTE:** The above is a schematic presentation and does not show DC-protection circuitry.

### Typical Performance Graphs

Fig 3. THD vs. Power (1KHz, 4Ω)

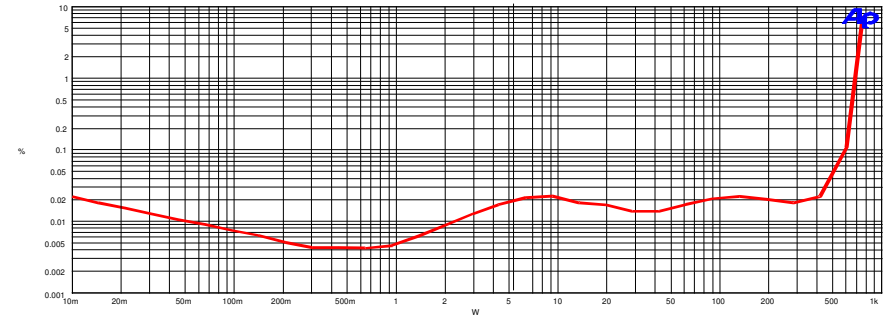

Fig 4. Frequency Response (4Ω, 8Ω and open circuit). From top to bottom: open circuit, 8Ω, 4Ω

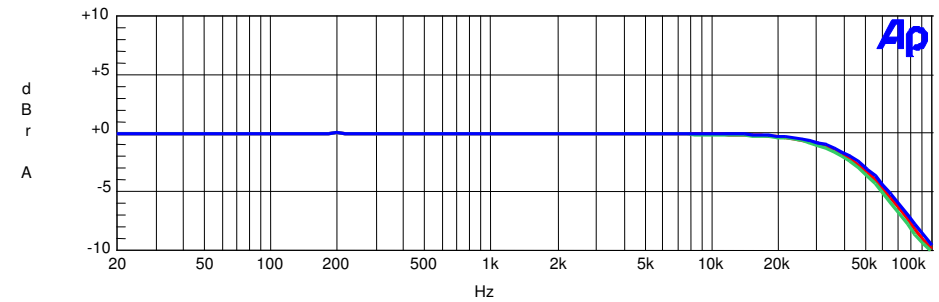
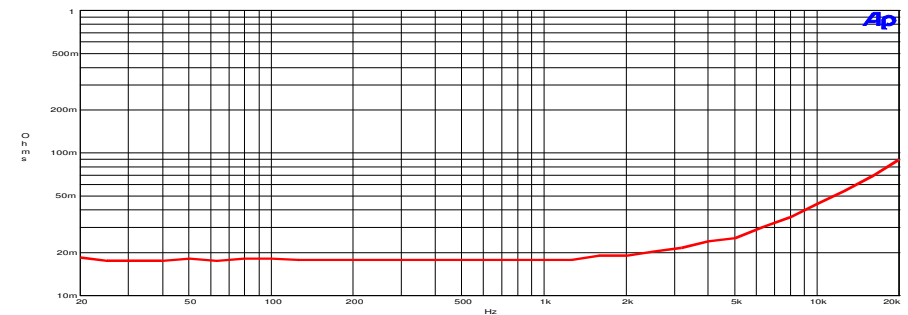

Fig 5. Output Impedance



### Application Information

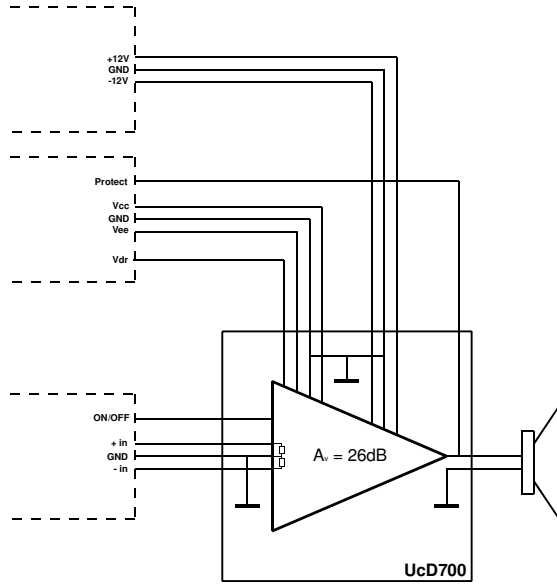

Fig 6. Typical application

### Standby Control

The Standby pin is used to put the amplifier in a low power consumption mode. When this pin is held low the amplifier will be enabled. Only after initial power-up the amplifier will be disabled for 1.5 sec. regardless of the state of the Standby pin. When the UcD700HG is used with the matching UcD700 power supply, this pin will be controlled automatically upon (dis)connecting the mains voltage. When external control has been selected, ON/OFF must be controlled as shown in Fig 7 or Fig 8.

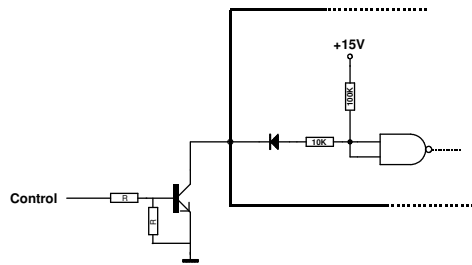

Fig 7. Transistor controlled ON/OFF

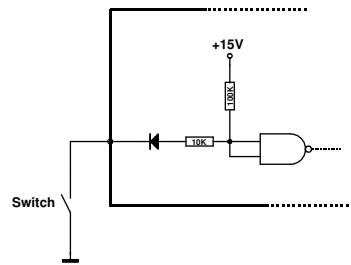

Fig 8. Switch controlled ON/OFF

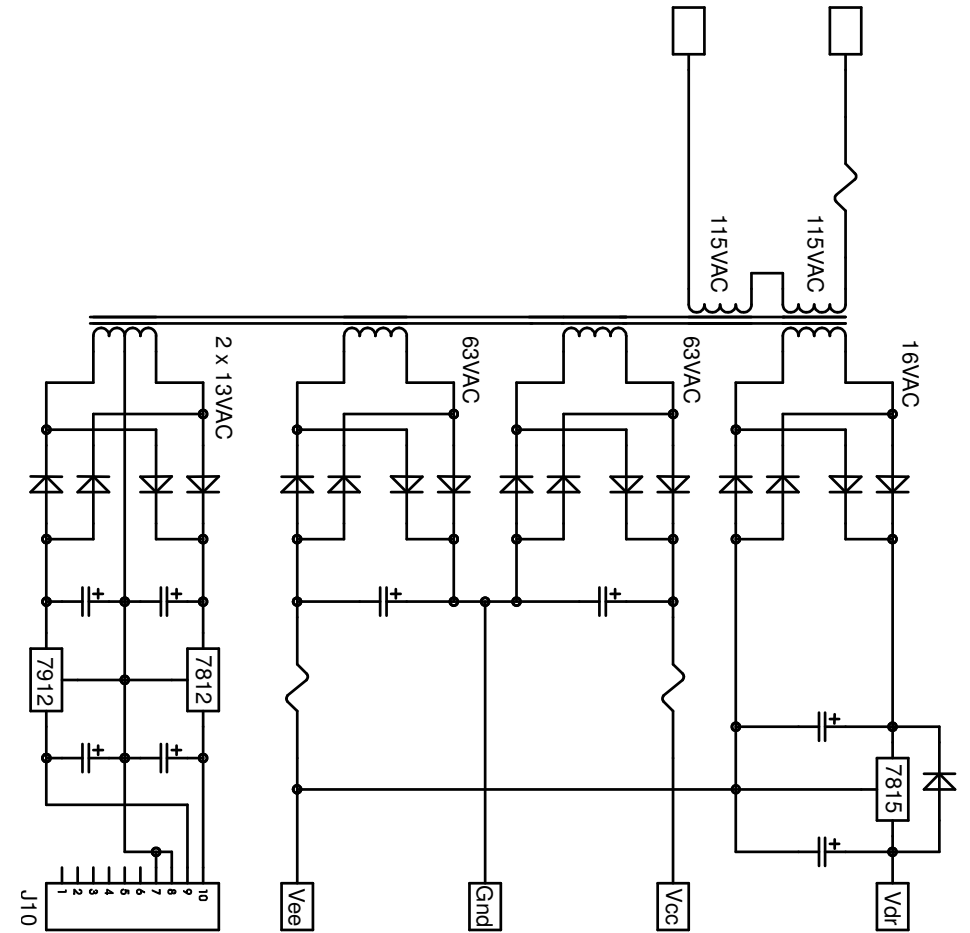

Fig 14. Typical dual rectifier power supply.

**NOTE:** The above is a schematic presentation and does not show DC-protection circuitry.

### Heatsink Considerations

Even with an efficiency of over 90% there is almost 70 Watts to dissipate with 700W continuously output. The UcD700 has no temperature sensing. When in a certain application temperature monitoring is required, it has to be done externally by the customer (The Hypex SoftStart module could be used for this purpose). Since the UcD700 is designed for music only it will never have to deliver 700 Watts continuously. Therefore the heatsink can remain relatively small. Mounting the module on an aluminium backplane (use thermal compound) is sufficient under normal conditions.

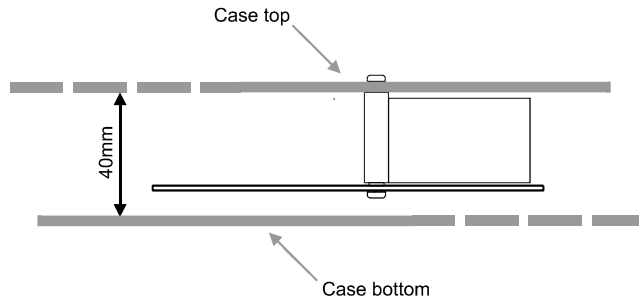

Fig 13. UcD700 1HE implementation

Because of the small dimension of the UcD700 it is relatively easy to implement the module in a 1HE 19" housing with an internal height of only 40mm.

### Input Select

The default settings for input select are based on using the UcD700 with the matching Power Supply: ON/OFF controlled by supply and audio signal must be applied to the 4-pin connector. User selectable options can be made by means of a 0Ω SMD0805 resistor according the table below.

Item Select	R78	R76 / R77	Notes
<b>ON/OFF</b> (4-pin MOLEX® KK®)	not placed	NA	
<b>ON/OFF</b> (10-pin Flatcable header)	placed	NA	Default setting
<b>Input Signal</b> (4-pin MOLEX® KK®)	NA	not placed	Default setting
<b>Input Signal</b> (10-pin Flatcable header)	NA	placed	

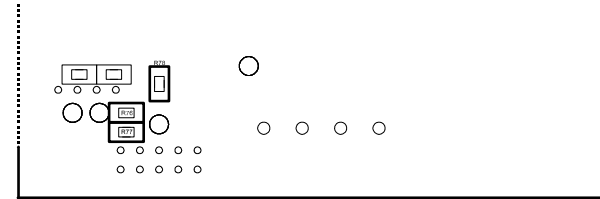

Fig 9. User selectable input (bottom side PCB)

### Adjusting DC offset

The amplifiers DC offset is factory adjusted at <1mV for AC coupling. If the coupling is set to DC, the amplifier may need some readjusting due to DC offset in the amplifier's input buffering. Adjusting is done by turning the potentiometer located on the small PCB.

**! Never change the setting of the potentiometer marked 'TT ADJ'.**

Checking / adjusting DC offset:

- Short circuit the signal inputs to ground.
- Connect a proper voltmeter (mV) to the amplifiers output. (Due to the HF switching residue of the amplifier ( $600\text{mV}_{\text{rms}}$ ) present at the output, some cheaper voltmeters will display an incorrect value).
- Switch the amplifier 'ON' and let the amplifier settle for a couple of minutes.
- Use a suitable screwdriver/trimmer and gently turn the potentiometer left or right until a voltage of <1mV is displayed.
- Switch off the amplifier

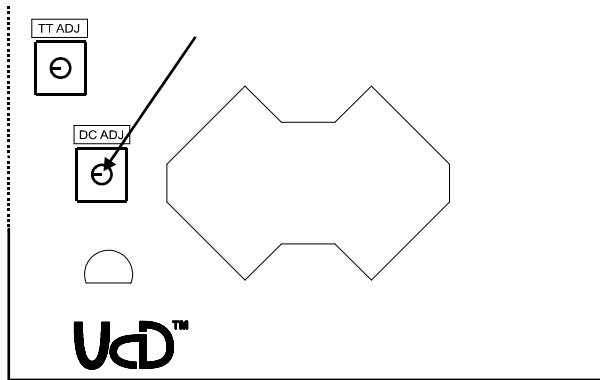

Fig 11. Adjusting DC offset

### Protection

- Output current is limited to  $28\text{A}_{\text{pk}}$ . To prevent overheating in case of a continuous overcurrent condition, the unit will shut down if an overcurrent condition persists for over 40ms. Operation is automatically resumed after 1.5s.
- If the applied supply voltage exceeds a level of 96V (either rail) the unit shuts off until a safe supply voltage is being applied.
- For optimal performance and protection the matching UcD700 power supply should be used to ensure your loudspeakers are fully protected against dangerous DC voltages. This means that in case of an amplifier component failure the supply is switched off until the amplifier is disconnected from the mains for about 3 minutes. DC error is interfaced like shown below.

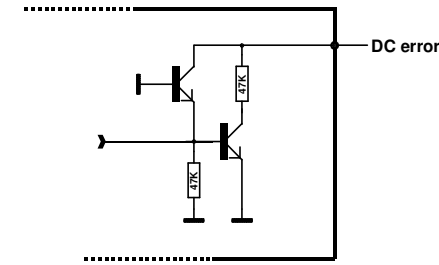

Fig 12. DC error out

**WARNING!** The amplifier has a DC error detection to signal catastrophic failure of the power stage. This is an open collector line. If this line is pulled down, the power supply should shut down and remain latched off until the power is cycled. The Hypex UcD700 power supply board supports this feature.

To fully ensure the protection of your loudspeaker the matching Hypex UcD700 supply is very much recommended.