

energy

## ES 300

700 watt

### Technical Specifications

<b>Component</b>	Subwoofer	
<b>Size</b>	mm	300 (12")
<b>Power Handling (Watt)</b>	peak	700
	continuous program	350
<b>Impedance</b>	Ohm	4
<b>Frequency response</b>	Hz	25-250
<b>Sensitivity</b>	dB/SPL	94
<b>Outer diameter</b>	mm	312
<b>Mounting hole diameter</b>	mm	277
<b>Magnet size</b>	mm	140
<b>Total depth</b>	mm	146
<b>Mounting depth</b>	mm	132
<b>Total driver displacement</b>	lit	1,8
<b>Weight of one component</b>	kg	4,93
<b>Voice coil diameter</b>	mm	60
<b>Magnet</b>	Double magnet, High density ferrite	
<b>Cone</b>	Water-repellent, pressed paper cone	
<b>Xmech*</b>	mm	14,5

### Electro-Acoustic Parameters

<b>D</b>	mm	258
<b>Xmax</b>	mm	9
<b>Re</b>	ohm	2,9
<b>Fs</b>	Hz	28
<b>Le</b>	mH@1kHz	2,66
<b>Le</b>	mH@10kHz	1,17
<b>Vas</b>	lit	89,40
<b>Mms</b>	gr	151,2
<b>Cms</b>	mm/N	0,21
<b>BL</b>	T-m	13,46
<b>Qts</b>		0,38
<b>Qes</b>		0,43
<b>Qms</b>		3,45
<b>Spl (1m/2,83V)</b>	dB	94

\* Xmech maximum mechanic excursion: it indicates the motion range in the speaker linear functioning area, in both ways.



- High thermal dissipation and magnetic permeability plates.
- Big, high power double magnet.
- Pure copper voice coil, wound on Kapton former.
- Back vented hole.
- Butyl rubber gasket for mounting surfaces coupling.
- Butyl rubber protective ring.
- Internally reinforced basket, protected from abrasions by high resistance paint.
- High current, gold-plated terminals.
- Basket and motor are coupled and damped through special epoxy glue.
- Wide-wave, resin-bonded fibre spider.
- High density rubber surround, for mobile voice coil linear, long excursion.
- Water-repellent pressed paper cone.

### Impedance

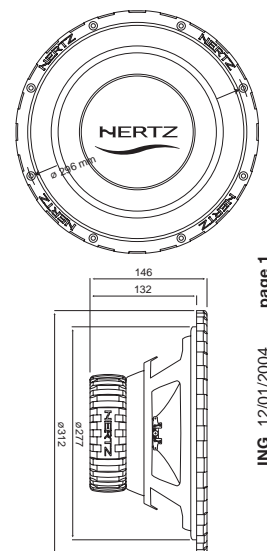
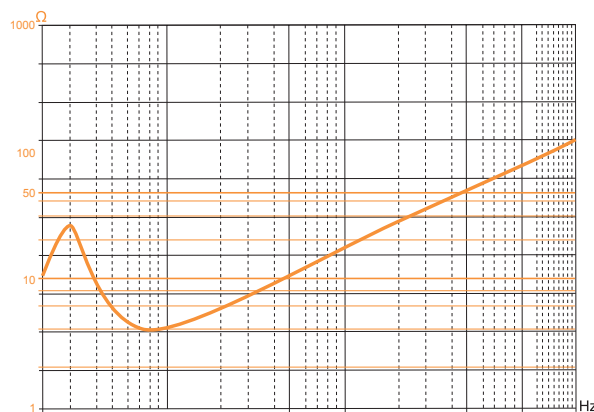

## design es 300

The speaker overall volume must be taken into account when designing a box: if the driver is mounted with its magnet facing the box inner part, add the volume indicated in the Technical Specifications (Total driver displacement) to total volume calculation.  
 The volumes of Reflex, Asymmetric Bandpass and Double Reflex projects include tubes and ports overall dimensions.

### Sealed Box

It is the best compromise between size and performances; it insures powerful bass and good dynamics.

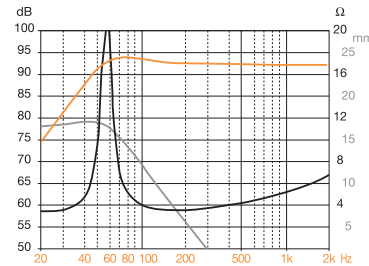
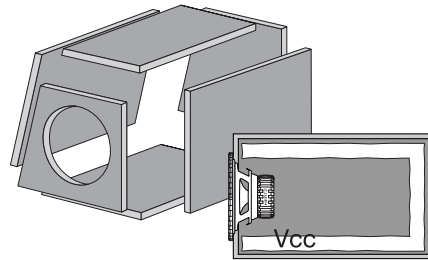

**Sealed Box**  
**Vcc** = 25 Lit  
**Fc** = 50 Hz  
**F-3** = 45 Hz

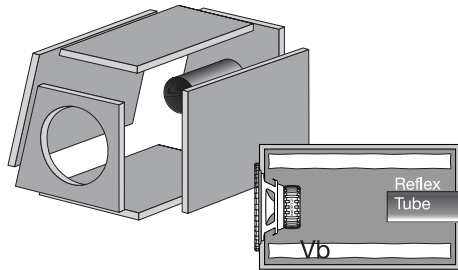

### Reflex Box

Bigger than Sealed Box, it permits to have better power handling and fast, wide sound.

**Reflex Box**  
**Vb** = 34 Lit  
**Fb** = 28 Hz  
**Reflex Tube**  
**Ø** = 62 mm  
**L** = 270 mm

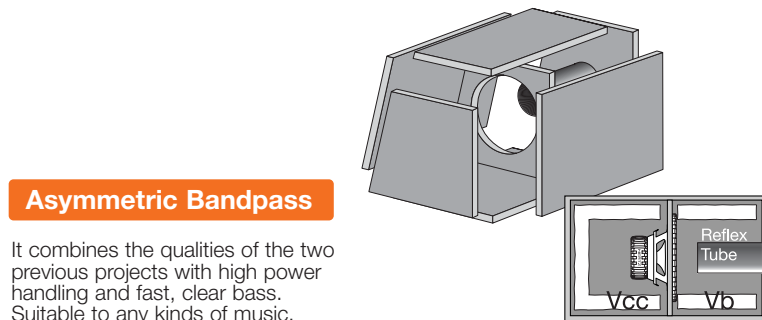
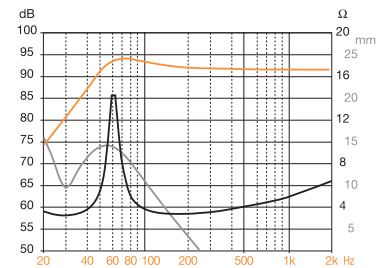

### Asymmetric Bandpass

It combines the qualities of the two previous projects with high power handling and fast, clear bass. Suitable to any kinds of music.

**Asymmetric Bandpass**  
**Vcc** = 16 Lit  
**Vb** = 25 Lit  
**Fb** = 65 Hz  
**Reflex Tube**  
**Ø** = 100 mm  
**L** = 145 mm

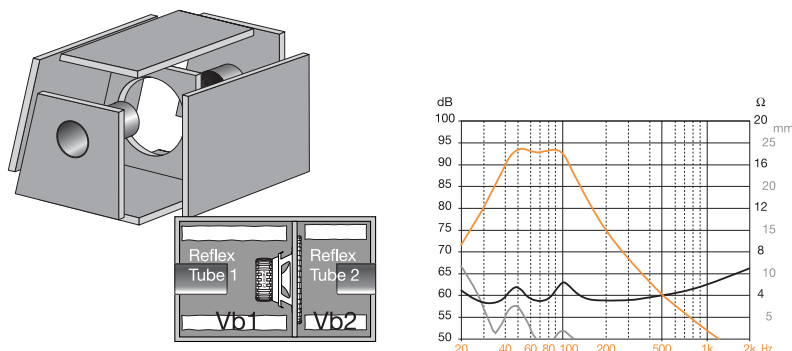
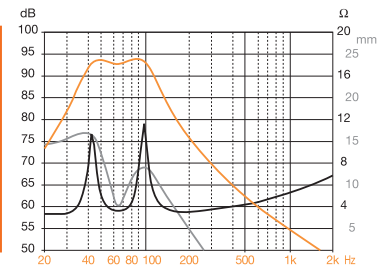

**Double Reflex**  
**Vb1** = 20 Lit    **Vb2** = 30 Lit  
**Fb1** = 76 Hz    **Fb2** = 35 Hz  
**Reflex Tube 1**    **Reflex Tube 2**  
**Ø** = 100 mm    **Ø** = 82 mm  
**L** = 145 mm    **L** = 310 mm

### Double Reflex

It is more difficult to build and bigger. Perfect for techno and disco music.