

- 1" voice coil Kapton former
- Balanced neodymium magnet circuit
- Ventilated voice coil to reduce power compression
- 88.7 dB sensitivity



Specifications	
Nominal Diameter	88mm (3,5")
Nominal Impedance	8Ω
Rated Power AES ⁽¹⁾	30W
Continuous Program Power ⁽²⁾	60W
Sensitivity @ 1W/1m ⁽³⁾	88.7dB
Voice Coil Diameter	25mm (1")
Voice Coil Winding Depth	6mm
Magnetic Gap Depth	4mm
Flux Density	1.20T
Magnet Weight	42g
Net Weight	0.2kg

Thiele & Small Parameters ⁽⁴⁾			
Re	5.10Ω	Fs	130.0Hz
Qms	4.68	Qes	0.69
Qts	0.60	Mms	3.3g
Cms	454μm/N	Bxl	4.47Tm
Vas	1.0l	Sd	38.5cm ²
X max ⁽⁵⁾	+/-1.5mm	X var ⁽⁶⁾	+/-3.1mm
η ₀	0.28%	Le (1kHz)	0.12mH

Constructive Characteristics	
Magnet	: Neodymium
Basket Material	: Nylon Fiberglass Doped
Voice Coil Winding Material	: Copper
Voice Coil Former Material	: Kapton
Cone Material	: Paper
Cone Treatment	: No
Surround Material	: Rubber
Dust Dome Material	: Treated Cloth

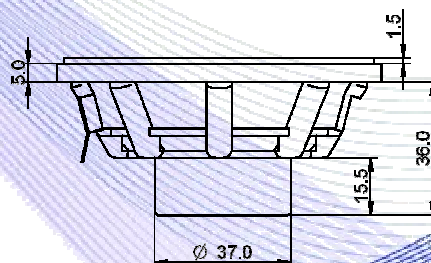
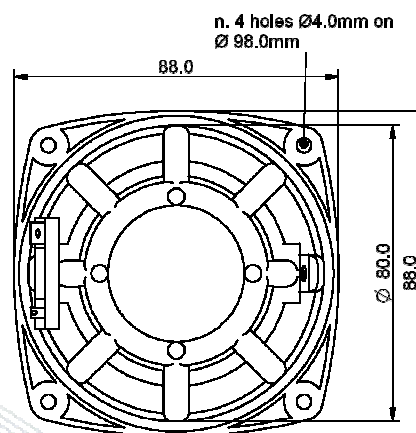

Frequency Response on IEC Baffle (DIN 45575) @ 1W,1m – Free Air Impedance

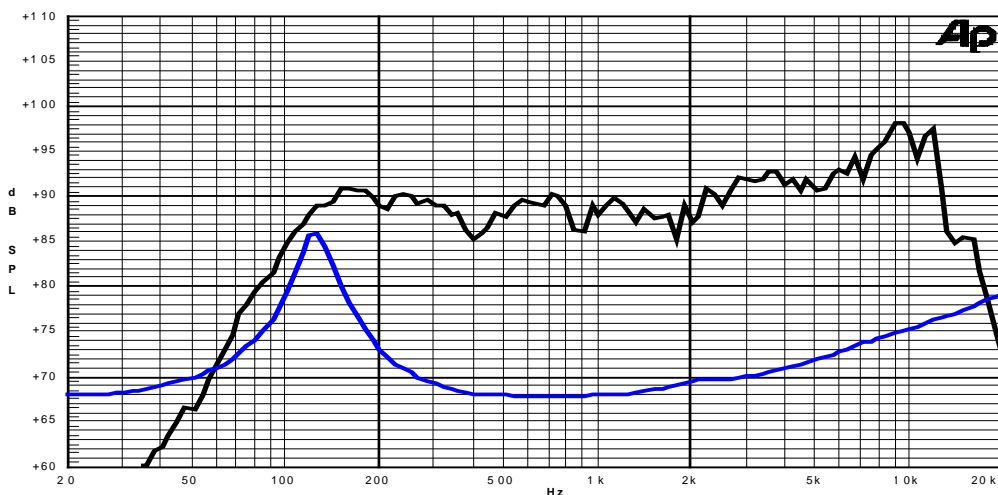

- Note:
- 1 : Rated Power measured with 2 hours test with pink noise signal, 6dB crest factor, loudspeaker mounted on enclosure
 - 2: Power on Continuous Program is defined as 3 dB greater than the Rated Power
 - 3: Calculated by Thiele & Small parameters
 - 4: Thiele & Small parameters measured with laser system without preconditioning test
 - 5: Measured with respect to a THD of 10% using a parameter-based method
 - 6: Value corresponding to a decay of the Force Factor, or Compliance, or both, equal to the 50% of the small signal value.
 - 7: Drawing dimensions: mm
 - 8: The notch around 400Hz on the frequency response is typical of the measurement on IEC baffle