

SPECIFICATIONS

FR040WA01/02 1½" neodymium, alu-cone fullranges, 4/8 ohm

The 1½" transducers FR040WA01 (4 ohm) and FR040WA02 (8 ohm) were designed especially for high quality multimedia and lifestyle speakers, and for personal audio products, where sound reproduction without compromises is required. Will work well as a midrange/treble transducer in small speaker products in combination with for instance a small subwoofer unit.

December 2017: **IMPORTANT !** Dimensions (overall depth) have been updated. Please check outline drawing below

FEATURES

- True full-range design with on-axis output to beyond 20kHz
- Dual neodymium magnet structure for high efficiency and almost ideal magnetically shielding
- Copper cap on center pole to reduce voice coil inductance and to minimize variations in voice coil inductance as a function of voice coil position
- Black anodized alu cone for better heat transfer
- Optimized off-axis response
- Vented polymer chassis for lower air flow speed reducing audible distortion
- Vented voice coil former for reduced distortion and compression
- Heavy-duty black fiber glass voice coil bobbin to reduce mechanical losses resulting in better dynamic performance and low-level details
- Large motor with 16 mm voice coil diameter for better control and power handling
- Low-loss suspension (high Qm) for better reproduction of details and dynamics
- Black motor parts for better heat transfer to the surrounding air
- Conex spider for better durability under extreme conditions
- Gold plated terminals to ensure long-term trouble free connection



NOMINAL SPECIFICATIONS

Notes	Parameter	FR040WA01		FR040WA02		Unit
		Before burn-in	After burn-in	Before burn-in	After burn-in	
	Nominal size	1½		1½		[inch.]
	Nominal impedance	4		8		[ohm]
	Recommended max. upper frequency limit	full range		full range		[kHz]
1, 4	Sensitivity, 2.83V/1m	84		81		[dB]
2, 4	Power handling, short term, IEC 268-5, no additional filtering	35		35		[W]
2, 4	Power handling, long term, IEC 268-5, no additional filtering	15		15		[W]
2, 4	Power handling, continuous, IEC 268-5, no additional filtering	3		3		[W]
	Effective radiating area, S _d	7.8		7.8		[cm ²]
3, 4, 6	Resonance frequency (free air, no baffle), F _s	233		239		[Hz]
	Moving mass, incl. air (free air, no baffle), M _{MS}	0.63		0.60		[g]
3, 4	Force factor, B _{xl}	1.67		2.0		[N/A]
3, 4, 6	Suspension compliance, C _{MS}	0.74		0.74		[mm/N]
3, 4, 6	Equivalent air volume, V _{AS}	0.064		0.064		[lit.]
3, 4, 6	Mechanical resistance, R _{MS}	0.096		0.096		[Ns/m]
3, 4, 6	Mechanical Q, Q _{MS}	9.6		9.4		[-]
3, 4, 6	Electrical Q, Q _{ES}	0.99		1.42		[-]
3, 4, 6	Total Q, Q _{TS}	0.90		1.23		[-]
4	Voice coil resistance, R _{DC}	3.0		6.3		[ohm]
5	Voice coil inductance, L _e (measured at 10 kHz)	0.053		0.081		[mH]
	Voice coil inside diameter	16		16		[mm]
	Voice coil winding height	3		3		[mm]
	Air gap height	2		2		[mm]
	Theoretical linear motor stroke, X _{max}	±0.5		±0.5		[mm]
	Magnet weight					[g]
	Total unit net weight excl. packaging	0.037		0.037		[kg]
3, 4, 5	K _{RM}	0.016		0.018		[mohm]
3, 4, 5	E _{RM}	0.98		1.01		[-]
3, 4, 5	K _{XM}	0.66		1.15		[mH]
3, 4, 5	E _{XM}	0.73		0.71		[-]

Note 1 Measured in infinite baffle.

Note 2 Tested in free air (no cabinet).

Note 3 Measured using a semi-constant current source, nominal level 2 mA.

Note 4 Measured at 25 deg. C

Note 5 It is generally a rough simplification to assume that loudspeaker transducer voice coils exhibit the characteristics of an inductor. Instead it is a far more accurate approach to use the more advanced model often referred to as the "Wright empirical model", also used in LEAP-4 as the TSL model (www.linearx.com), involving parameters K_{RM}, E_{RM}, K_{XM}, and E_{XM}. This more accurate transducer model is described in a technical paper [here at our web site](#).

Note 6 After burn-in specifications are measured 12 hours after exiting the transducer by a 20 Hz sine wave for 2 hours at level 2.83/4.0 V_{RMS} (4/8 ohm version). The unit is not burned in before shipping.

SPECIFICATIONS

FR040WA01/02 1½" neodymium, alu-cone fullranges, 4/8 ohm

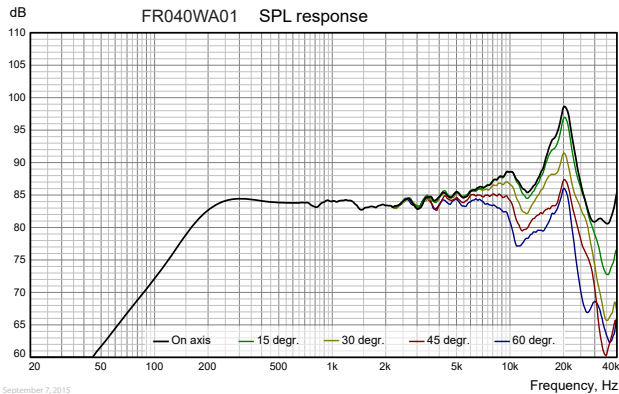

Download FR040WA01 SPL response as .txt file

Measuring conditions, SPL

Driver mounting: Flush in infinite baffle, back side open (no cabinet)
 Microphone distance: 1.0 m
 Input signal: 2.83 VRMS stepped sine wave
 Smoothing: 1/6 oct.

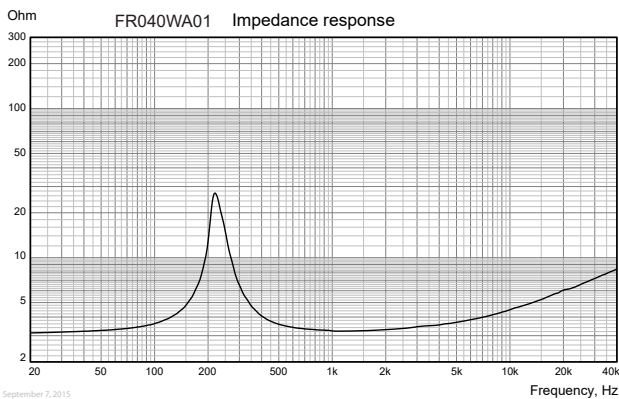

Download FR040WA01 impedance response as .txt file

Measuring conditions, impedance

Driver mounting: Free air, no baffle, back side open (no cabinet)
 Input signal: Stepped sine wave, semi-current-drive, nominal current 2 mA
 Smoothing: None

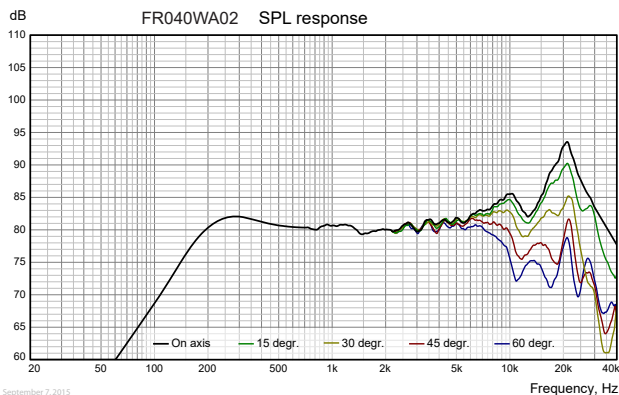

Download FR040WA02 SPL response as .txt file

Measuring conditions, SPL

Driver mounting: Flush in infinite baffle, back side open (no cabinet)
 Microphone distance: 1.0 m
 Input signal: 2.83 VRMS stepped sine wave
 Smoothing: 1/6 oct.

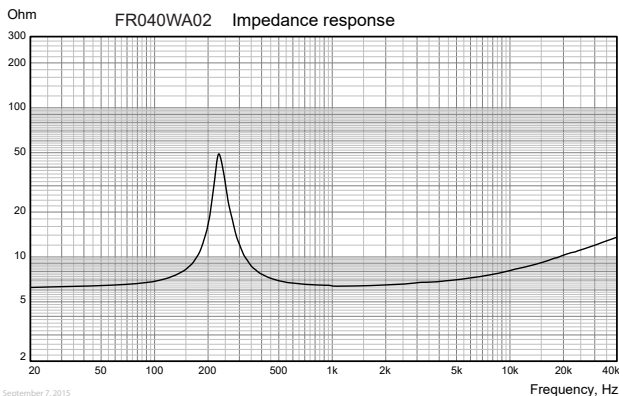

Download FR040WA02 impedance response as .txt file

Measuring conditions, impedance

Driver mounting: Free air, no baffle, back side open (no cabinet)
 Input signal: Stepped sine wave, semi-current-drive, nominal current 2 mA
 Smoothing: None

SPECIFICATIONS



FR040WA01/02 1½" neodymium, alu-cone fullranges, 4/8 ohm

HARMONIC DISTORTION

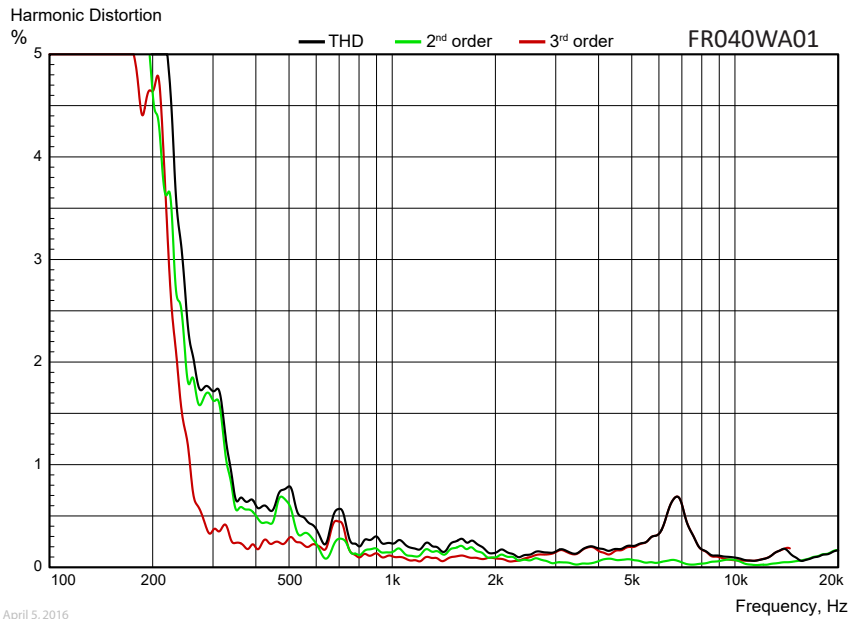

April 5, 2016

Measuring conditions, Harmonic Distortion

Driver mounting: In sealed, heavily stuffed enclosure, internal volume 0.30 lit., baffle dimensions 79 mm x 79 mm

Microphone distance: 0.5 m

Input signal: Stepped sine wave, 1.10 VRMS (FR040WA01) / 1.55 VRMS (FR040WA02)

Smoothing: 1/6 oct.

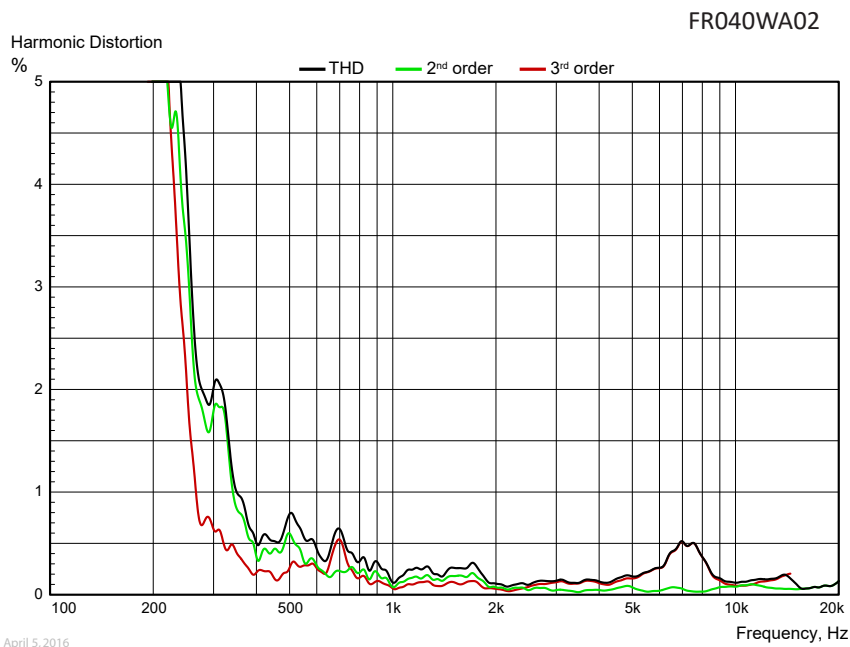

April 5, 2016

SPECIFICATIONS

FR040WA01/02 1½" neodymium, alu-cone fullranges, 4/8 ohm

OUTLINE DRAWING (nominal dimensions)

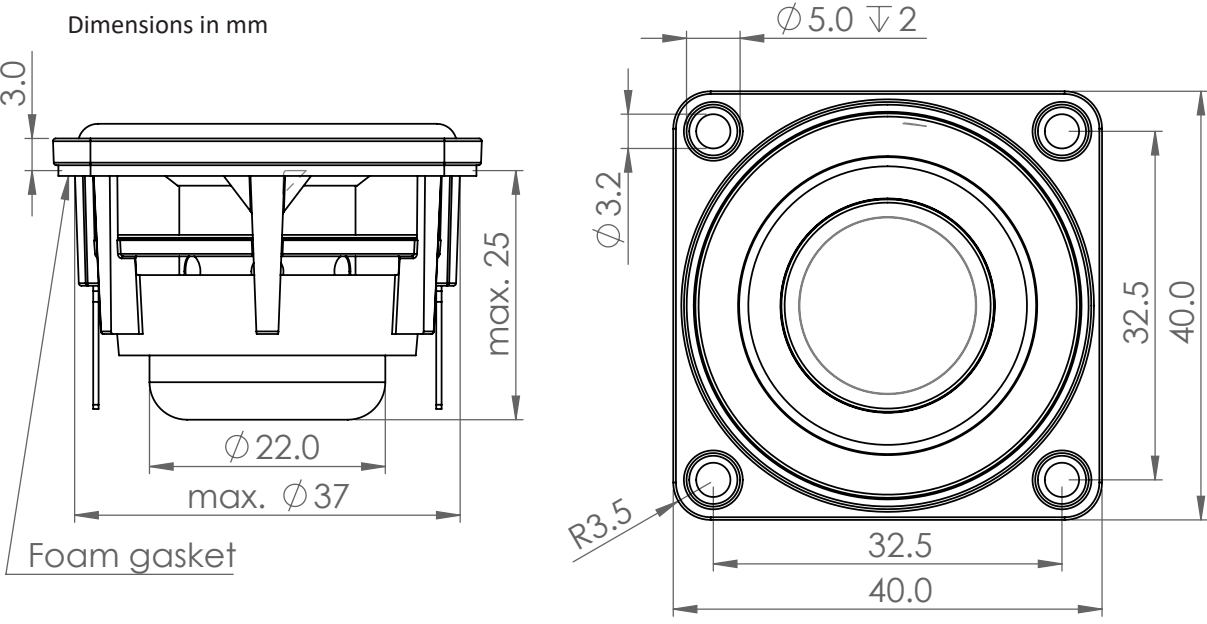

CONNECTIONS

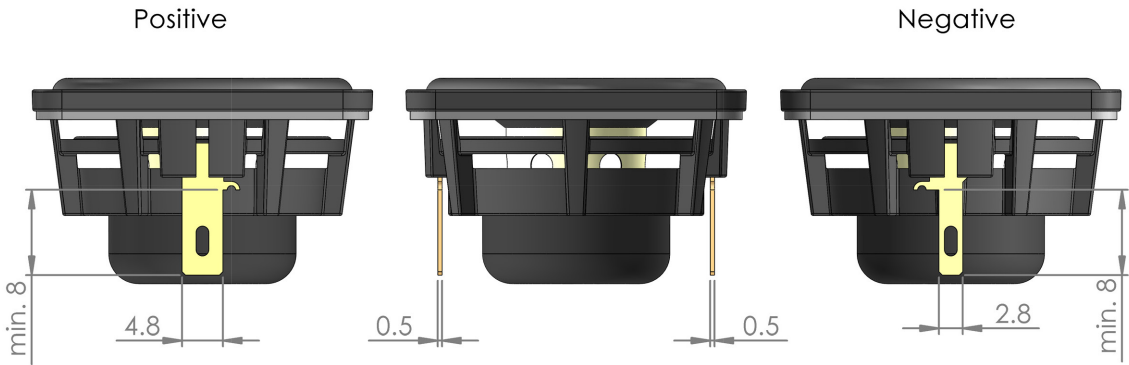

PACKAGING AND ORDERING INFORMATION

Part no. FR040WA01-01	4 ohm version, packed in pairs
Part no. FR040WA01-02	4 ohm version, packed in bulk (industrial) packaging
Part no. FR040WA02-01	8 ohm version, packed in pairs
Part no. FR040WA02-02	8 ohm version, packed in bulk (industrial) packaging

Latest update: April 13, 2018