

- Smooth sound bass guitar loudspeaker
- 2.5" voice coil fiberglass former
- Cone waterproof treatment
- Ventilated magnet circuit to reduce power compression
- Neodymium magnet circuit
- 95.0 dB sensitivity

Specifications	
Nominal Diameter	268mm (10")
Nominal Impedance	8Ω
Rated Power AES <sup>(1)</sup>	250W
Continuous Program Power <sup>(2)</sup>	500W
Sensitivity @ 1W/1m <sup>(3)</sup>	95.0dB
Voice Coil Diameter	65mm (2.5")
Voice Coil Winding Depth	18mm
Magnetic Gap Depth	8mm
Flux Density	1.14T
Magnet Weight	220g
Net Weight	2.2kg

Thiele & Small Parameters <sup>(4)</sup>			
Re	5.10Ω	Fs	58.0Hz
Qms	6.45	Qes	0.47
Qts	0.43	Mms	41.9g
Cms	180μm/N	Bxl	12.94Tm
Vas	30.9l	Sd	346.3cm <sup>2</sup>
X max <sup>(5)</sup>	+/-5.0mm	X var <sup>(6)</sup>	+/-7.4mm
η <sub>0</sub>	1.22%	Le (1kHz)	0.84mH

Constructive Characteristics	
Magnet	: Neodymium
Basket Material	: Aluminium Die-Cast
Voice Coil Winding Material	: Copper
Voice Coil Former Material	: Fiberglass
Cone Material	: Paper
Cone Treatment	: Surface Waterproof Treatment
Surround Material	: Treated Cloth
Dust Dome Material	: Solid Paper

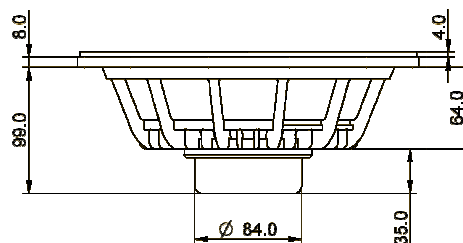
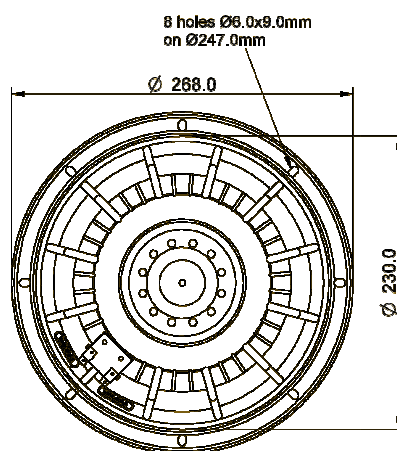

Frequency Response on 35 Litres Vented Box @ 1W, 0.5m, normalized to SPL 1m  
Free Air Impedance

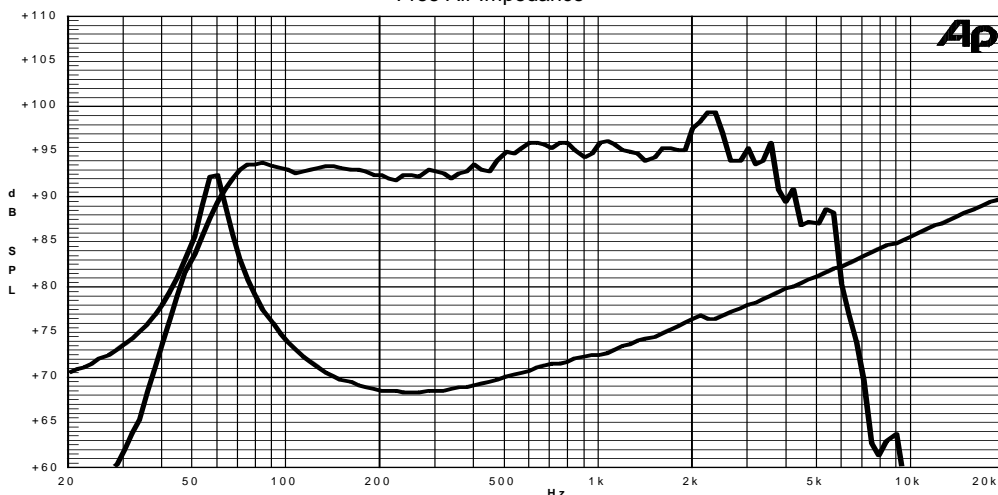

Note:

- 1 : Rated Power measured with 2 hours test with pink noise signal, 6dB crest factor, loudspeaker mounted on enclosure
- 2: Power on Continuous Program is defined as 3 dB greater than the Rated Power
- 3: Calculated by Thiele & Small parameters
- 4: Thiele & Small parameters measured with laser system without preconditioning test
- 5: Measured with respect to a THD of 10% using a parameter-based method
- 6: Value corresponding to a decay of the Force Factor, or Compliance, or both, equal to the 50% of the small signal value.
- 7: Drawing dimensions: mm